

Pioneering for You

Wilo efficient solutions for water supply

Wilo-MHiKE/PBI-L

Home booster system



**“Perfectly
coordinating
performance
and efficiency,**

**that’s what I call
Pioneering for You.”**

Dr. Franka Schneider, Research Engineer Fluid Mechanics
WILO SE



Our goal is your efficiency

Your expert for building services.

We optimise our products for you

With more than 140 years of experience and the know-how of one of the world's leading pump manufacturers, we are your ideal partner for high-efficiency heating, cooling, air-conditioning, water supply and sewage disposal for commercial properties. Because we know what we are doing, and we understand your concerns as a planner. Our goal therefore is to make your daily work as easy, pleasant and successful as possible.

1 Ever more economical

Our pumps become ever more economical. Our developments meet high efficiency standards all over the world. This saves energy and gives you security for the future.

3 Ever quieter

Our pumps become ever quieter, because we analyse their operating noises in an acoustic laboratory using cutting-edge methods and take targeted action to minimise these noises for your customers.

For this reason, we develop and optimise our pumps and systems in direct communication with all those involved, i.e., with planners, installers and operators. The result are products that are not only highly efficient and future-proof but also easy to install and operate. In addition to our extensive range of products, we also offer numerous services and solutions to make your planning even more productive. This is what we mean by Pioneering for You.

2 Ever more intelligent

With intelligent control software, our pumps become ever better at meeting the changing requirements during operation. This increases the flexibility and efficiency of use for your customers.

4 Ever more durable

We examine our pumps in advance in extensive computer simulations and laboratory and field tests to ensure high quality and reliability right from the start. The result are products that ensure high operational reliability over the long term.



Wilo-MHiKE/PBI-L

Home booster system – Excellent Energy Saving



1 Inverter control multi system

Able to set various operation mode

2 Anti rust

All STS & Plastic material

3 Various pump protection function

Dry running protection, Max pressure setting function

4 Reflect environment condition for user

Friction loss compensation, Minimum frequency setting function

Control and protection function

Function	MHiKE/PBI-L	MHiKE-D/PBI-LD	MHiKE-W/T
Operation at fixed pressure set	0	0	0
Unusual excessive pressurizing protection	0	0	0
Automatic restart after fault	0	0	0
Automatic restart after blackout	0	0	0
Dry running protection	0	0	0
Auto/manual operation	0	0	0
Over/under voltage protection	0	0	0
Warm-up operation mode	-	0	0
Alternative operation mode	-	0	0
Automatic back up (when in trouble)	-	0	0
Friction loss compensation	-	0	0
Max pressure setting function	-	-	0
Max/minimum frequency setting, sequential operation	-	-	0

Specification

Model	Power(kW)	Power source	Inverter output(kW)	Operation pressure (kgf/cm ²)	Rated Capacity	Pipe dia(mm)		Max.fluid Temperature (°C)					
						Suc.	Dis.						
MHiKE-203MA/PBI-L203MA	0.75	220V 60Hz Single phase	0.75/1.1	2	70 ℓ/min	25	25	80					
PBI-L303MA			1.1		60 ℓ/min			35					
MHiKE-402MA/PBI-L402MA			0.75/1.1		70 ℓ/min			80					
MHiKE-205MA/PBI-L205MA	1.1		1.5/1.1	4	70 ℓ/min	25		80					
PBI-L304MA			1.1		50 ℓ/min			35					
MHiKE-403MA/PBI-L403MA			1.5/1.1		2			130 ℓ/min	80				
PBI-L603MA	1.5		1.1	2	100 ℓ/min	32	32	35					
PBI-L991MA			1.85	1.5	200 ℓ/min								
MHiKE-404MA/PBI-L404MA			1.5	4	90 ℓ/min				32	25			
MHiKE-802MA/PBI-L802MA	1.85		380V 60Hz Three phases	1.5/1.85	2	180 ℓ/min	40	32	80				
MHiKE-405MA/PBI-L405MA				2.2/1.85		4				130 ℓ/min	32	25	
MHiKE-803MA/PBI-L803MA				2		220 ℓ/min				40	32		
PBI-LD402MA	0.75X2	1.1X2		2	3.5	180 ℓ/min	50	50					
PBI-LD403MA										2	180 ℓ/min	50	50
MHiKE-D404MA/PBI-LD404MA										1.5X2	4	180 ℓ/min	50
MHiKE-D802MA/PBI-LD802MA	1.85X2	1.5X2/1.85X2		2	340 ℓ/min	65	65						
MHiKE-D405MA/PBI-LD405MA		2.2X2/1.85X2			4			220 ℓ/min		50	50		
MHiKE-D803MA/PBI-LD803MA		2			380 ℓ/min			65		65			
MHiKE-406UA	2.2	380V 60Hz Three phases		3.0	7	110 ℓ/min	32	25					
MHiKE-804UA	2.5					4				200 ℓ/min	40	32	
MHiKE-W406UA	2.2X2					2.2				7	180 ℓ/min	50	50
MHiKE-W804UA	2.5X2		3.0	5	360 ℓ/min	65	65						
MHiKE-W805UA	3.0X2		4.0	6	400 ℓ/min	65	65						
MHiKE-T406UA	2.2X3		2.2	7	270 ℓ/min	65	65						
MHiKE-T804UA	2.5X3		3.0	5	540 ℓ/min	80	80						
MHiKE-T805UA	3.0X3		4.0	6	550 ℓ/min	80	80						

* Rated capacity is based on operation pressure.

* The suction head of PBI-L303/304/603/991MA (self priming model) is 6m.

* ' / ' at the inverter output distinguishes between the inverter output of MHiKE and PBI-L in the order named. ex) MHiKE-203MA: 0.75 kW, PBI-L203MA: 1.1 kW

Model selection table

1. Downward water supply (roof-top type)

Expected pressure (2Kgf/cm²)

Number of house	6	8	10	20	30	40	50	60	80	100	120	140	160	180	200	250	
Capa.	(ℓ/min)	76	84	89	142	186	225	262	296	358	416	470	521	570	617	662	769
	(m ³ /hr)	4.6	5.0	5.3	8.5	11.2	13.5	15.7	17.8	21.5	25.0	28.2	31.3	34.2	37.0	39.7	46.1
Model description	402	402	402	802/ LD402	803/ LD403	D802	D802	D802	D802	W804	W804	W804	T804	T804	T804	T804	

2. Upward water supply

* The meaning of Apartment and accommodation is the number of house and rooms.

20th floor (82m)	W406	W406	W406	T406	T406												
19th floor (78m)	W406	W406	W406	T406	T406	T406											
18th floor (75m)	W406	W406	W406	T406	T406	T406	T406										
17th floor (72m)	W406	W406	W406	W406	T406	T406	T406										
16th floor (68m)	D405	W406	W406	W406	W406	T406	T406	T406	T805	T805							
15th floor (65m)	D405	D405	W406	W406	W406	W805	W805	W805	T805	T805							
14th floor (62m)	D405	D405	W406	W406	W406	W805	W805	W805	T805	T805	T805						
13th floor (58m)	D405	D405	D405	W406	W406	W406	W805	W805	W805	T805	T805	T805					
12th floor (55m)	405	D405	D405	W406	W406	W406	W804	W805	W805	T804	T805	T805	T805				
11th floor (52m)	405	405	D405	D405	W406	W406	W804	W804	W805	W805	T804	T805	T805	T805			
10th floor (49m)	405	405	405	D405	W406	W406	W804	W804	W804	W805	T804	T804	T805	T805			
9th floor (45m)	404	405	405	D405	D405	W406	W804	W804	W804	W805	T804	T804	T804	T805	T805		
8th floor (42m)	404	405	405	D405	D405	W406	W804	W804	W804	W804	W805	T804	T804	T804	T805		
7th floor (39m)	404	404	405	D404	D405	D405	W804	W804	W804	W804	W805	T804	T804	T804	T804	T805	
6th floor (35m)	404	404	404	D404	D405	D405	W804	W804	W804	W804	W805	T804	T804	T804	T804	T805	
5th floor (32m)	403	403	404	D404	D404	D405	D803	W804	W804	W804	W804	T804	T804	T804	T804	T805	
4th floor (29m)	403	403	404	803/LD403	D404	D405	D803	D803	W804	W804	W804	T804	T804	T804	T804	T805	
3rd floor (25m)	403	403	403	803/LD403	D404	D404	D803	D803	D803	W804	W804	W804	T804	T804	T804	T804	
2nd floor (22m)	403	403	403	803/LD403	803/LD403	D404	D803	D803	D803	W804	W804	W804	T804	T804	T804	T804	
1st floor (19m)	203	402	403	803/LD403	803/LD403	D404	D803	D803	D803	W804	W804	W804	T804	T804	T804	T804	
Apartment	6	8	10	20	30	40	50	60	80	100	120	140	160	180	200	250	
Accommodation				15	20	30	40	60	90	120	150	170	200	220	250	300	
Capacity(lpm)	76	84	89	142	186	225	262	296	358	416	470	521	570	617	662	769	
Capacity(m ³ /h)	5	5	5	9	11	14	16	18	21	25	28	31	34	37	40	46	

MHiKE / PBI-L Series

High efficiency pump (Excellent pressure control in real time)



MHiKE / PBI-L Series

- Excellent energy saving (max 80% of saving energy with VFD)
- Various pump protection functions (excellent protection functions always work)
- Handy installation and easy maintenance (by re-starting automatically when the cause of error is solved)
- Excellent design and light weight (low noise & vibration)

Application

- Water supply and Pressure boosting
- Residential areas, motels, holiday houses, etc
- Small sprinkler, water management facility which requires a fixed pressure
- Fire extinguisher pump, industrial circulating system
- Boiler water supply, coolant system, etc

Outline dimension

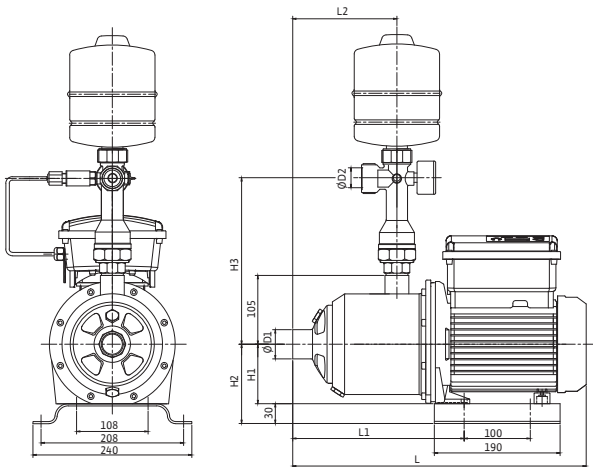

Model	Dimensions(mm)								
	H	H ₁	H ₂	H ₃	L	L ₁	L ₂	D ₁	D ₂
MHiKE-203MA /PBI-L203MA	580	90	120	435	360	204	109.5	25	25
PBI-L303MA	580	90	120	435	425	252	157.5	25	25
MHiKE-402MA /PBI-L402MA	580	90	120	435	360	204	109.5	32	25
MHiKE-205MA /PBI-L205MA	580	90	120	435	425	252	157.5	25	25
PBI-L304MA	580	90	120	435	425	252	157.5	25	25
MHiKE-403MA /PBI-L403MA	580	90	120	435	380	204	109.5	32	25
PBI-L603MA	580	90	120	435	425	252	157.5	32	25
PBI-L991MA	665	-	200	445	450	145	-	40	32
MHiKE-404MA /PBI-L404MA	580	90	120	435	425	252	157.5	32	25
MHiKE-802MA /PBI-L802MA	610	90	120	465	390	216	121.5	40	32
MHiKE-405MA /PBI-L405MA	580	90	120	435	425	252	157.5	32	25
MHiKE-803MA /PBI-L803MA	610	90	120	465	390	216	121.5	40	32
MHiKE-406UA	580	100	104	465	483.8	276	181.5	32	25
MHiKE-804UA	610	100	104	465	483.8	276	181.5	40	32

Performance curve

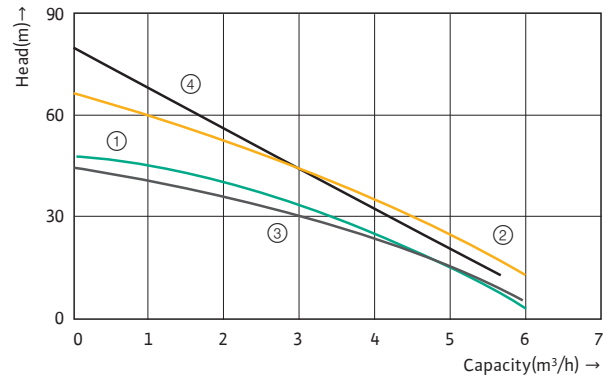

- ① MHiKE-203MA/PBI-L203MA ② MHiKE-205MA/PBI-L205MA
③ PBI-L303MA ④ PBI-L304MA

*PBI-L303/304MA is based suction 0.5m

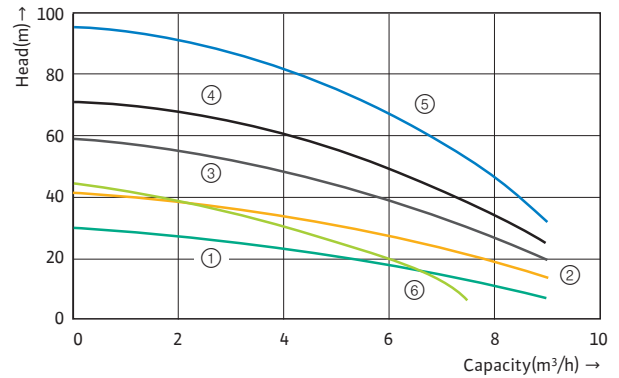

- ① MHiKE-402MA/PBI-L402MA ② MHiKE-403MA/PBI-L403MA
③ MHiKE-404MA/PBI-L404MA ④ MHiKE-405MA/PBI-L405MA
⑤ MHiKE-406UA ⑥ PBI-L603MA

*PBI-L603MA is based suction 0.5m

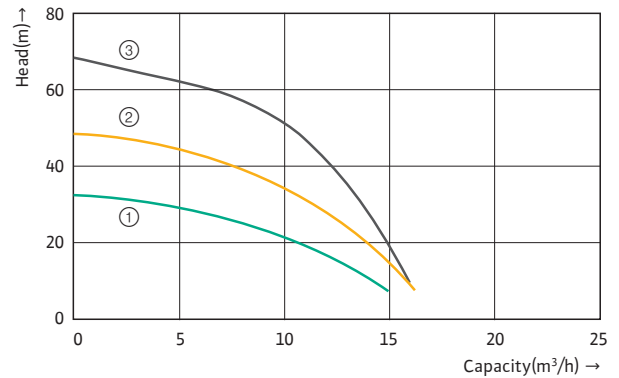

- ① MHiKE-802MA/PBI-L802MA ② MHiKE-803MA/PBI-L803MA
③ MHiKE-804UA

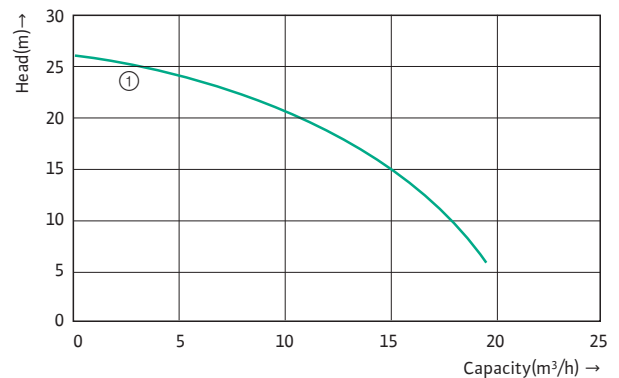

- ① PBI-L991MA

*PBI-L991MA is based suction 0.5m

MHiKE-D / PBI-LD Series

High efficiency pump (Low noise & Energy saving)

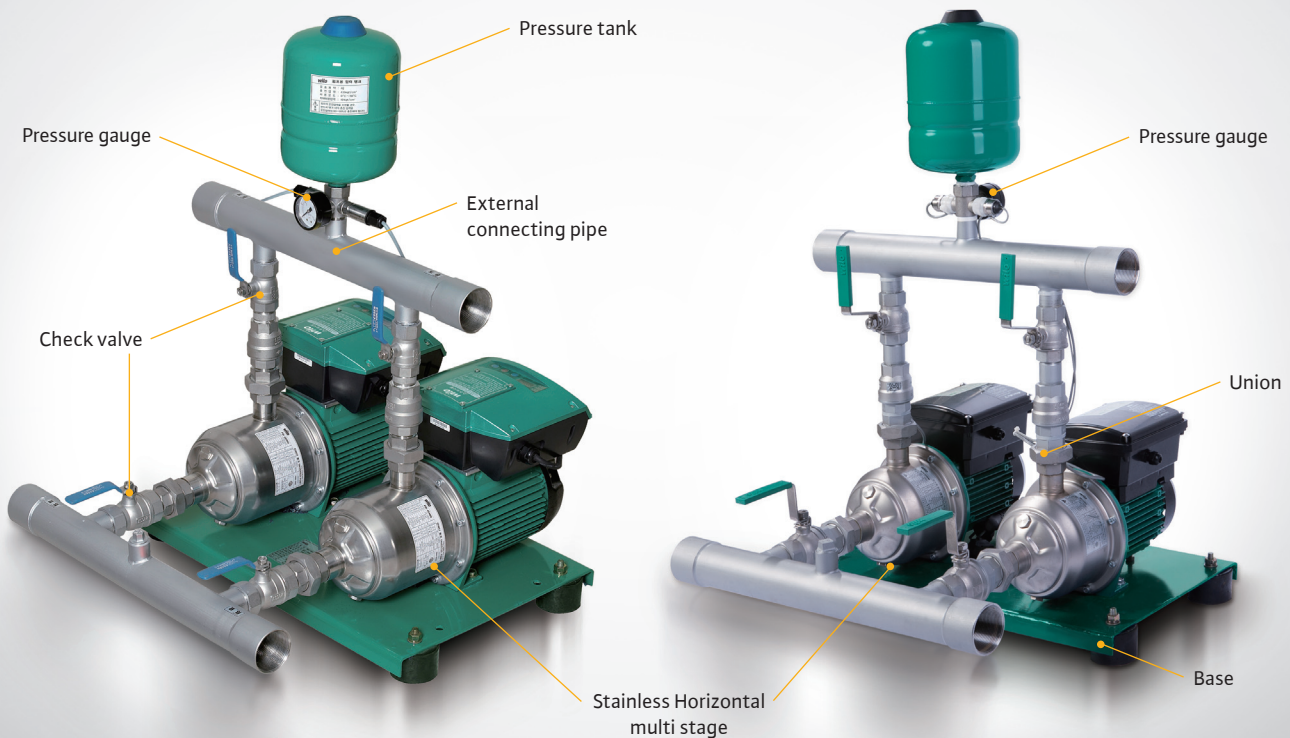

MHiKE-D Series

PBI-LD Series

MHiKE-D / PBI-LD Series

- Pump load distribution (ensure the excellent product lifetime by sharing pump load equally in the automatic operation by turns)
- Dry running protection (prevent the pump from operating without water by constant detection function)
- Operation by skipping the faulty pump
(although one of pumps is failed to operate, the other pump continuously operate so that it prevents from the sudden water supply interrupt)
- Warm-up function
(if the pump is not used for a quite some time, it operates periodically at the minimum speed so that it enables the pump to keep optimal and smooth operating as well as to detect whether the pump has a problem)

Application

- Water supply and Pressure boosting
(Big capacity, high-rise/low water pressure areas)
- Residential areas, motels, holiday houses, etc

Outline dimension

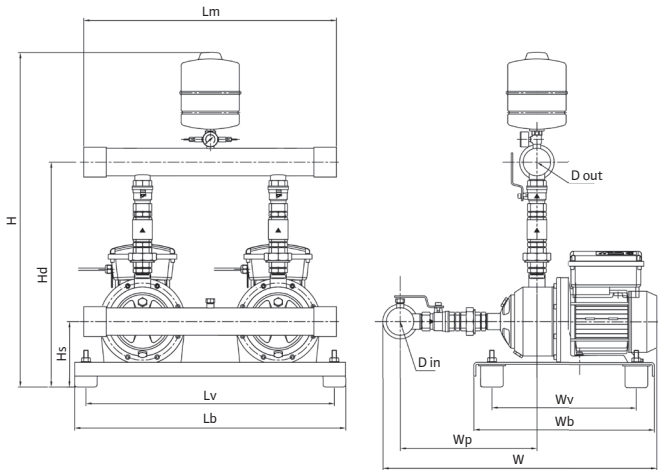

Model	Dimensions(mm)											
	H	Hs	Hd	Lm	Lv	Lb	W	Wp	Wv	Wb	Din	Dout
PBI-LD402MA	870	140	530	560	550	600	655	360	320	400	50	50
PBI-LD403MA	870	140	530	560	550	600	655	360	320	400	50	50
MHiKE-D404MA /PBI-LD404MA	870	140	530	560	550	600	655	360	320	400	50	50
MHiKE-D405MA /PBI-LD405MA	870	140	530	560	550	600	655	360	320	400	50	50
MHiKE-D802MA /PBI-LD802MA	870	140	530	560	550	600	725	360	320	400	65	65
MHiKE-D803MA /PBI-LD803MA	870	140	530	560	550	600	725	360	320	400	65	65

Performance curve

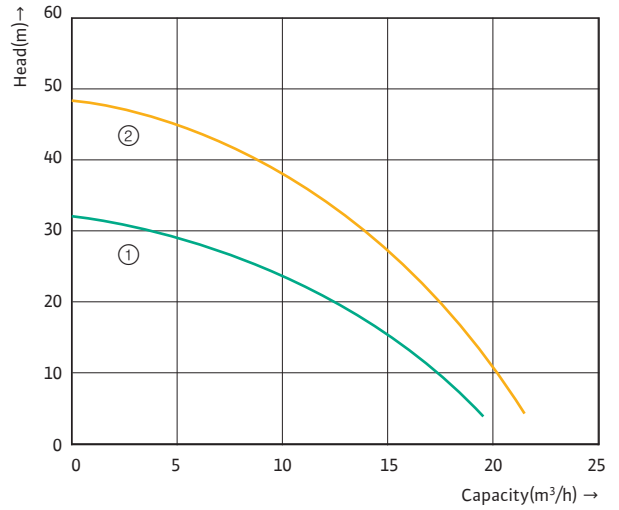

① PBI-LD402MA ② PBI-LD403MA

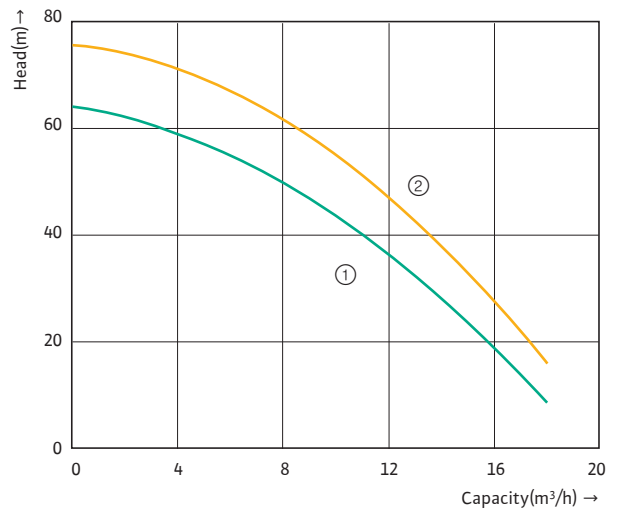

① MHiKE-D404MA/PBI-LD404MA
② MHiKE-D405MA/PBI-LD405MA

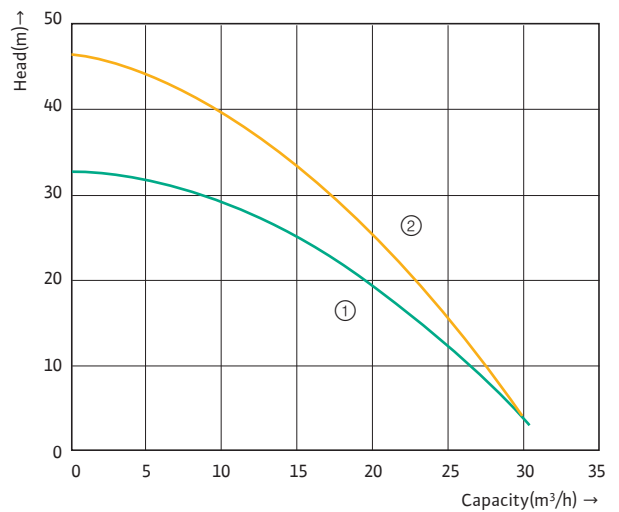

① MHiKE-D802MA/PBI-LD802MA
② MHiKE-D803MA/PBI-LD803MA

MHiKE-W/T Series

Inverter booster system (Stability of water supply)

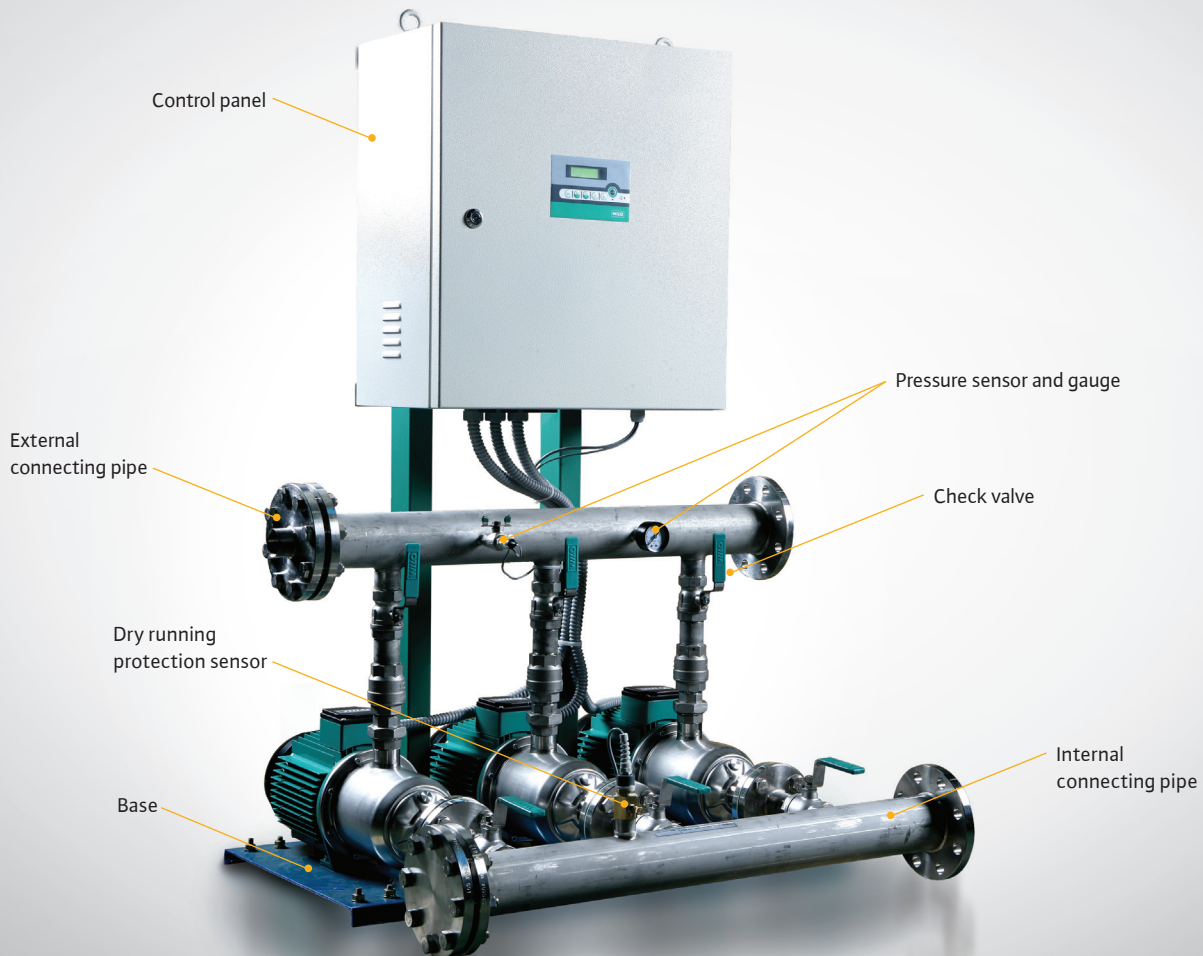

MHiKE-W/T Series

MHiKE-W/T Series

- Pump load distribution (ensure the excellent product lifetime by sharing pump load equally in the automatic operation by turns)
- Friction loss compensation function
(considering low flow friction losses, automatically changes partial pressure low flow to prevent unnecessary pressure losses for energy-saving)
- Inverter alternating cycle
(if one inverter drives over the setting time, the other pump will automatically switched to drive, this can prevent overload of a particular pump)
- Operation by skipping the faulty pump
(although one of pumps is failed to operated, the other pump continuously operate so that it prevents from the sudden water supply interrupt)

Application

- Water supply and Pressure boosting
- Small building, officetel, etc
- Construction work (instead of booster)

Outline dimension

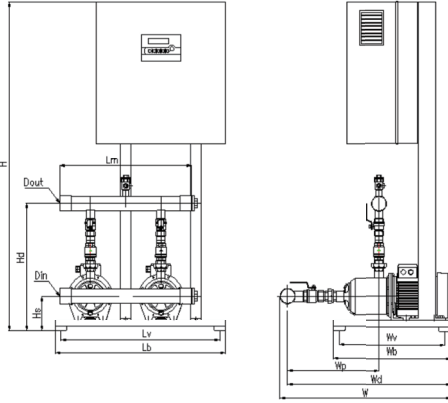

Model	Dimensions(mm)											
	H	Hs	Hd	Lv	Lb	Wv	Wb	Wp	Wd	W	Din	Dout
MHiKE-W406UA	1400	152.5	541	675	725	450	500	385	685	720	50	50
MHiKE-W804UA	1400	152.5	570	675	725	450	500	410	710	760	65	65
MHiKE-W805UA	1400	152.5	570	675	725	450	500	410	710	760	65	65

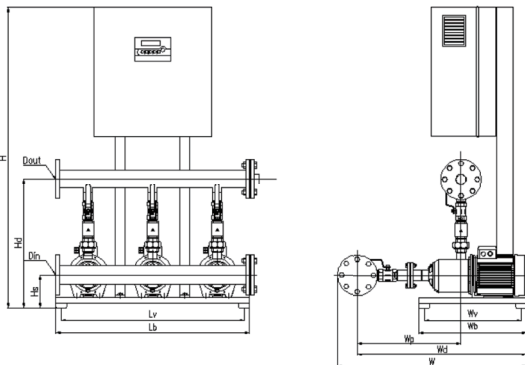

Model	Dimensions(mm)											
	H	Hs	Hd	Lv	Lb	Wv	Wb	Wp	Wd	W	Din	Dout
MHiKE-T406UA	1400	152.5	570	850	900	450	500	470	770	857	65	65
MHiKE-T804UA	1400	152.5	600	850	900	450	500	485	785	877	80	80
MHiKE-T805UA	1400	152.5	600	850	900	450	500	485	785	877	80	80

※ Performance curve

Model	Recommended pressure tank size
MHiKE-W406UA	100L
MHiKE-W804/805UA	200L
MHiKE-T406UA	100L
MHiKE-T804/805UA	200L

- Please install the pressure tank to protect pump system (prevent water hammer & reduce motor operating times)
- The size of flexible hose at the external connecting pipe is PF 1"
- Recommended pressure tank size is based on setting pressure at the factory, thus if you want to change the operation pressure, please contact with us

Performance curve

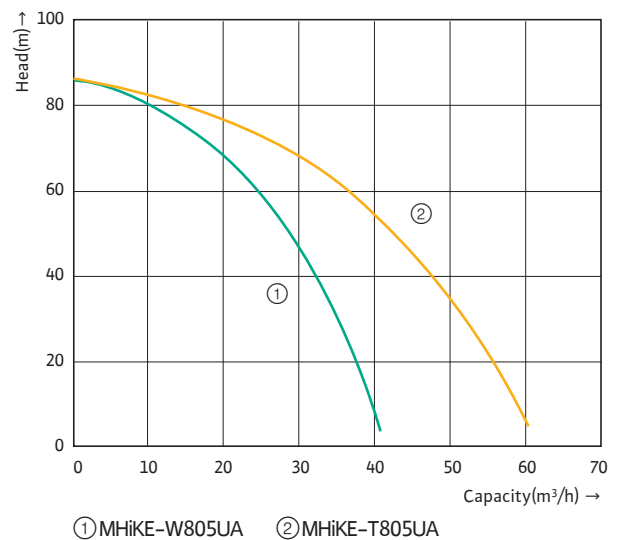
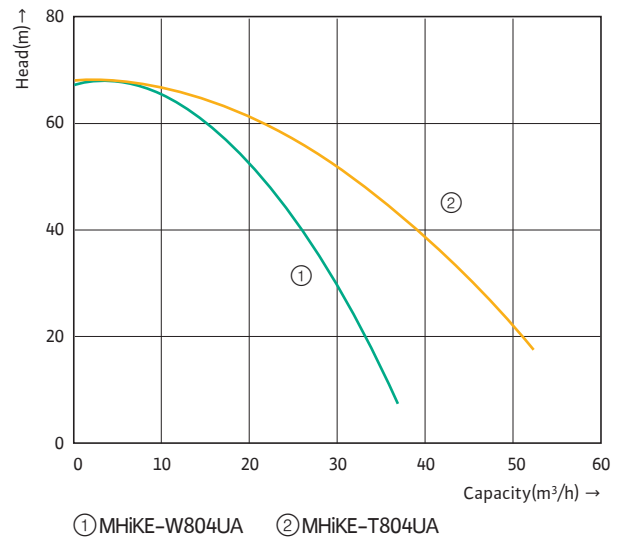
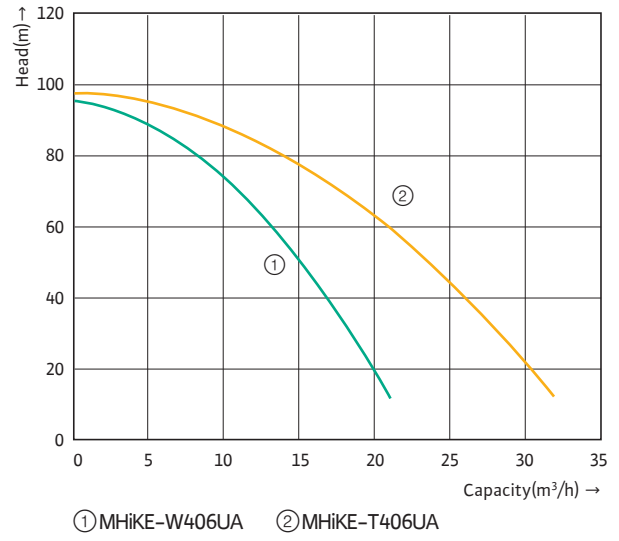



WILO SE

Nortkirchenstraße 100
D-44263 Dortmund
Germany
T +49 231 4102-0
F +49 231 4102 7363
wilo@wilo.com
www.wilo.com

WILO Pumps Ltd.

46 Mieumsandan 1-ro
Gangseo-gu Busan
618-260 Korea
T +82 51 950 8000
F +82 51 950 8369
www.wilo.co.kr