



## **Wilo NL Base Mount End Suction Pumps**

### **Installation and operating instructions**

## 1 General

### 1.1 Description

The NL (End Suction) Series centrifugal pumps are frame mounted pumps which feature: high efficiency, rugged construction, compact design, foot mounted volute, center drop out coupler, and non-regreasable bearings. These features, make installation, operation, and service easy to perform.

### 1.2 Pump Application

The standard NL (End Suction) Series centrifugal pump's bronze-fitted construction makes it ideal for service in the following applications: unheated domestic and fresh water, boiler feed water, condensate, hydronic cooling or heating, pressure boosting, chillers, geo-thermal exchange, general pumping and benign liquids.

For other applications contact your local Wilo representative.

### 1.3 Operational Limits

Unless special provisions have been made for your pump by Wilo, the operational limits for NL (End Suction) Series Pumps are as follows:

#### Maximum Working Pressure,

Listed on pump nameplate:

175 psi (12 bar) standard

250 psi (17 bar) available upon request

### 1.4 Seal Operating Limits

Standard Mechanical Seals

pH Limitations: 7-11

Temperature Range: 0 to +250°F [-20 to +120°C]

For use on closed or open systems which are relatively free of dirt and/or other abrasive particles.

### 1.5 Pump Identification

Wilo pumps are designated by a series of numbers such as NL 4x3x8-ODP-4-25-284T-460v-P). The pump nameplate gives identification and rating information as identified in Figure 1. Permanent records for this pump are kept by the serial number and therefore must be used with all correspondence and spare parts orders.

WILO					
P-Type	Pump Type	S/N Machine Number			
M-Type	Motor Type				
U	Rated Voltage	Q	Pump Flow	M	Impeller Diameter
I	Rated Current	H	Pump Head	OTSE	N/A
1st	N/A	Cos	Cosing PH1	TPF	Temp. of pumped Fluid
P	Rated Power	SF	Service Factor	∇	Max Submersion
F	Frequency	1sf	N/A	IP	Protection Class
MFY	Year of Manufacture	N	Speed	MC	Motor Wiring

Made by WILO

WILO USA, LLC  
1250 N. 25th Ave.  
Melrose Park, IL 60160

Figure 1 – Nameplate

## 2 Safety Instructions



### Safety Instructions

This safety alert symbol will be used in this manual and on the pump safety instruction decals to draw attention to safety related instructions. When used the safety alert symbol means **ATTENTION, BECOME ALERT, YOUR SAFETY IS INVOLVED! FAILURE TO FOLLOW THE INSTRUCTIONS MAY RESULT IN A SAFETY HAZARD.**

### 2.1 Instruction Decals

Your NL (End Suction) Series pump should have the following safety instruction decals displayed. If the decals are missing or illegible contact your local Wilo representative for a replacement.

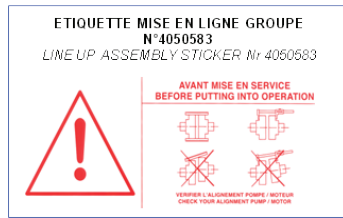
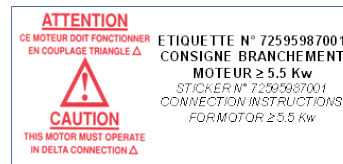

Figure 2 – Decals

### 2.2 Additional Safety Requirements

- Electrical connections are to be made by qualified electrician in accordance with all national, state and local codes.
- Motor must have properly sized starter with properly sized heaters to provide overload and under-voltage protection.
- If pump, motor or piping are operating at extremely high or low temperatures, guarding or insulation is required.
- The maximum working pressure of the pump is listed on the pump nameplate. Do not exceed this pressure!

### 2.3 Electrical Safety



### WARNING: Electrical Shock Hazard Imminently Hazardous Situation!

Electrical connections are to be made by a qualified electrician in accordance with all applicable codes, ordinances, and good practices. Failure to follow these instructions could result in serious personal injury or death, or property damage.



**WARNING: Electrical Overload Hazard**  
Potentially Hazardous Situation!

Three phase motors must have properly sized heaters to provide overload and undervoltage protection. Single phase motors have built-in overload protectors. Failure to follow these instructions could result in serious personal injury or death, or property damage.

2.4 Thermal Safety



**WARNING: Extreme Temperature Hazard**  
Potentially Hazardous Situation!

If pump, motor, or piping are operating at extremely high or low temperatures, guarding or insulation is required. Failure to follow these instructions could result in serious personal injury or death, or property damage.

2.5 Mechanical Safety



**WARNING: Unexpected Startup Hazard**  
Potentially Hazardous Situation!

If pump, motor, or piping are operating at extremely high or low temperatures, guarding or insulation is required. Failure to follow these instructions could result in serious personal injury or death, or property damage.



**WARNING: Excessive System Pressure Hazard**  
Potentially Hazardous Situation!

The maximum working pressure of the pump is listed on the nameplate. Do not exceed this pressure! Do not use air to hydrotest pump. Failure to follow these instructions could result in serious personal injury or death, or property damage.



**WARNING: Excessive Pressure Hazard – Volumetric Expansion**  
Potentially Hazardous Situation!

The heating of water and other fluids causes volumetric expansion. The associated forces may cause failure of system components and release of high temperature fluids. This will be prevented by installing properly sized and located compression tanks and pressure relief valves. Failure to follow these instructions could result in serious personal injury or death, or property damage.

3 Pump Location

Locate the pump so there is sufficient room for inspection, maintenance and service. If the use of a hoist or tackle is needed, allow ample head room.



**WARNING: Falling Objects Hazard**  
Imminently Hazardous Situation!

Eyebolts or lifting lugs, if provided, are for lifting only the components to which they are attached. Failure to follow these instructions could result in property damage, serious personal injury or death.

If lifting base pump is required, use a nylon string, chain, or wire rope, hitch around bearing bracket and the casing. If lifting of the entire pump unit is required, do so with slings placed under the base rails as shown.

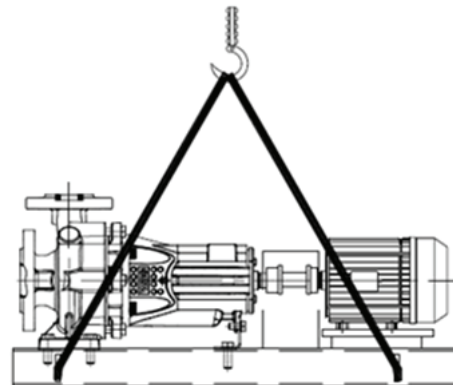
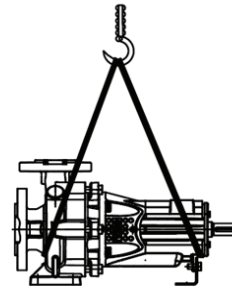

Figure 3 – Lifting Unit

The best pump location for sound and vibration absorption is on a concrete floor with subsoil underneath. If the pump location is overhead, special precautions should be undertaken to reduce possible sound transmission. Consult a sound specialist.

If the pump is not on a closed system, it should be placed as near as possible to the source of the liquid supply, and located to permit installation with the fewest number of bends or elbows in the suction pipe.

The installation must be evaluated to determine that the Net Positive Suction Head Available (NPSHA) meets or exceeds the Net Positive Suction Head Required (NPSHR), as stated by the pump performance curve.

**IMPORTANT:** Do not install and operate Wilo Pumps, Triple Duty (3-D) Valves, Suction Diffusers, etc., in closed systems unless the system is constructed with properly sized safety devices and control devices. Such devices include the use of properly sized and located pressure relief valves, compression tanks, pressure controls, temperature controls, and flow controls as appropriate. If the system does not include these devices, consult the responsible engineer or architect before making pumps operational.

## 4 Purpose of Manual

This manual is furnished to acquaint you with some of the practical ways to install, operate, and maintain this pump. Read it completely before doing any work on your unit and keep it handy for future reference. Equipment cannot operate well without proper care. To keep this unit at top efficiency, follow the recommended installation and servicing procedures outlined in this manual.

## 5 Warranty

Should your pump ever need servicing, please contact Wilo USA at 1-888-945-6872.

## 6 Pump Identification

All pumps are designated by Serial Number, Pump Series, and Size. This information is stamped on an identification plate which is mounted on the pump. Refer to the pump identification in the specific instruction section of this manual for detailed information.

## 7 Receiving Pump

It is imperative to check the pump for shortages and damage immediately upon receipt. Prompt reporting to the carrier's agent with notations made on the freight bill will expedite satisfactory adjustment by the carrier.

Pumps and drivers normally are shipped from the factory mounted and painted with single coat of primer and two finish coats. Couplings are shipped completely assembled, or in some cases, have the coupling hubs are mounted on the shafts and the connecting members removed. When the connecting members are removed, they will be packaged in a separate container and shipped with the pump or attached to the pump base plate.

Shafts are in alignment when the unit is shipped; however, due to shipping, the pumps may arrive misaligned and, therefore, **ALIGNMENT MUST BE PERFORMED DURING INSTALLATION**. Wilo has determined that proper and correct alignment can only be made by accepted installation practices. Refer to the following paragraphs on "FOUNDATION", "BASE PLATE SETTING", "GROUTING PROCEDURE" and "ALIGNMENT PROCEDURE".

## 8 Temporary Storage

If the pump is not to be installed and operated soon after arrival, store it in a clean, dry place having controlled, moderate changes in ambient temperature. Rotate the shaft periodically to coat the bearings with lubricant and to retard oxidation, corrosion, and to reduce the possibility of false brinelling of the bearings.

## 9 Location

The pump should be installed as near the suction supply as possible, but with no less than five suction diameters of straight pipe to assure laminar flow at the suction inlet. The total dynamic suction lift (static lift plus friction losses in suction line) should not exceed the limits for which the pump was sold.

The pump must be primed before starting. Whenever possible, the pump should be located below the fluid level to facilitate priming and assure a steady flow of liquid. This condition provides a positive suction head on the pump. It is also possible to prime the pump by pressurizing the suction vessel.

When installing the pump, consider its relative location to the system to assure

that sufficient Net Positive Suction Head (NPSH) at pump suction is provided. Available NPSH (NPSHA) must always equal or exceed the required NPSH (NPSHR) of the pump.

The pump should be installed with sufficient accessibility for inspection and maintenance. A clear space with ample head room should be allowed for the use of an overhead crane or hoist sufficiently strong to lift the unit.

NOTE: Allow sufficient space to be able to dismantle pump without disturbing the pump inlet and discharge piping.

Select a dry place above the floor level wherever possible. Take care to prevent pump from freezing during cold weather when not in operation. Should the possibility of freezing exist during a shut-down period, the pump should be completely drained, and all passages and pockets where liquid might collect should be blown out with compressed air. Make sure there is a suitable power source available for the pump driver. If motor driven, electrical characteristics should be identical to those shown on motor data plate.

## 10 Foundation

The foundation for your pump must be sufficiently rigid to absorb any vibration and stress encountered during pump operation. A raised foundation of concrete is preferable for most floor-mounted pumps. The raised foundation assures a satisfactory base, protects against flooding, simplifies moisture drainage, and facilitates cleanliness.

The foundation should be poured without interruption to within 1/2 to 1 1/2 inches [13-38mm] of the finished height. The top surface of the foundation should be well scored and grooved before the concrete sets; this provides a bonding surface for the grout.

Foundation bolts should be set in concrete as shown in Figure 4. An optional 4 inch [102mm] long tube around the bolts at the top of the concrete will allow some flexibility in bolt alignment to match the holes in the base plate. Allow enough bolt length for grout, shims, lower base plate flange, nuts and washers. The foundation should be allowed to cure for several days before the base plate is shimmed and grouted.

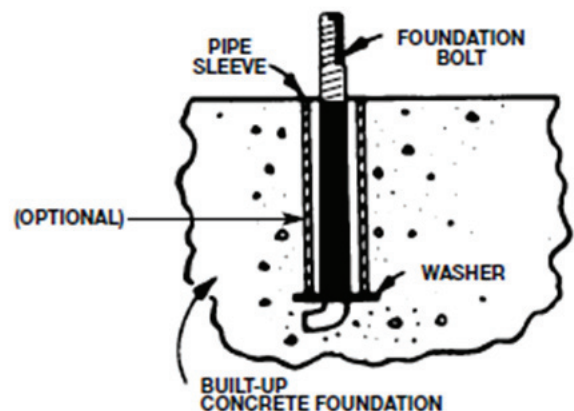

Figure 4 - Foundation

## 11 Base Plate Setting (Before Piping)

NOTE: This procedure assumes that a concrete foundation has been prepared with anchor or hold-down bolts extending upward, ready to receive unit. It must be understood that pump and motor have been mounted and rough aligned at the factory. If the motor is to be field mounted, Wilo cannot assume responsibility for final alignment.

- Use blocks and shims under base for support at anchor bolts and midway between bolts, to position base approximately 1" [25mm] above the concrete foundation, with studs extending through holes in the base plate.
- By adding or removing shims under the base, level and plumb the pump shaft and flanges. The base plate does not have to be level.
- Draw anchor nuts tight against base, and observe pump and motor shafts or coupling hubs for alignment. (Temporarily remove coupling guard for checking alignment.)
- If alignment needs improvement, add shims or wedges at appropriate positions under base, so that retightening of anchor nuts will shift shafts into closer alignment. Repeat this procedure until a temporary alignment is reached.
- NOTE: Temporary alignment is defined as that which is mutually agreed upon by pump contractor and the accepting facility (final operator). Final alignment procedures are covered under "Alignment Procedures."
- Check to make sure the piping can be aligned to the pump flanges without placing pipe strain on either flange.
- Grout in base plate completely (See "Grouting Procedure") and allow grout to dry thoroughly before attaching piping to pump. (24 hours is sufficient time with approved grouting procedure.)

## 12 Grouting Procedure

Grout compensates for uneven foundation, distributes weight of unit, and prevents shifting and vibration. Use an approved, non-shrinking grout, after setting and leveling unit (See figure 5).

- Build strong form around the foundation to contain grout.
- Soak top of concrete foundation thoroughly, then remove surface water.
- Base plate should be completely filled with grout.
- After the grout has thoroughly hardened, check the foundation bolts and tighten if necessary.
- Check the alignment after the foundation bolts are tightened.
- Approximately 14 days after the grout has been poured or when the grout has thoroughly dried, apply an oil base paint to the exposed edges of the grout to prevent air and moisture from coming in contact with the grout.

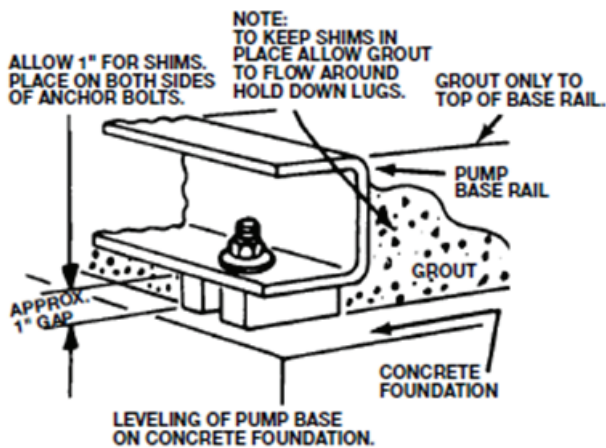

Figure 5 - Setting Base Plate and Grouting

## 13 Coupling Guard Removal / Installation



**WARNING: Unexpected Start-Up Hazard Potentially Hazardous Situation!**

**Disconnect and lock out power before servicing. Failure to follow these instructions could result in serious personal injury or death and property damage.**

### 13.1 Removal

- Remove the screws, clips, and washers holding the coupler guard halves together.
- Remove the upper and lower coupler guard halves from the coupler guard support plate which is assembled to the drive end (inboard) of the pump.

### 13.2 Installation

- Check coupler alignment before proceeding. Correct if necessary, see pages 6 & 7 for tolerance.
- Attach the upper and lower coupler guard halves onto the groove in the coupler guard support plate
- Attach the existing screws and washers to the upper coupler guard half.
- Attach the clip onto the lower coupler guard half.
- Fasten coupler guard hardware, see Figure 6.

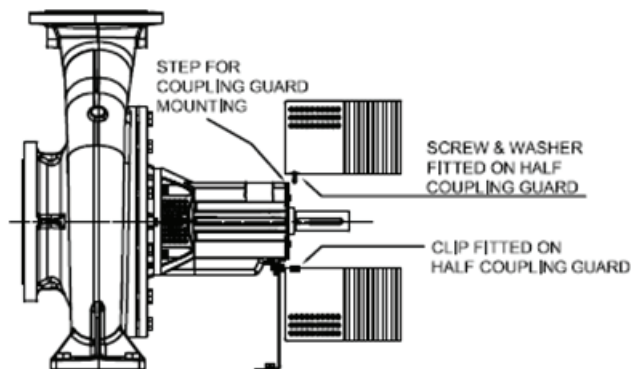

Figure 6 - Coupler Guard Installation

### 13.2 Replacement of Coupler Guard

- New replacement coupler halves will be longer than the existing ones.
- Check the required guard length from the coupler guard support plate to the motor face.
- Mark the length on the guard halves.
- Cut the guard halves at the grooves.
- Check coupler alignment before proceeding. Correct if necessary.
- Attach the upper and lower coupler guard halves onto the groove in the coupler guard support plate.
- Attach the existing screws and washers to the upper coupler guard half.
- Attach the clip onto the lower coupler guard half.
- Fasten coupler guard hardware.

## 14 Alignment Procedure

NOTE: A 'flexible coupling' will only compensate for small amounts of misalignment. Permissible misalignment will vary with the make of coupling. Consult coupling manufacturer's data for specific tolerances.

Allowances are to be made for thermal expansion during cold alignment, so that the coupling will be aligned at operating temperature. In all cases, a coupling must be in alignment for continuous operation. Even though the coupling may be lubricated, misalignment causes excessive wear, vibration, and bearing loads that result in premature bearing failure and ultimate seizing of the pump. Misalignment can be angular, parallel, or a combination of these, and in the horizontal and vertical planes. Final alignment should be made by moving and shimming the pump or motor on the base plate, until the coupling hubs are within the recommended tolerances measured in total run-out. All measurements should be taken with the pump and motor foot bolts tightened. The shaft of sleeve bearing motors should be in the center of its mechanical float.

NOTE: Proper alignment is essential for correct pump operation. This should be performed after base plate has been properly set and grout has dried thoroughly according to instructions. Final alignment should be made by shimming driver only. Alignment should be made at operating temperatures.



### **WARNING: Unexpected Start-up Hazard Potentially Hazardous Situation!**

**Disconnect and lock out power before servicing. Failure to follow these instructions could result in property damage, serious personal injury, or death.**

#### 14.1 Initial Alignment of the Flexible Coupling (See figure 7)

The pump and driver were accurately aligned at the factory. However, it is impossible to maintain this alignment during shipping and handling. Therefore it will be necessary to realign the pump and driver. Flexible couplings are not universal joints. They should not be used to compensate for misalignment of the pump and motor shafts. Their function is to transmit power from the driver to the pump while compensating for thermal expansion and shaft end movement. The coupling faces should be far enough apart so that they do not make contact when the motor shaft is forced to the limit of the bearing clearance toward the pump shaft.

In order to properly align the coupling, you will need a taper gauge or set of feeler gauges, and a straight edge.

There are two types of misalignment encountered with flexible couplings: angular misalignment, in which the shafts are not parallel, and parallel misalignment where the shafts are parallel but not on the same axis.

To check angular alignment:

- Insert a feeler gauge or taper gauge at any four places 90° apart around the coupling halves.
- Insert shims under the driver feet until the same reading is obtained at all four check points.
- The pump and driver will then be in angular alignment.

To check parallel alignment:

- A straight edge should be held against the edges of the coupling halves at any four places 90° apart around the coupling.
- The straight edge should be parallel to the pump and driver shafts at all times.
- Insert shims until the straight edge lies flat against both coupling halves at all four checkpoints.
- The pump and driver will then be in proper parallel alignment.
- **IMPORTANT:** Reapply loctite® 243 to pump and/or motor mounting screws to prevent loosening during operation.

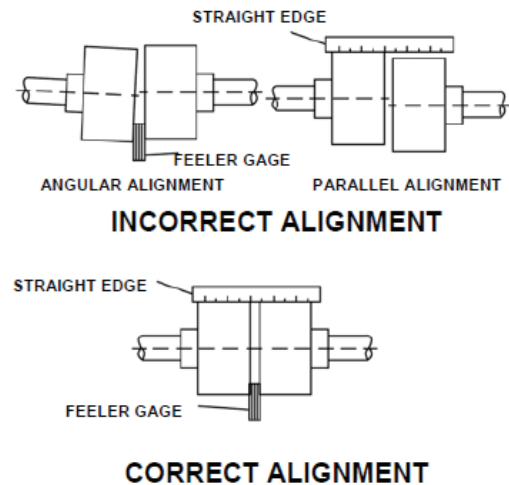

Figure 7 - Checking Alignment (Straight Edge Method)

#### 14.2 For Fine Alignment, 3500 RPM OPERATION, For Other Coupler Types (See figure 8)

A dial indicator should be used when greater alignment accuracy is required. Use the following alignment tolerances unless otherwise specified by the coupling manufacturer. On sleeve-type couplings make sure there is at least 1/8 inch [3mm] end clearance between the sleeve and the two coupling halves.

To check angular misalignment:

- Mount the dial indicator base to the coupling half and position the dial indicator button on the front or rear face of the opposite coupling half.
- Set the dial to zero, rotate both coupling halves together, making sure the indicator button always indicates off the same spot.
- Misalignment values are within 0.004 inches [.10mm] TIR per inch [25mm] of coupler radius is permissible.

To check parallel misalignment:

- Mount the dial indicator base to one coupling half or the shaft and position the dial indicator button on the outside diameter of the opposite coupling half.
- Set the dial to zero and rotate both coupling halves together, making sure the indicator button always indicates off the same spot.
- Misalignment are within 0.004 inches [.10mm] TIR is permissible.

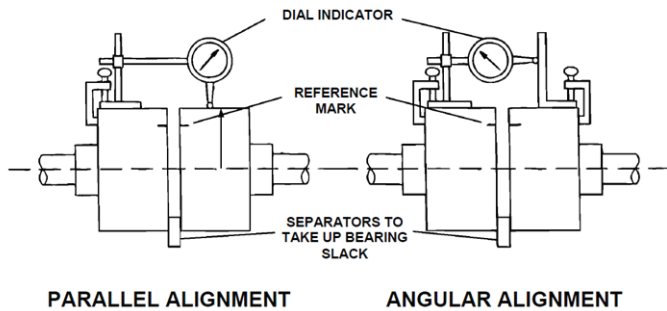

Figure 8 - Checking Alignment (Dial Indicator Method)

NOTE: Final alignment cannot be accomplished until the pump has been operated initially for a sufficient length of time to attain operating temperature. When normal operating temperature has been attained, secure the pump to re-check alignment and compensate for temperature accordingly.

IMPORTANT: Reapply loctite® 243 to pump and/or motor mounting screws to prevent loosening during operation.



**WARNING: Rotating Components Hazard**  
Potentially Hazardous Situation!

Do not operate pump without all guards in place. Failure to follow these instructions could result in property damage, serious personal injury, or death.

**15 Suction and Discharge Piping - General Precautions**

When installing the pump piping, be sure to observe the following precautions:

- Piping should always be run to the pump. Do not move pump to pipe, as this will could make final alignment impossible.
- Both the suction and discharge piping should be supported independently near the pump and properly aligned, so that no strain is transmitted to the pump when the flange bolts are tightened. Use pipe hangers or other supports at necessary intervals to provide support. When expansion joints are used in the piping system, they must be installed beyond the piping supports closest to the pump. Tie bolts should be used with expansion joints to prevent pipe strain. Do not install expansion joints next to the pump or in any way that would cause a strain on the pump resulting from system pressure changes. It is usually advisable to increase the size of both suction and discharge pipes at the pump connections to decrease the loss of head from friction.
- Install piping as straight as possible, avoiding unnecessary bends. Where necessary, use 45° or long sweep 90° fittings to decrease friction losses. To decrease friction losses, install piping as straight as possible, keeping in mind - desired 5 straight pipe diameters and laminar flow to the suction inlet.
- Make sure that all piping joints are airtight.
- Where flanged joints are used, assure that inside diameters match properly.
- Remove burrs and sharp edges when making up joints.
- Do not “spring” piping when making any connections.
- Provide for pipe expansion when hot fluids are to be pumped.

**15.1 Reducers**

Eccentric reducers should be installed directly at the suction nozzle, with the taper at the bottom to prevent air pockets from forming. Straight taper reducers should never be used in a horizontal suction line because of the air pocket that

is formed at the leg of the reducer and the pipe. (See Figure 9).

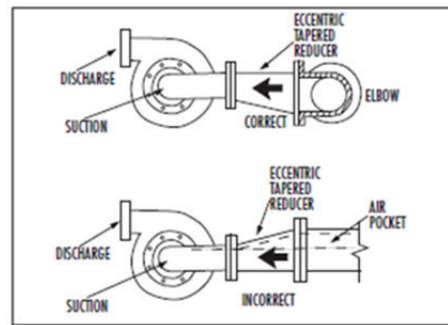

Figure 9 - Installation of Eccentric Tapered Reducers

**15.3 Discharge Piping - Precautions and Recommendations**

Discharge piping should also be short and direct as possible, with few elbows and fittings, to reduce head loss from friction.

The discharge pipe diameter should be the same as, or larger than, the discharge nozzle diameter.

**15.4 Valves in Discharge - Piping Precautions and Recommendations**

The discharge piping should include a check valve and a gate valve. The check valve should be located between the gate valve and the pump. If an increaser is used in the discharge piping, the increaser should be installed between the pump nozzle and the check valve. The check valve protects against a reverse flow of the liquid if the driver fails. (See Figure 10).

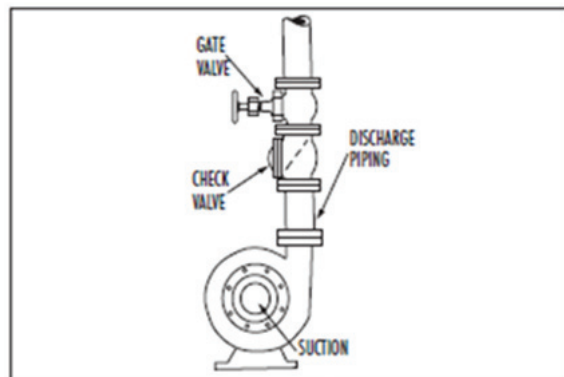

Figure 10 - Gate Valve and Check Valve

The gate valve is used in the priming operation as a throttling valve to control pump volume, and to shut down the pump for inspection and maintenance.

**16 Pressure Gauges - Precautions and Recommendations**

Properly sized pressure gauges should be installed in both the suction and discharge nozzles in the gauge taps. The gauges will enable the operator to easily observe the operation of the pump to determine if it is conforming to its performance curve. If cavitation, vapor binding, or other unstable operation should occur, excessively fluctuating discharge pressure will be noted.

**17 Pump Insulation - Precautions and Recommendations**

On chilled water applications most pumps are insulated. As part of this practice, the pump bearing housing grease fittings should be accessible. The vent slots on the sides and bottom of the bearing assembly should remain uncovered and

completely open. Otherwise, this would tend to “trap” heat inside the housing. This could lead to increased bearing temperatures and premature bearing failures.

## 18 Mechanical Seals – Precautions and Recommendations

Mechanical seals are preferred over packing on most applications because of better sealing qualities and longer serviceability. Leakage is eliminated when a seal is properly installed, and normal life is much greater than that of packing on similar applications.

Pumps containing single mechanical seals normally utilize the pumped liquid to lubricate the seal faces. This method is preferred when the pumped liquid is neither abrasive nor corrosive.

## 19 Operation

### 19.1 Pre-Start Checks

Before initial start of the pump, make the following inspections:

- Check alignment between pump and motor, see pages 6 & 7.
- Check all connections to motor and starting device. Check voltage, phase, and frequency on motor nameplate with line circuit.
- Check suction and discharge piping and pressure gauges for proper operation.
- Turn pump shaft by hand to assure that it rotates freely.
- Inspect that pump bearings are properly lubricated, see coupling manufacturer's IOM for instructions.
- Assure that coupling is properly lubricated, if required.
- Assure that pump is full of liquid ('PRIMING') and all valves are properly set and operational, with the discharge valve closed, and the suction valve open.
- Check rotation. Be sure that the drive operates in the direction indicated by the arrow on the pump casing as serious damage can result if the pump is operated with incorrect rotation.
- Check rotation each time the motor leads have been disconnected.



### **WARNING: Rotating Components Hazard** Potentially Hazardous Situation!

**Do not operate pump without all guards in place. Failure to follow these instructions could result in property damage, serious personal injury or death.**



### **CAUTION: Seal Damage Hazard**

**Do not run pump dry, seal damage may occur. Failure to follow these instructions could result in property damage, serious personal injury or death.**

### 19.2 Priming

If the pump is installed with a positive head on the suction, it can be primed by opening the suction and vent valve and allowing the liquid to enter the casing.

If the pump is installed with a suction lift, priming must be done by other methods such as foot valves, ejectors, or by manually filling the casing and suction line through the gauge ports.



### **WARNING: Rotating Components Hazard** Potentially Hazardous Situation!

**Do not operate pump without all guards in place. Failure to follow these instructions could result in property damage, serious personal injury or death.**

### 19.3 Starting

- Close drain valves and valve in discharge line.
- Open fully all valves in the suction line.
- Prime the pump.
- NOTE: If the pump does not prime properly, or loses prime during start-up, it should be shut down and the condition corrected before the procedure is repeated.
- When the pump is operating at full speed, open the discharge valve slowly. This should be done promptly after start-up to prevent damage to pump by operating at zero flow.

### 19.4 Operating Check

- Check the pump and piping to assure that there are no leaks.
- Check and record pressure gauge readings for future reference.
- Check and record voltage, amperage per phase, and power (kW) if a wattmeter is available.
- Check bearings for lubrication and temperature. Normal temperature is 180°F [82°C] maximum.
- Make all pump output adjustments with the discharge line.



### **CAUTION: Cavitation Damage Hazard**

**Do not throttle the suction line to adjust the pump output. Failure to follow these instructions could result in property damage.**

### 19.5 Freezing Protection

Pumps that are shut down during freezing conditions should be protected by one of the following methods.

- **Drain the pump; remove all liquids from the casing.**
- **Keep fluid moving in the pump and insulate or heat the pump to prevent freezing.**



### **CAUTION: Bearing/Seal Damage Hazard**

**Do not let the pump temperature rise above 200°F [93°C] measured at the bearing housing. Failure to follow these instructions could result in property damage and/or moderate personal injury.**





**WARNING: Rotating Components Hazard**  
Potentially Hazardous Situation!

**Do not operate pump without all guards in place. Failure to follow these instructions could result in property damage, serious personal injury or death.**

**19.6 Troubleshooting**

Between regular maintenance inspections, be alert for signs of motor or pump trouble. Common symptoms are listed below. Correct any trouble immediately and AVOID COSTLY REPAIR AND SHUTDOWN.

**20 Maintenance**

**20.1 General Maintenance**

Operating conditions vary so widely that to recommend one schedule of preventive maintenance for all centrifugal pumps is not possible. Yet some sort of regular inspection must be planned and followed. Keep a permanent record of the periodic inspections and maintenance performed on the pump. Following a routine maintenance program will keep the pump in good working condition and prevent costly breakdown.

One of the best rules to follow in the proper maintenance of the centrifugal pump is to keep a record of actual operating hours. Then, after a predetermined period

of operation has elapsed, the pump should be given a thorough inspection. The length of this operating period will vary with different applications, and can only be determined from experience. New equipment, however, should be examined after a relatively short period of operation. The next inspection period can be lengthened somewhat. This system can be followed until a maximum period of operation is reached which should be considered the operating schedule between inspections.

**20.2 General Maintenance of Flooded Pumps**



**WARNING: Unexpected Startup Hazard**  
Potentially Hazardous Situation!

**Disconnect and lockout power before servicing. Failure to follow these instructions could result in injury, death, or property damage.**

The servicing of centrifugal pumps after a flooded condition is a comparatively simple matter under normal conditions.

Bearings are a primary concern on pumping units. First, dismantle the bearing bracket, clean and inspect the bearings for any rusted or badly worn surfaces. If bearings are free from rust and wear, reassemble them into the bearing frame. Re-lubrication is not necessary since the bearings are sealed. Depending on the length of time the pump has remained in the flooded area, it is unlikely that bearing replacement is necessary; however, in the event that rust or worn

Problems	Causes	Remedies
<b>Output too low</b>	Back pressure too high	Check the plant for contamination. Regulate a new operating point.
	Pump or pipe work not completely filled	Vent and fill the pump as well as the suction of in flow line.
	Suction lift too high or positive suction head too low	Check the liquid level; open the shut off valves on the suction side. Clean the filters.
	Impeller seeing gap too large	Replace worn parts
	Wrong direction of rotation	Change the motor connection
<b>Pump does not prime or only intermittently</b>	Pump casing, shaft seal, foot valve or suction line leads	Replace the casing seal. Check the shaft seal, Check the flange connections
	Suction lift too high or positive suction head too low.	Check the liquid level; open the shutoff valves on the suction side. Clean the filters on the suction side.
	Loose or jammed parts in the pump	Open and clean the pump
<b>Pump leaks</b>	Casing bolts not correctly tightened	Check the lightening torque of the casing bolts
	Mechanical seal leaks	Check the seal surfaces and rubber material of the mechanical seal. In case of damages exchange mechanical seal.
<b>Temperature of the pump increases</b>	Pump or pipe work not completely filled	Vent and fill the pump as well as the suction line or in flow line.
	Suction lift too high or positive suction head too low	Check the liquid level; open the shut off valves on the suction side. Clean the filters on the suction side.
	Pump is run again closed valve	Open the shut off valve on discharge side.
<b>Noisy pump</b>	Pump or pipe work not completely filled	Purge of air the pump and the pipe work.
	Suction lift too high or positive suction head too low	Check the liquid level; open the shut off valves on the suction side. Clean the filters on the suction side.
	Pump is not properly leveled or is distorted	Check the pump leveling and alignment.
	Foreign material in the pump	Dismantle and clean the pump
<b>The motor contractor trips</b>	Pump is not properly leveled or is distorted	Check the pump leveling and alignment.
	Earth fault	Check the earth connection. Check the potential causes such as damaged wirings or cables, leakages on the electrical parts.
	Operating conditions outside of performance range of pump	Refer to pump operating conditions stated in technical data
	Loose or jammed parts in the pump	Open and clean the pump.

**Table 1 – Trouble Shooting Chart**

surfaces appear, it may be necessary to replace the bearings.

Next, inspect the back cover, and clean out any foreign matter that might clog the box. Packing that appears to be worn, or no longer regulates leakage properly should be replaced. Mechanical seals should be cleaned and thoroughly flushed.

Couplings should be dismantled and thoroughly cleaned. Lubricate the coupling with one of the coupling manufacturer's recommended lubricants where required.

## 21 Lubrication

### 21.1 Grease Lubrication of Bearings

Excess grease is the most common cause of overheating therefore the ball bearings are supplied with seals or shields from the factory. Additional grease is not needed on these pumps because they are 'greased for life'.

The bearings should be watched the first hour or so after the pump has been started to see that they are operating properly.

### 21.2 Bearing Temperature

Normally the maximum desirable operating temperature for ball bearings is 180°F [82°C]. Special designs may have higher limits. Should the temperature of the bearing frame rise above the limit, the pump should be shut down to determine the cause. Check with an accurate temperature measuring device to be sure.

### 21.3 Coupling Lubrication

Flexible, rubber element type couplings (Lovejoy Jaw Type, Wood's Sure-Flex or Falk Wrap Flex coupling) provide smooth transmission of power. There is no rubbing action of metal against rubber to cause wear. Couplings are not affected by abrasives, dirt, or moisture. This eliminates the need for lubrication or maintenance, and provides clean and quiet performance.

If other type of couplings are used, follow maintenance instructions of coupling manufacturers.

## 22 Mechanical Seal Information

General instructions for operation of the various mechanical sealing arrangements are included below. It is not feasible to include detailed instructions for all mechanical seals in this booklet because of the almost unlimited number of possible combinations and arrangements. Instead, seal manufacturer's instructions will be included as a separate supplement to this book, where required.

- Mechanical seals are precision products and should be treated with care. Use special care when handling seals. Clean oil and clean parts are essential to prevent scratching the finely lapped sealing faces. Even light scratches on these faces could result in leaky seals.
- Normally, mechanical seals require no adjustment or maintenance except routine replacement of worn or broken parts.
- A mechanical seal which has been used should not be put back into service until the sealing faces have been replaced or relapped. (Relapping is generally economical only in seals two inches [50mm] in size and above.)

Four important rules which should always be followed for optimum seal life are:

1. Keep the seal faces as clean as possible.
2. Keep the seal as cool as possible.
3. Assure that the seal always has proper lubrication.
4. If seal is lubricated with filtered fluid, clean filter frequently.

## 23 Cleaning without Dismantling Pump

A short section of pipe so designed that it can be readily dropped out of the line can be installed adjacent to the suction flange. With this arrangement, any matter clogging the impeller is accessible by removing the pipe section. If the pump cannot be freed of clogging after the above methods have been tried, dismantle the unit as previously described to locate the trouble.

## 24 Disassembly and Assembly Instructions

The procedure outlined in this section covers the dismantling and reassembly of the NL (End Suction) Series pump with mechanical seals on the shaft.

When working on the pump, use accepted mechanical practices to avoid unnecessary damage to parts. Check clearances and conditions of parts when pump is dismantled and replace if necessary. Steps should usually be taken to restore impeller and neck ring clearance when it exceeds three times the original clearance.

### 24.1 Recommended Tools and Instruments

- Chain pulley block
- Wire rope
- Set of eye bolts
- Set of Open-ended spanner wrenches
- Set of Allen keys
- Set of feeler gauges
- Drill & drill bits
- Bearing puller
- Bearing induction heater
- Loctite ® 577 used on pipe plugs
- Calibrated Vernier Caliper
- Calibrated Micrometer
- Calibrated torque wrench

### 24.2 Service Instructions for Replacement of Mechanical Seals on Shaft



#### **WARNING: Electrical Shock Hazard Potentially Hazardous Situation!**

**Disconnect and lock out power before servicing. Failure to follow these instructions could result in property damage, serious injury or death.**

1. Close valves on suction and discharge sides of pump. (If no valves have been installed, it will be necessary to drain the system.)

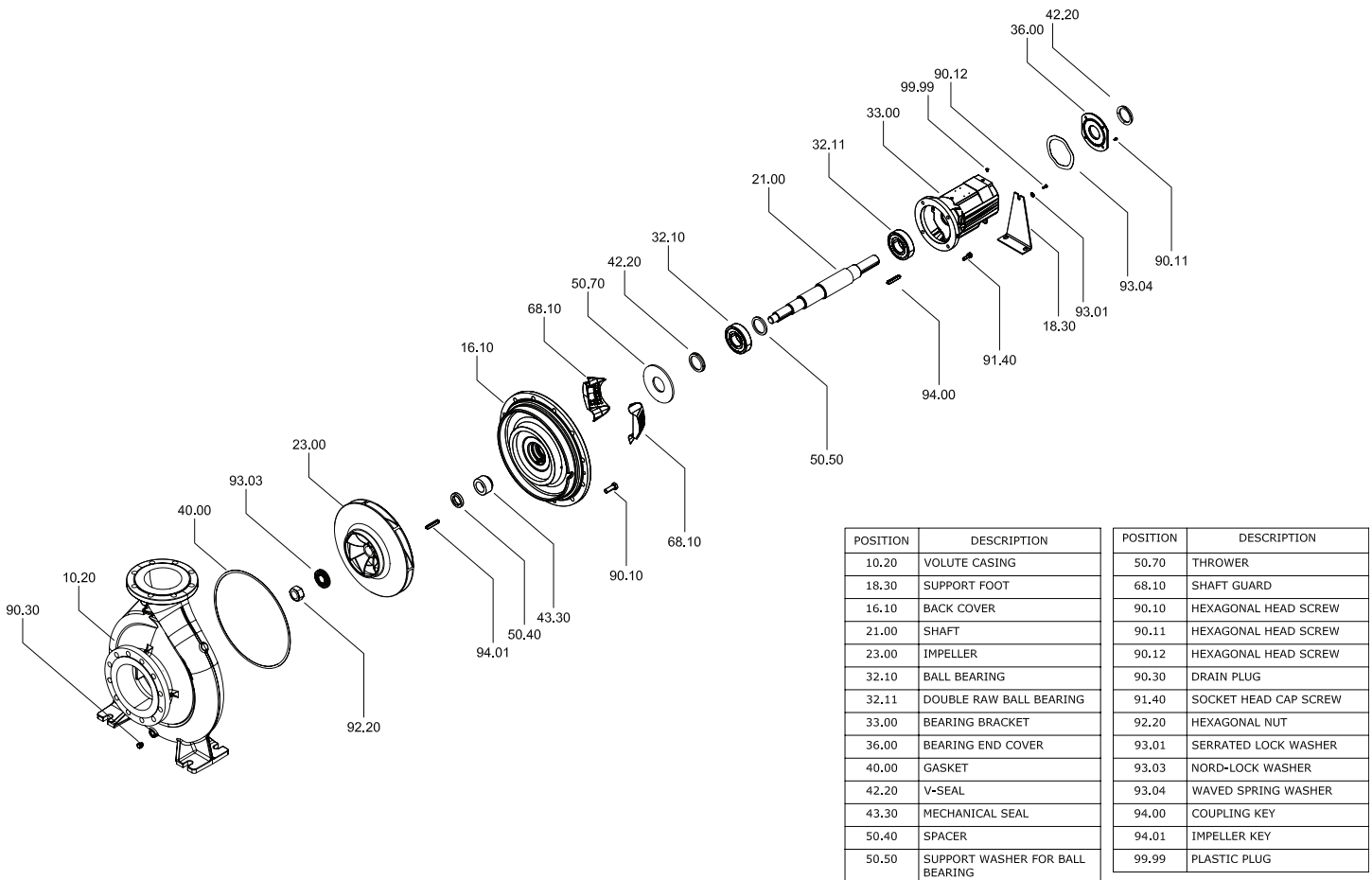

Figure 11 – Exploded View of NL (End Suction) Series Pump



**CAUTION: Extreme Temperature Hazard**

Allow pump temperatures to reach acceptable levels before proceeding. Open drain valve, do not proceed until liquid stops coming out of drain valve. If liquid does not stop flowing from drain valve, isolation valves are not sealing and should be repaired before proceeding. After liquid stops flowing from drain valve, leave drain valve open and continue. Remove the drain plug located on the bottom of the pump housing. Do not reinstall plug or close drain valve until reassembly is completed. Failure to follow these instructions could result in property damage and/or moderate personal injury.

2. Remove coupler guard (Refer to the following paragraph “COUPLING GUARD REMOVAL/ INSTALLATION” and disconnect coupler.
3. Loosen set screws in both coupler halves and slide each half back as far as possible on its shaft. Remove coupler sleeve. Where a full diameter impeller is used, it may be necessary to remove the pump side coupler half and to slide the motor back on its base in order to gain sufficient clearance to remove the pump assembly from the volute.
4. Remove the protective screen attached to the bearing housing.
5. Remove the support foot hex head capscrews.



**CAUTION: Excessive Pressure Hazard**

Make certain the internal pressure is relieved before continuing. Failure to follow these instructions could result in property damage, serious injury or death.

6. Remove the casing capscrews.
7. Remove the pump assembly from the volute casing.
8. Remove the impeller nut and Nord®-lockwasher.

9. Remove the impeller and impeller key.
10. Remove the bearing bracket fasteners.
11. Remove the shaft spacer.
12. Remove the rotating portion of the mechanical seal.
13. Remove the bearing bracket from the casing back cover.
14. Remove the stationary part of the mechanical seal from the casing back cover. See Picture 1.



Picture 1 – Mechanical Seal

15. Remove the water thrower and the v-seal from the shaft.
16. Remove the wave spring washer.
17. Remove the bearing end cover.
18. Remove the v-seal from the shaft end on the drive side (inboard end).
19. Remove the shaft with bearings from the bearing bracket.
20. Disassemble the bearings from the shaft.

**24.3 Re-assembly Procedure**

1. Heat new ball bearings, using either a dry heat (induction heater) or a 10 to

15% soluble oil and water solution.

**IMPORTANT: Do not exceed 275°F [135°C].**

- Using gloves press the heated bearings onto the shaft against support washers.
- Insert shaft with bearings into the bearing housing by tapping on the end of the pump shaft.
- Reinstall the wave spring washer.
- Re-install the bearing cover and tighten the screws in the proper sequence to 4.5 ft-lb [6 N-m].

**NOTE: Tighten the screws in a cross or star configuration (like lug nuts on car tire). This is necessary to maintain equal pressure on the outer race of the drive end (inboard) bearing.**

- Re-install the v-seal onto the shaft against the bearing cover.
- Re-install the v-seal onto the non-drive end of the shaft.
- Reassemble the water thrower.
- Install new stationary portion of the mechanical seal in the bore of the casing bracket. NOTE: Make sure the rubber boot of the mechanical seal is properly seated or possible leakage could occur.
- Reassemble the bearing bracket and shaft assembly to the casing bracket.
- Torque the bolts to 18.5 ft-lb [25 N-m] for M10 screws or 29.5 ft-lb [40 N-m] for M12 screws.
- Install new rotating portion of the mechanical seal until the two faces of the seal are touching. Use soapy water to help install the seal onto the shaft. **NOTE: this must be done within 12 minutes or else the adhesive on the rubber bellows will setup thus causing the seal to leak.**
- Reinstall shaft spacer.
- Lightly apply Molykote® on the impeller neck diameters.
- Install impeller, impeller key, impeller nut, and Nord®-lockwasher. Tighten nut to proper torque.

- For M18 nut apply 92 ft-lb [125 N-m]
- For M24 nut apply 221 ft-lb [300 N-m]
- For M30 nuts apply 369 ft-lb [500 N-m]

- Install new volute gasket (40.00) then install pump assembly into volute. Tighten volute capscrews to proper torque.

- For M10 screw apply 37 ft-lb [50 N-m]
- For M12 screw apply 66 ft-lb [90 N-m]

- Install support foot capscrews and tighten to 18.5 ft-lb [25 N-m].
- Reinstall protective screens onto bearing bracket.
- Install coupler and align. Install drain plug, close drain valve.
- Install couple guard. See Coupler Guard Removal/Installation Section.
- Open isolation valves, inspect pump for leaks, if not leaking, return pump to service.

## 25 Necessary Replacement of Hydraulic Components

The following components must always be replaced when the pump is disassembled:

- Bearings
- Gaskets
- V-Seals
- Mechanical seals
- Casing Neck Ring (if present)

**NOTE: Examine the following components for wear or damage and also, measure clearance/tolerance. If found excessive, then immediately replace the following components.**

- Casing Neck Ring (if present)
- Impeller
- Bearings
- Mechanical seal faces

## 26 Ordering Parts

The pumps covered by this manual have been designed and built with certain replaceable wearing parts. The recommended inventory of spare parts depends upon the installation and the importance of continued operation.

For critical service requiring a minimum of “downtime” a complete or a “quick change” rotating element is recommended.

For normal service, with repairs to be made in the field, the following parts are recommended for stock.

- 1 set of bearings
- 1 set of casing neck rings (if present)
- 1 set of gaskets
- 1 sets of mechanical seals (complete)
- 1 set of v-seals

Parts should be ordered as far in advance of their use as possible since circumstances beyond the control of the company may reduce existing stock. Not all parts are stocked and must be manufactured for each order.

To facilitate rapid handling of your order for spare parts, be sure to include the following information:

- Serial number of the pump.
- Article /part number of the part.
- Quantity of each part.
- Name /description of the part.
- Material desired. (Parts will be furnished in original materials unless specified as a material change. All material substitutions should be discussed with the factory.)

## 27 Fastener Torque Requirements (See Table 2)

## 28 Dealer Servicing

If trouble occurs that cannot be rectified, contact your local Wilo Representative. He/she will need the following information in order to give you assistance.

- Complete nameplate data of pump and motor.
- Suction and discharge pipe pressure gauge readings.
- Ampere draw of the motor.
- A sketch of the pumping hook-up and piping.

## 30 Motor

For motor issues, consult the Motor Instruction, Operation and Maintenance Manual.





Note: Reapply Loctite® 243 to pump and/or motor mounting screens to prevent loosening during operation.

Torque values are as noted unless otherwise specified.

### Table 2 – Torque Requirements Chart

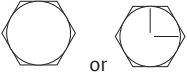



**Capscrew Torque (Foot-Pound)**

**Capscrew Diameter**

Head Marking	Capscrew Type	¼	5/16	3/8	7/16	½	5/8	¾	7/8	1	1¼
	SAE Grade 2	6	13	25	38	60	120	730	210	300	375
 or 	Brass Stainless Steel	4	10	17	27	42	83	130	200	300	375
	SAE Grade 5	10	20	35	60	90	180	325	525	800	1000
	SAE Grade 8	13	28	46	75	115	225	370	590	395	1300

**Capscrew Torque (Newton-Meter)**

**Capscrew Diameter**

Head Marking	Capscrew Type	M6	M8	M10	M12	M14	M16	M18	M20	M24	M27	M30
	ISO 4.6	8	14	33	60	100	150	165	245	320	410	550
	ISO 8.8	9	22	44	75	120	185	240	300	500	600	725
	ISO 10.9	12	28	51	98	145	225	295	390	600	800	930
	ISO 12.9	14	32	60	105	165	250	375	475	800	1000	1200

WILO USA LLC

Tel: 888-945-6872  
Web: [www.wilo-usa.com](http://www.wilo-usa.com)  
Email: [info@wilo-usa.com](mailto:info@wilo-usa.com)

Wilo Canada Inc.

Tel: 866-945-6236  
Web: [www.wilo-canada.com](http://www.wilo-canada.com)  
Email: [info@wilo-canada.com](mailto:info@wilo-canada.com)

Wilo Mexico

Tel: + 52 55 5586 3209  
Web: [www.wilo-mexico.com](http://www.wilo-mexico.com)  
Email: [info@wilo.com.mx](mailto:info@wilo.com.mx)

**wilo**®