

Submittal Data Sheet

Wilco SCP – Horizontal Split Case Pumps

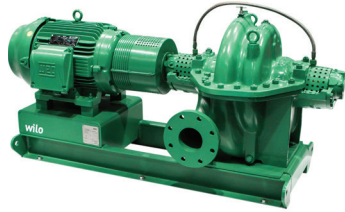

SCP 2½ x 2 x 8½ HA



Project:	
Engineer:	
Contractor:	
Submitted By:	Date:
Approved By:	Date:

Tag #	Model #	Flow (USGPM)	Head (Feet)	HP	Enclosure TEFC/ODP	Frame	Cycle	Phase	Voltage	RPM
	SCP 2½ x 2 x 8½ HA						60 Hz	3		

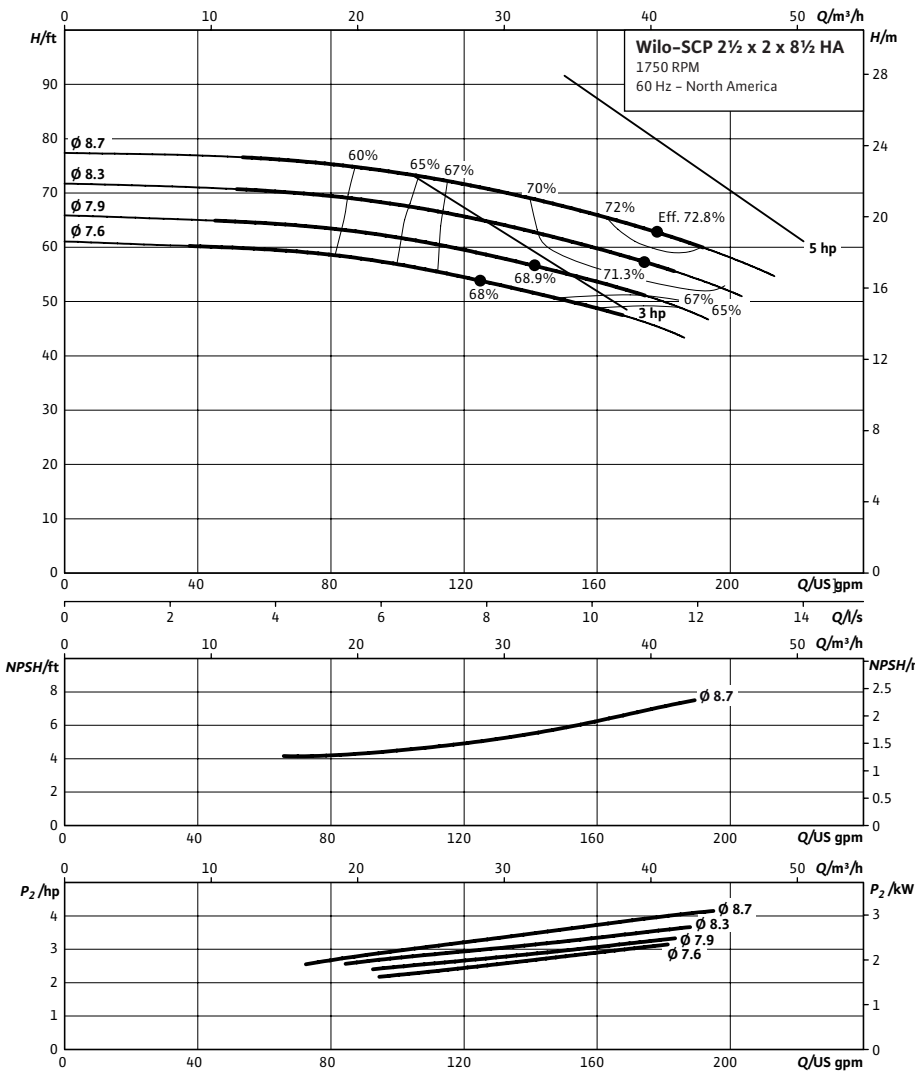

Technical Data

Approved Fluids

- Heating Water
- Cooling and cold water
- Water-Glycol mixtures (for 20–40% glycol and fluid temp ≤ 104°F [40°C])

Fluid Temperature

- Mechanical Seal: 18°F to 250°F (–8°C to 120°C)
- Stuffing Box Packing: 18°F to 220°F (–8°C to 105°C)

Materials of Construction

<input type="checkbox"/> Pump Housing	A48 Class 35
<input type="checkbox"/> Pump Housing (Optional)	Ni-resist BS 3468 Gr 2 / BS 2789 500.1
<input type="checkbox"/> Impeller	BS 84 C83 600
<input type="checkbox"/> Impeller (optional)	A48 Class 35 / BS 84 C83 600
<input type="checkbox"/> Stationary Wear Rings	BS 84 C93 700
<input type="checkbox"/> Pump Shaft	A276 type 410
<input type="checkbox"/> Pump Shaft (optional)	BS 970 316 S16
<input type="checkbox"/> Mechanical Seal	Carbon/silicon carbide/EPDM (E1)
<input type="checkbox"/> Other Mechanical Seals	Avail. on request
<input type="checkbox"/> Additional Spacer Coupling	Avail. on request
<input type="checkbox"/> Other:	

Approval Stamp

Dimensional Drawing

Single Stage Pump

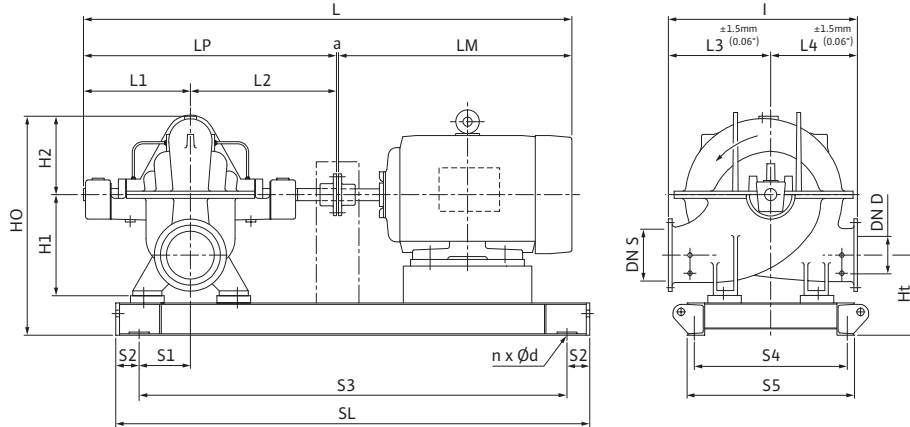

SCP 2½ x 2 x 8½ HA

Dimensions - Inches (mm)

Frame	a	L	I	L1	L2	L3	L4	LM	LP	H1	H2	HO	Ht	n	Ød	S1	S2	S3	S4	S5	SL	P5	P6
182T	.50 (13)	38.94 (989)	13.38 (340)	10.06 (256)	11.81 (300)	7.50 (191)	5.88 (149)	16.50 (419)	21.88 (556)	7.88 (200)	5.63 (143)	18.00 (457)	7.50 (191)	4	.91 (23)	.94 (24)	4.00 (102)	22.75 (578)	9.44 (240)	11.00 (279)	30.75 (781)	-	-
184T	.50 (13)	38.94 (989)	13.38 (340)	10.06 (256)	11.81 (300)	7.50 (191)	5.88 (149)	16.50 (419)	21.88 (556)	7.88 (200)	5.63 (143)	18.00 (457)	7.50 (191)	4	.91 (23)	.94 (24)	4.00 (102)	22.75 (578)	9.44 (240)	11.00 (279)	30.75 (781)	-	-

Flange Dimensions – Suction Side

Dimensions - Inches (mm)

DN S #125	ØD	Ød	Øk	b	n	D2
2½	7.00 (178)	4.13 (105)	5.50 (140)	.88 (22)	4	.75 (19)

Flange Dimensions – Discharge Side

Dimensions - Inches (mm)

DN D 125#	ØD	Ød	Øk	b	n	D2
2	6.00 (152)	3.63 (92)	4.75 (121)	.75 (19)	4	.75 (19)

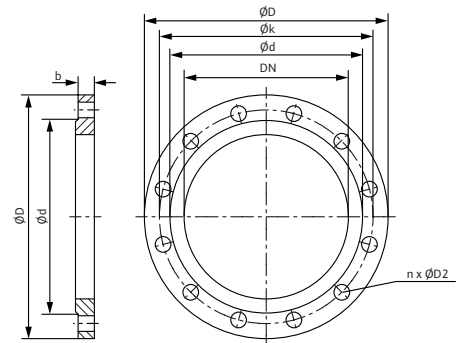

Submittal Data Sheet

Wilco SCP – Horizontal Split Case Pumps



SCP 3 x 2½ x 15 HS

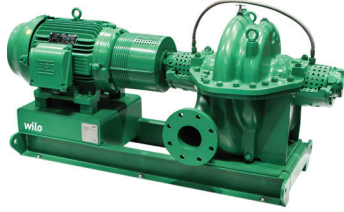

Project:	
Engineer:	
Contractor:	
Submitted By:	Date:
Approved By:	Date:

Tag #	Model #	Flow (USGPM)	Head (Feet)	HP	Enclosure TEFC/ODP	Frame	Cycle	Phase	Voltage	RPM
	SCP 3 x 2½ x 15 HS						60 Hz	3		

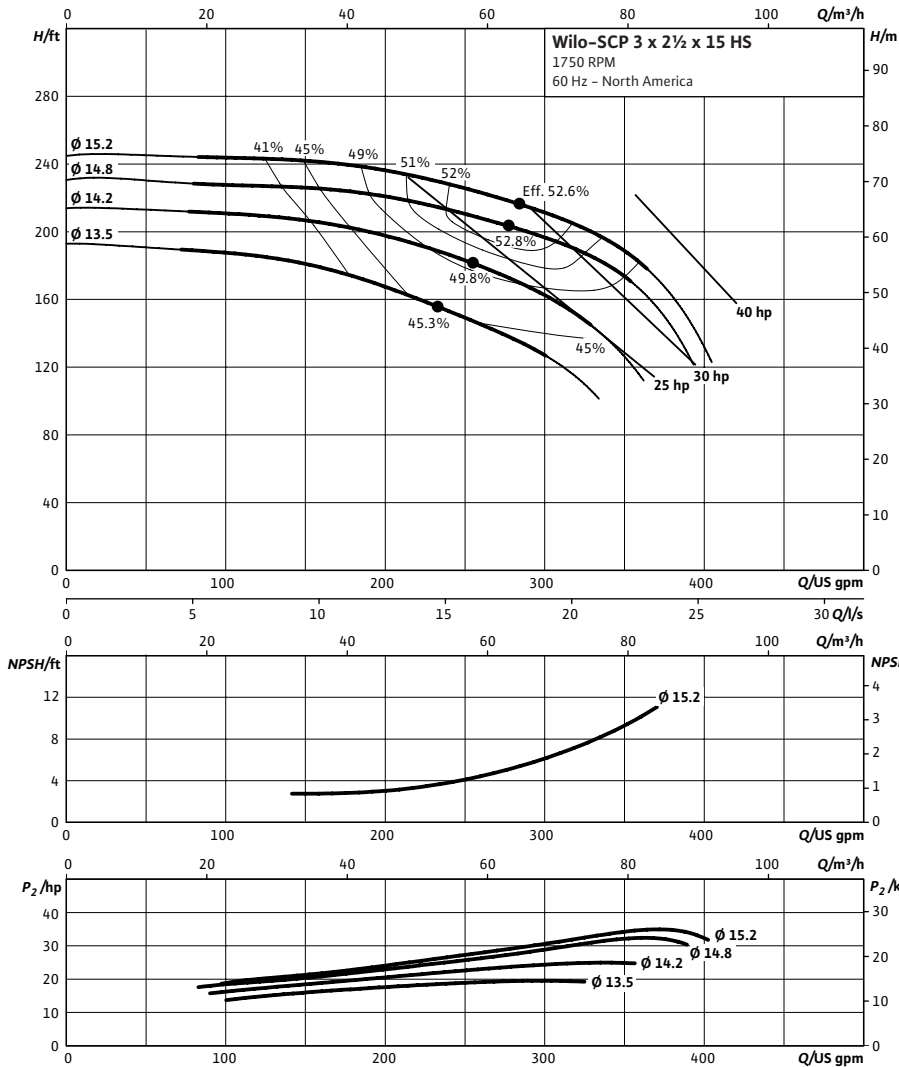

Technical Data

Approved Fluids	
Heating Water	
Cooling and cold water	
Water-Glycol mixtures (for 20-40% glycol and fluid temp ≤ 104°F [40°C])	
Fluid Temperature	
Mechanical Seal	18°F to 250°F (-8°C to 120°C)
Stuffing Box Packing	18°F to 220°F (-8°C to 105°C)

Materials of Construction

<input type="checkbox"/> Pump Housing	A48 Class 35
<input type="checkbox"/> Pump Housing (Optional)	Ni-resist BS 3468 Gr 2 / BS 2789 500.1
<input type="checkbox"/> Impeller	BS 84 C83 600
<input type="checkbox"/> Impeller (optional)	A48 Class 35 / BS 84 C83 600
<input type="checkbox"/> Stationary Wear Rings	BS 84 C93 700
<input type="checkbox"/> Pump Shaft	A276 type 410
<input type="checkbox"/> Pump Shaft (optional)	BS 970 316 S16
<input type="checkbox"/> Mechanical Seal	Carbon/silicon carbide/EPDM (E1)
<input type="checkbox"/> Other Mechanical Seals	Avail. on request
<input type="checkbox"/> Additional Spacer Coupling	Avail. on request
<input type="checkbox"/> Other:	

Approval Stamp

Dimensional Drawing

Single Stage Pump

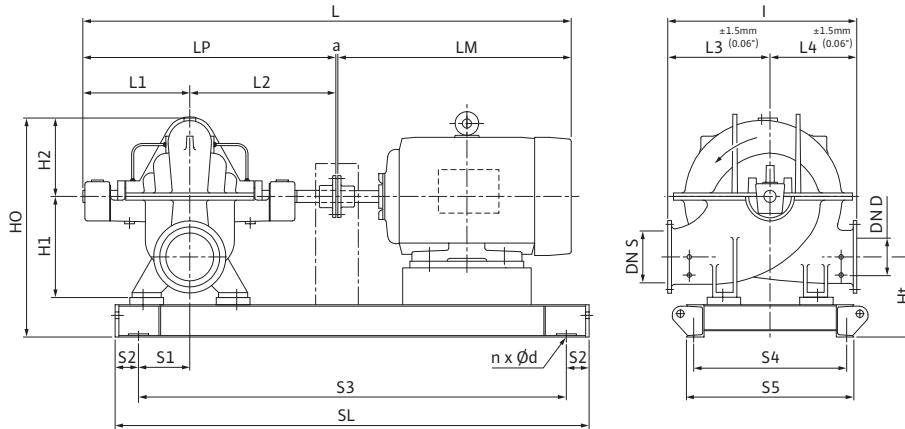

SCP 3 x 2½ x 15 HS

Dimensions - Inches (mm)

Frame	a	L	I	L1	L2	L3	L4	LM	LP	H1	H2	HO	Ht	n	Ød	S1	S2	S3	S4	S5	SL	P5	P6
284T	.50 (13)	53.50 (1359)	21.63 (549)	11.75 (298)	15.31 (389)	11.81 (300)	9.81 (249)	25.94 (656)	27.06 (687)	11.00 (279)	9.06 (230)	24.69 (627)	7.19 (183)	4	.91 (23)	1.69 (43)	4.00 (102)	36.50 (927)	13.06 (331)	14.63 (372)	44.50 (1130)	-	-
286T	.50 (13)	53.50 (1359)	21.63 (549)	11.75 (298)	15.31 (389)	11.81 (300)	9.81 (249)	25.94 (656)	27.06 (687)	11.00 (279)	9.06 (230)	24.69 (627)	7.19 (183)	4	.91 (23)	1.69 (43)	4.00 (102)	36.50 (927)	13.06 (331)	14.63 (372)	44.50 (1130)	-	-
324T	.50 (13)	57.94 (1472)	21.63 (549)	11.75 (298)	15.31 (389)	11.81 (300)	9.81 (249)	25.94 (656)	27.06 (687)	11.00 (279)	9.06 (230)	24.69 (627)	7.19 (183)	4	.91 (23)	1.69 (43)	4.00 (102)	38.88 (988)	15.06 (383)	16.63 (422)	46.88 (1191)	-	-

Flange Dimensions – Suction Side

Dimensions - Inches (mm)

DN S #125	ØD	Ød	Øk	b	n	D2
3	7.50 (191)	5.50 (140)	6.00 (152)	.94 (24)	4	.75 (19)

Flange Dimensions – Discharge Side

Dimensions - Inches (mm)

DN D 125#	ØD	Ød	Øk	b	n	D2
2½	7.00 (178)	4.13 (105)	5.50 (140)	.88 (22)	4	.75 (19)

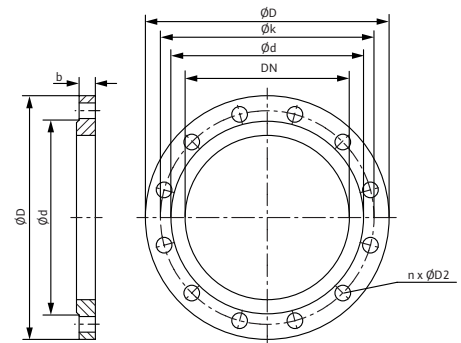

Submittal Data Sheet

Wilo SCP – Horizontal Split Case Pumps

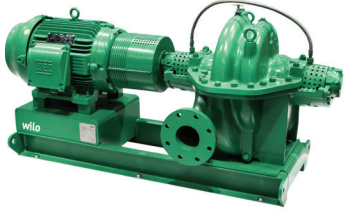

SCP 3 x 2 x 7 HA

		Project:								
		Engineer:								
		Contractor:								
		Submitted By:						Date:		
		Approved By:						Date:		
Tag #	Model #	Flow (USGPM)	Head (Feet)	HP	Enclosure TEFC/ODP	Frame	Cycle	Phase	Voltage	RPM
	SCP 3 x 2 x 7 HA						60 Hz	3		

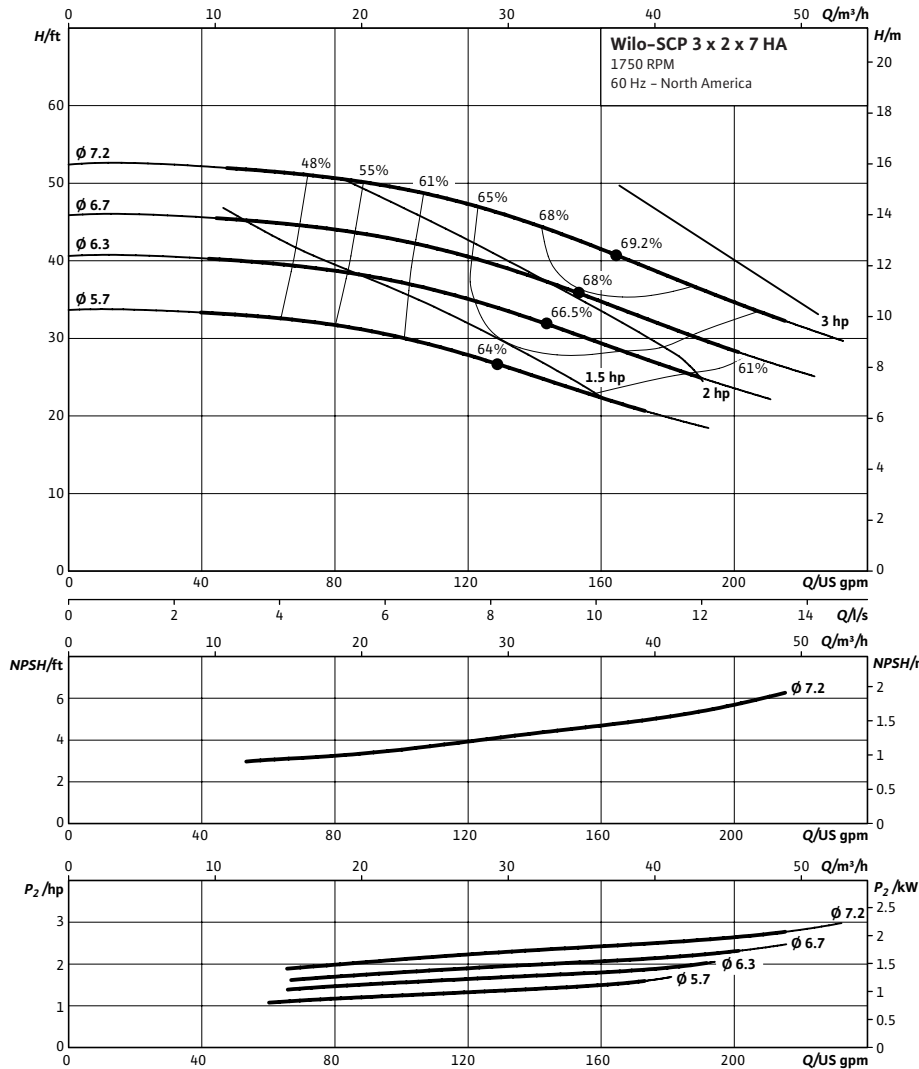

Technical Data

Approved Fluids	
Heating Water	
Cooling and cold water	
Water-Glycol mixtures (for 20–40% glycol and fluid temp ≤ 104°F [40°C])	
Fluid Temperature	
Mechanical Seal	18°F to 250°F (–8°C to 120°C)
Stuffing Box Packing	18°F to 220°F (–8°C to 105°C)

Materials of Construction

<input type="checkbox"/> Pump Housing	A48 Class 35
<input type="checkbox"/> Pump Housing (Optional)	Ni-resist BS 3468 Gr 2 / BS 2789 500.1
<input type="checkbox"/> Impeller	BS 84 C83 600
<input type="checkbox"/> Impeller (optional)	A48 Class 35 / BS 84 C83 600
<input type="checkbox"/> Stationary Wear Rings	BS 84 C93 700
<input type="checkbox"/> Pump Shaft	A276 type 410
<input type="checkbox"/> Pump Shaft (optional)	BS 970 316 S16
<input type="checkbox"/> Mechanical Seal	Carbon/silicon carbide/EPDM (E1)
<input type="checkbox"/> Other Mechanical Seals	Avail. on request
<input type="checkbox"/> Additional Spacer Coupling	Avail. on request
<input type="checkbox"/> Other:	

Approval Stamp

Dimensional Drawing

Single Stage Pump

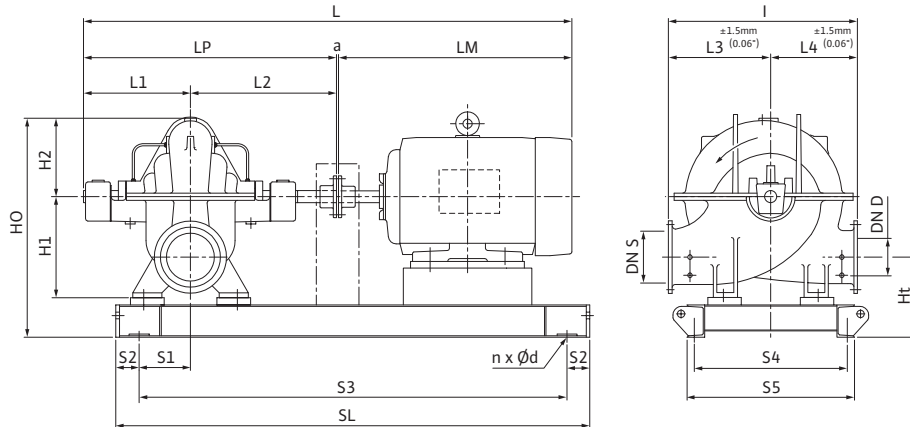

SCP 3 x 2 x 7 HA

Dimensions - Inches (mm)

Frame	a	L	I	L1	L2	L3	L4	LM	LP	H1	H2	HO	Ht	n	Ød	S1	S2	S3	S4	S5	SL	P5	P6
145T	.50 (13)	40.19 (1021)	14.56 (370)	11.88 (302)	14.50 (368)	7.88 (200)	11.69 (170)	13.31 (338)	26.38 (670)	7.88 (200)	5.31 (135)	17.88 (454)	7.94 (202)	4	.91 (23)	.94 (24)	4.00 (102)	23.88 (606)	8.69 (221)	10.25 (260)	31.88 (810)	-	-
182T	.50 (13)	43.38 (1102)	14.56 (370)	11.88 (302)	14.50 (368)	7.88 (200)	11.69 (170)	16.50 (419)	26.38 (670)	7.88 (200)	5.31 (135)	17.88 (454)	7.94 (202)	4	.91 (23)	.94 (24)	4.00 (102)	25.44 (646)	9.44 (240)	11.00 (279)	33.44 (849)	-	-
184T	.50 (13)	43.44 (1104)	14.56 (370)	11.88 (302)	14.50 (368)	7.88 (200)	11.69 (170)	16.56 (421)	26.38 (670)	7.88 (200)	5.31 (135)	17.88 (454)	7.94 (202)	4	.91 (23)	.94 (24)	4.00 (102)	25.44 (646)	9.44 (240)	11.00 (279)	33.44 (849)	-	-

Flange Dimensions – Suction Side

Dimensions - Inches (mm)

DN S #125	ØD	Ød	Øk	b	n	D2
3	7.50 (191)	5.50 (140)	6.00 (152)	.94 (24)	4	.75 (19)

Flange Dimensions – Discharge Side

Dimensions - Inches (mm)

DN D 125#	ØD	Ød	Øk	b	n	D2
2	6.00 (152)	3.63 (92)	4.75 (121)	.75 (19)	4	.75 (19)

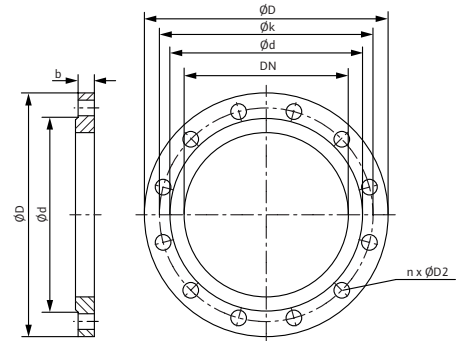

Submittal Data Sheet

Wilo SCP – Horizontal Split Case Pumps



SCP 3 x 2 x 13 DS

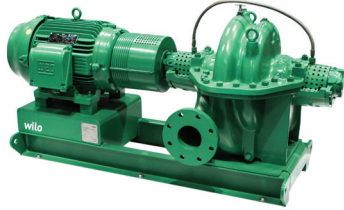

Project:	
Engineer:	
Contractor:	
Submitted By:	Date:
Approved By:	Date:

Tag #	Model #	Flow (USGPM)	Head (Feet)	HP	Enclosure TEFC/ODP	Frame	Cycle	Phase	Voltage	RPM
	SCP 3 x 2 x 13 DS						60 Hz	3		

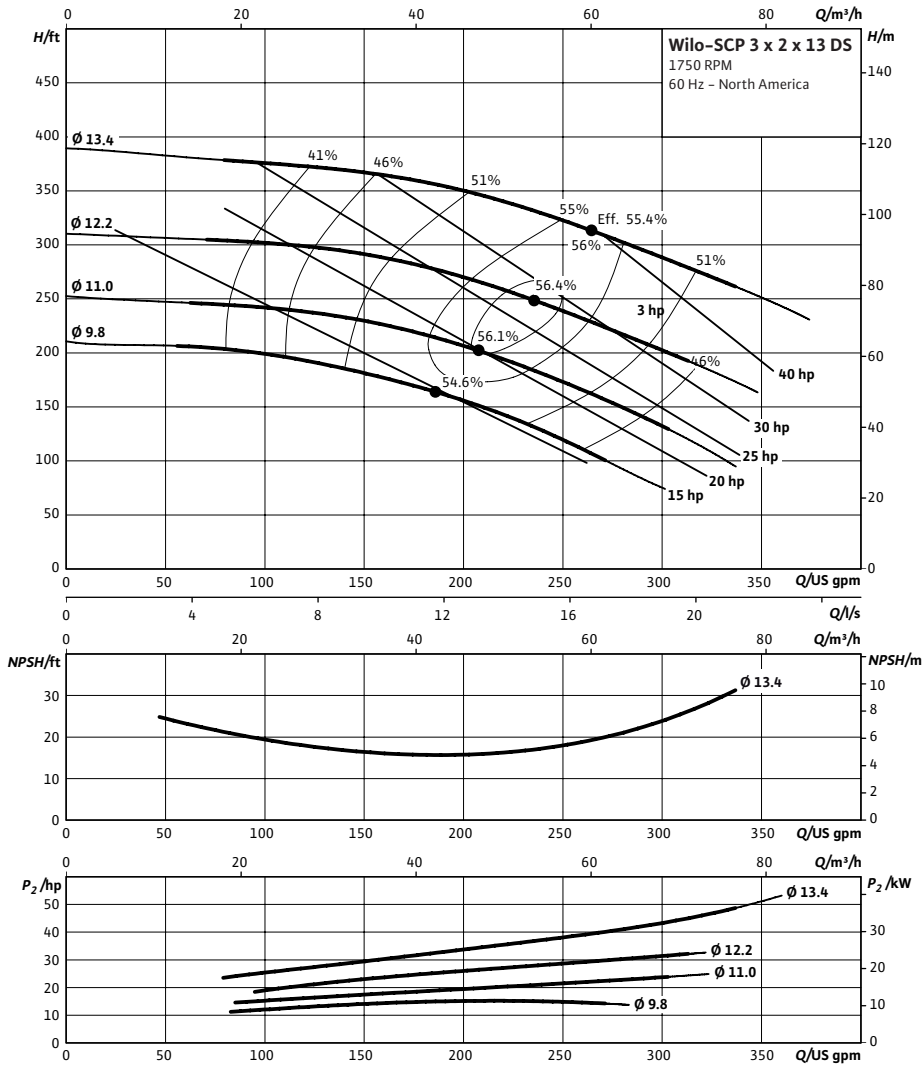

Technical Data

Approved Fluids

Heating Water
Cooling and cold water

Water-Glycol mixtures (for 20–40% glycol and fluid temp ≤ 104°F [40°C])

Fluid Temperature

Mechanical Seal 18°F to 250°F (–8°C to 120°C)
Stuffing Box Packing 18°F to 220°F (–8°C to 105°C)

Materials of Construction

<input type="checkbox"/>	Pump Housing	A48 Class 35
<input type="checkbox"/>	Pump Housing (Optional)	Ni-resist BS 3468 Gr 2 / BS 2789 500.1
<input type="checkbox"/>	Impeller	BS 84 C83 600
<input type="checkbox"/>	Impeller (optional)	A48 Class 35 / BS 84 C83 600
<input type="checkbox"/>	Stationary Wear Rings	BS 84 C93 700
<input type="checkbox"/>	Pump Shaft	A276 type 410
<input type="checkbox"/>	Pump Shaft (optional)	BS 970 316 S16
<input type="checkbox"/>	Mechanical Seal	Carbon/silicon carbide/EPDM (E1)
<input type="checkbox"/>	Other Mechanical Seals	Avail. on request
<input type="checkbox"/>	Additional Spacer Coupling	Avail. on request
<input type="checkbox"/>	Other:	

Approval Stamp

Dimensional Drawing

Dual Stage Pump

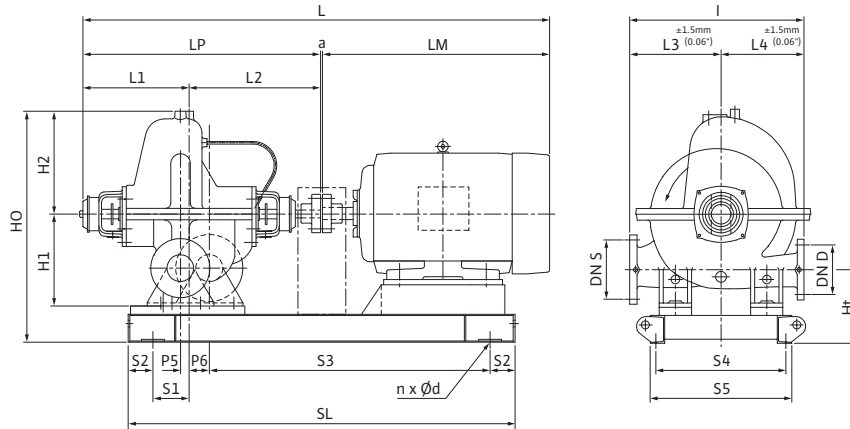

SCP 3 x 2 x 13 DS

Dimensions - Inches (mm)

Frame	a	L	l	L1	L2	L3	L4	LM	LP	H1	H2	HO	Ht	n	Ød	S1	S2	S3	S4	S5	SL	P5	P6
254T	.50 (13)	53.00 (1346)	20.25 (514)	15.00 (381)	16.44 (418)	11.81 (300)	8.44 (214)	21.06 (535)	31.44 (799)	11.44 (291)	8.88 (226)	25.88 (657)	9.81 (249)	4	.91 (23)	2.88 (73)	4.00 (102)	34.94 (887)	11.31 (287)	13.63 (346)	42.94 (1091)	1.69 (43)	4.63 (118)
256T	.50 (13)	55.06 (1399)	20.25 (514)	15.00 (381)	16.44 (418)	11.81 (300)	8.44 (214)	21.06 (535)	31.44 (799)	11.44 (291)	8.88 (226)	25.88 (657)	9.81 (249)	4	.91 (23)	2.88 (73)	4.00 (102)	36.69 (932)	11.31 (287)	13.63 (346)	44.69 (1135)	1.69 (43)	4.63 (118)
284T	.50 (13)	57.88 (1470)	20.25 (514)	15.00 (381)	16.44 (418)	11.81 (300)	8.44 (214)	21.06 (535)	31.44 (799)	11.44 (291)	8.88 (226)	25.88 (657)	9.81 (249)	4	.91 (23)	2.88 (73)	4.00 (102)	38.81 (986)	12.31 (313)	14.63 (371)	46.81 (1189)	1.69 (43)	4.63 (118)
286T	.50 (13)	57.88 (1470)	20.25 (514)	15.00 (381)	16.44 (418)	11.81 (300)	8.44 (214)	21.06 (535)	31.44 (799)	11.44 (291)	8.88 (226)	25.88 (657)	9.81 (249)	4	.91 (23)	2.88 (73)	4.00 (102)	39.81 (986)	12.31 (313)	14.63 (371)	46.81 (1189)	1.69 (43)	4.63 (118)
324T	.50 (13)	62.31 (1583)	20.25 (514)	15.00 (381)	16.44 (418)	11.81 (300)	8.44 (214)	21.06 (535)	31.44 (799)	11.44 (291)	8.88 (226)	25.88 (657)	9.81 (249)	4	.91 (23)	2.88 (73)	4.00 (102)	41.19 (1046)	14.31 (364)	16.63 (422)	49.19 (1251)	1.69 (43)	4.63 (118)
326T	.50 (13)	62.31 (1583)	20.25 (514)	15.00 (381)	16.44 (418)	11.81 (300)	8.44 (214)	21.06 (535)	31.44 (799)	11.44 (291)	8.88 (226)	25.88 (657)	9.81 (249)	4	.91 (23)	2.88 (73)	4.00 (102)	41.19 (1046)	14.31 (364)	16.63 (422)	49.19 (1251)	1.69 (43)	4.63 (118)

Flange Dimensions – Suction Side

Dimensions - Inches (mm)

DN S #125	ØD	Ød	Øk	b	n	D2
3	7.50 (191)	5.50 (140)	6.00 (152)	.94 (24)	4	.75 (19)

Flange Dimensions – Discharge Side

Dimensions - Inches (mm)

DN D 125#	ØD	Ød	Øk	b	n	D2
2	6.00 (152)	3.63 (92)	4.75 (121)	.75 (19)	4	.75 (19)

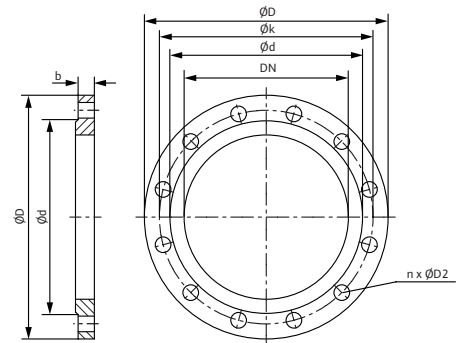

Submittal Data Sheet

Wilo SCP – Horizontal Split Case Pumps



SCP 3 x 2 x 13 HA

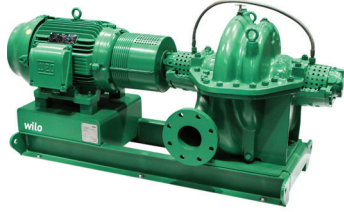

Project:	
Engineer:	
Contractor:	
Submitted By:	Date:
Approved By:	Date:

Tag #	Model #	Flow (USGPM)	Head (Feet)	HP	Enclosure TEFC/ODP	Frame	Cycle	Phase	Voltage	RPM
	SCP 3 x 2 x 13 HA						60 Hz	3		

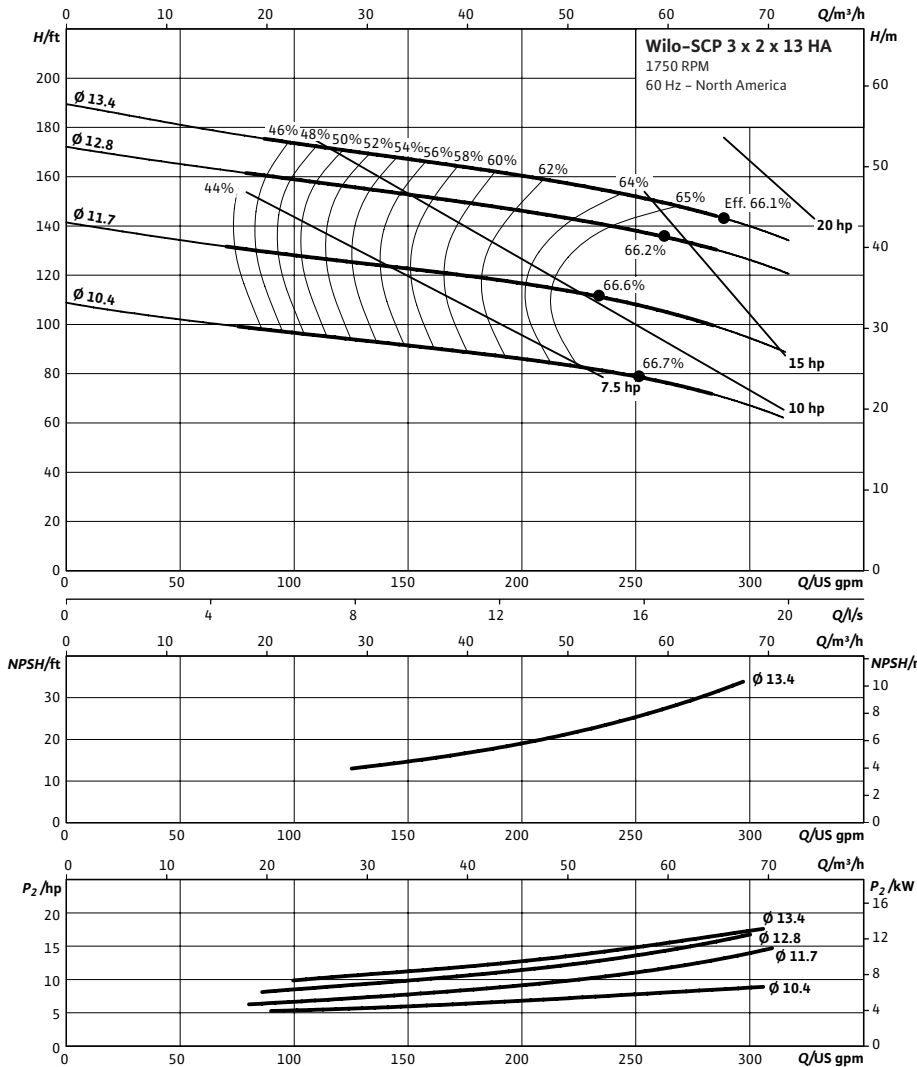

Technical Data

Approved Fluids

- Heating Water
- Cooling and cold water
- Water-Glycol mixtures (for 20-40% glycol and fluid temp ≤ 104°F [40°C])

Fluid Temperature

- Mechanical Seal: 18°F to 250°F (-8°C to 120°C)
- Stuffing Box Packing: 18°F to 220°F (-8°C to 105°C)

Materials of Construction

<input type="checkbox"/> Pump Housing	A48 Class 35
<input type="checkbox"/> Pump Housing (Optional)	Ni-resist BS 3468 Gr 2 / BS 2789 500.1
<input type="checkbox"/> Impeller	BS 84 C83 600
<input type="checkbox"/> Impeller (optional)	A48 Class 35 / BS 84 C83 600
<input type="checkbox"/> Stationary Wear Rings	BS 84 C93 700
<input type="checkbox"/> Pump Shaft	A276 type 410
<input type="checkbox"/> Pump Shaft (optional)	BS 970 316 S16
<input type="checkbox"/> Mechanical Seal	Carbon/silicon carbide/EPDM (E1)
<input type="checkbox"/> Other Mechanical Seals	Avail. on request
<input type="checkbox"/> Additional Spacer Coupling	Avail. on request
<input type="checkbox"/> Other:	

Approval Stamp

Dimensional Drawing

Single Stage Pump

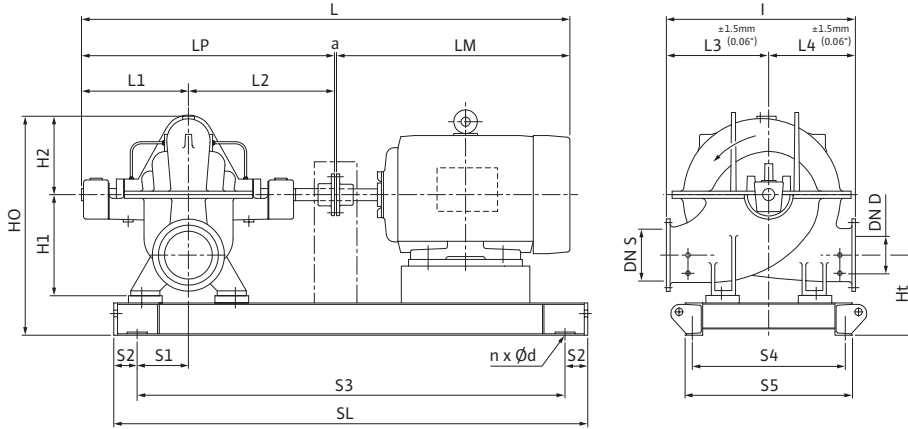

SCP 3 x 2 x 13 HA

Dimensions - Inches (mm)

Frame	a	L	I	L1	L2	L3	L4	LM	LP	H1	H2	HO	Ht	n	Ød	S1	S2	S3	S4	S5	SL	P5	P6
184T	.50 (13)	44.69 (1135)	18.88 (480)	12.50 (318)	15.19 (386)	10.25 (260)	8.56 (218)	16.56 (421)	27.63 (702)	9.81 (249)	8.38 (213)	22.88 (581)	6.94 (176)	4	.91 (23)	1.94 (49)	4.00 (102)	26.44 (672)	10.25 (260)	11.88 (302)	34.44 (875)	-	-
213T	.50 (13)	46.00 (1168)	18.88 (480)	12.50 (318)	15.19 (386)	10.25 (260)	8.56 (218)	17.88 (454)	27.63 (702)	9.81 (249)	8.38 (213)	22.88 (581)	6.94 (176)	4	.91 (23)	1.94 (49)	4.00 (102)	29.38 (746)	10.31 (262)	11.88 (302)	37.38 (949)	-	-
215T	.50 (13)	47.13 (1197)	18.88 (480)	12.50 (318)	15.19 (386)	10.25 (260)	8.56 (218)	19.00 (483)	27.63 (702)	9.81 (249)	8.38 (213)	22.88 (581)	6.94 (176)	4	.91 (23)	1.94 (49)	4.00 (102)	29.38 (746)	10.31 (262)	11.88 (302)	37.38 (949)	-	-
254T	.50 (13)	49.19 (1249)	18.88 (480)	12.50 (318)	15.19 (386)	10.25 (260)	8.56 (218)	21.06 (535)	27.63 (702)	9.81 (249)	8.38 (213)	22.88 (581)	6.94 (176)	4	.91 (23)	1.94 (49)	4.00 (102)	32.06 (814)	12.06 (306)	13.63 (346)	40.06 (1018)	-	-
256T	.50 (13)	51.31 (1303)	18.88 (480)	12.50 (318)	15.19 (386)	10.25 (260)	8.56 (218)	23.19 (589)	27.63 (702)	9.81 (249)	8.38 (213)	22.88 (581)	6.94 (176)	4	.91 (23)	1.94 (49)	4.00 (102)	33.81 (859)	12.06 (306)	13.63 (346)	41.81 (1062)	-	-

Flange Dimensions - Suction Side

Dimensions - Inches (mm)

DN S #125	ØD	Ød	Øk	b	n	D2
3	7.50 (191)	5.50 (140)	6.00 (152)	.94 (24)	4	.75 (19)

Flange Dimensions - Discharge Side

Dimensions - Inches (mm)

DN D 125#	ØD	Ød	Øk	b	n	D2
2	6.00 (152)	3.63 (92)	4.75 (121)	.75 (19)	4	.75 (19)

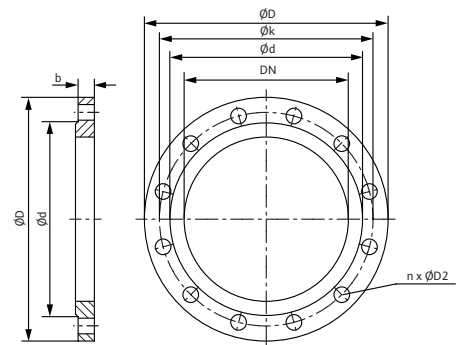

Submittal Data Sheet

Wilo SCP – Horizontal Split Case Pumps



SCP 4 x 3 x 7½ HA

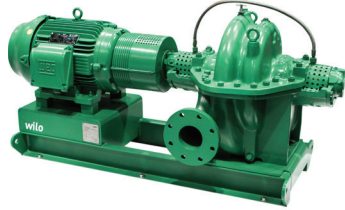

Project:	
Engineer:	
Contractor:	
Submitted By:	Date:
Approved By:	Date:

Tag #	Model #	Flow (USGPM)	Head (Feet)	HP	Enclosure TEFC/ODP	Frame	Cycle	Phase	Voltage	RPM
	SCP 4 x 3 x 7½ HA						60 Hz	3		

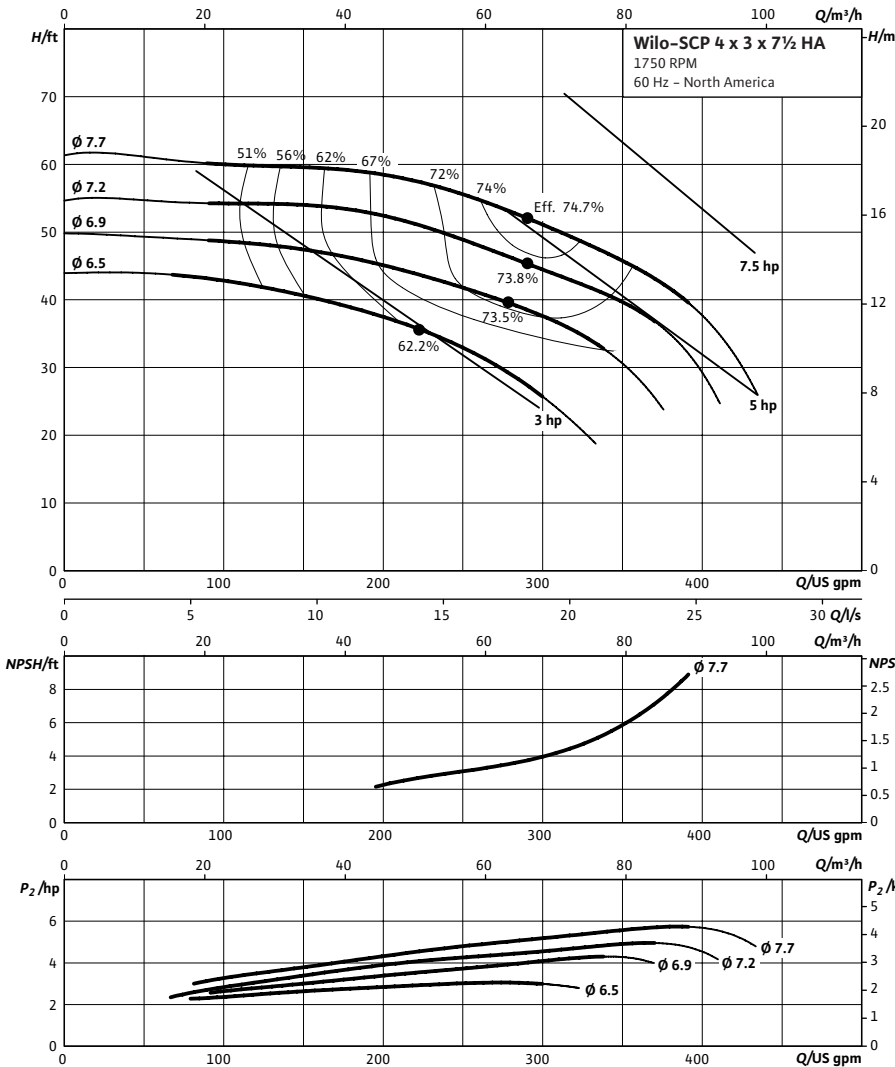

Technical Data

Approved Fluids

Heating Water
Cooling and cold water

Water-Glycol mixtures (for 20–40% glycol and fluid temp ≤ 104°F [40°C])

Fluid Temperature

Mechanical Seal 18°F to 250°F (–8°C to 120°C)
Stuffing Box Packing 18°F to 220°F (–8°C to 105°C)

Materials of Construction

<input type="checkbox"/>	Pump Housing	A48 Class 35
<input type="checkbox"/>	Pump Housing (Optional)	Ni-resist BS 3468 Gr 2 / BS 2789 500.1
<input type="checkbox"/>	Impeller	BS 84 C83 600
<input type="checkbox"/>	Impeller (optional)	A48 Class 35 / BS 84 C83 600
<input type="checkbox"/>	Stationary Wear Rings	BS 84 C93 700
<input type="checkbox"/>	Pump Shaft	A276 type 410
<input type="checkbox"/>	Pump Shaft (optional)	BS 970 316 S16
<input type="checkbox"/>	Mechanical Seal	Carbon/silicon carbide/EPDM (E1)
<input type="checkbox"/>	Other Mechanical Seals	Avail. on request
<input type="checkbox"/>	Additional Spacer Coupling	Avail. on request
<input type="checkbox"/>	Other:	

Approval Stamp

Dimensional Drawing

Single Stage Pump

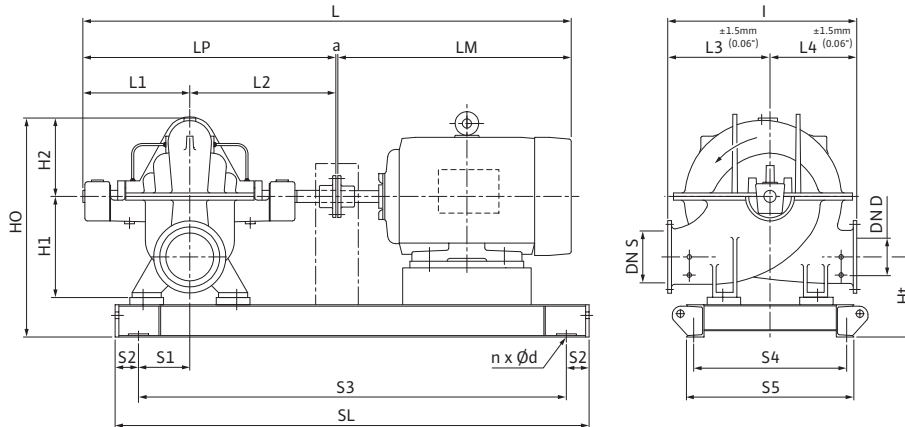

SCP 4 x 3 x 7½ HA

Dimensions - Inches (mm)

Frame	a	L	I	L1	L2	L3	L4	LM	LP	H1	H2	HO	Ht	n	Ød	S1	S2	S3	S4	S5	SL	P5	P6
182T	.50 (13)	45.75 (1162)	16.31 (414)	13.06 (332)	15.69 (399)	8.88 (226)	7.50 (191)	16.50 (419)	28.75 (730)	9.81 (249)	6.13 (156)	20.63 (524)	9.19 (233)	4	.91 (23)	1.69 (43)	4.00 (102)	27.00 (686)	10.25 (260)	11.88 (302)	35.0 (889)	-	-
184T	.50 (13)	45.75 (1162)	16.31 (414)	13.06 (332)	15.69 (399)	8.88 (226)	7.50 (191)	16.56 (421)	28.75 (730)	9.81 (249)	6.13 (156)	20.63 (524)	9.19 (233)	4	.91 (23)	1.69 (43)	4.00 (102)	27.00 (686)	10.25 (260)	11.88 (302)	35.0 (889)	-	-
213T	.50 (13)	47.13 (1197)	16.31 (414)	13.06 (332)	15.69 (399)	8.88 (226)	7.50 (191)	17.88 (454)	28.75 (730)	9.81 (249)	6.13 (156)	20.63 (524)	9.19 (233)	4	.91 (23)	1.69 (43)	4.00 (102)	29.88 (759)	10.31 (262)	11.88 (302)	37.88 (962)	-	-

Flange Dimensions – Suction Side

Dimensions - Inches (mm)

DN S #125	ØD	Ød	Øk	b	n	D2
4	9.00 (229)	6.19 (157)	7.50 (191)	.94 (24)	8	.75 (19)

Flange Dimensions – Discharge Side

Dimensions - Inches (mm)

DN D 125#	ØD	Ød	Øk	b	n	D2
3	7.50 (191)	5.50 (140)	6.00 (152)	.94 (24)	4	.75 (19)

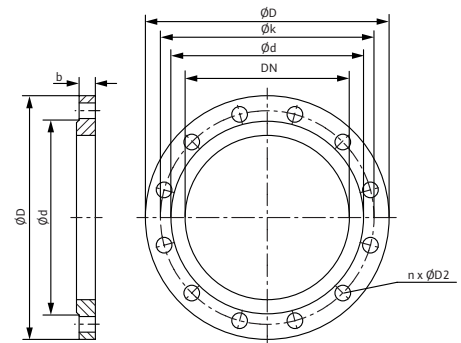

Submittal Data Sheet

Wilo SCP – Horizontal Split Case Pumps



SCP 4 x 3 x 9 HA

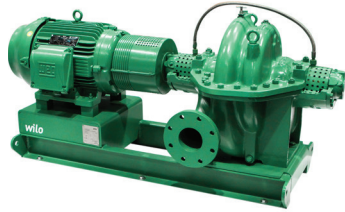

Project:	
Engineer:	
Contractor:	
Submitted By:	Date:
Approved By:	Date:

Tag #	Model #	Flow (USGPM)	Head (Feet)	HP	Enclosure TEFC/ODP	Frame	Cycle	Phase	Voltage	RPM
	SCP 4 x 3 x 9 HA						60 Hz	3		

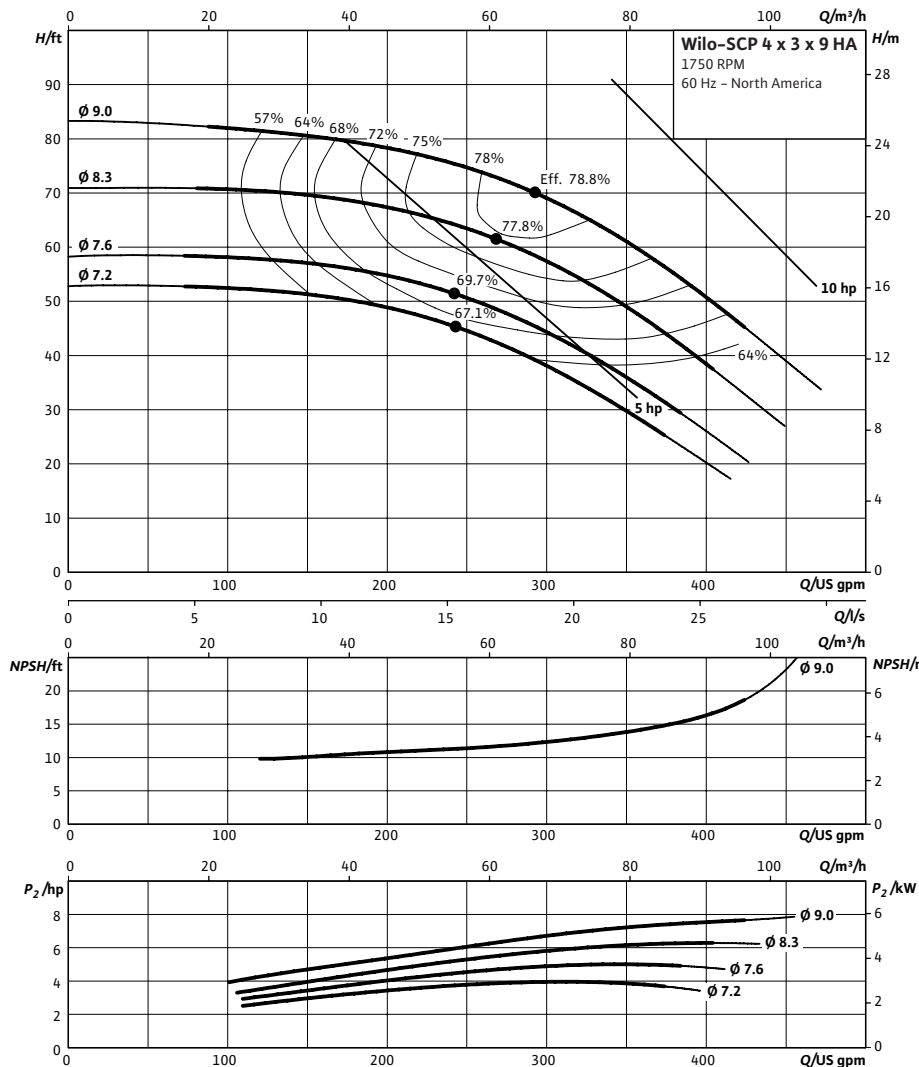

Technical Data

Approved Fluids	
Heating Water	
Cooling and cold water	
Water-Glycol mixtures (for 20-40% glycol and fluid temp ≤ 104°F [40°C])	
Fluid Temperature	
Mechanical Seal	18°F to 250°F (-8°C to 120°C)
Stuffing Box Packing	18°F to 220°F (-8°C to 105°C)

Materials of Construction

<input type="checkbox"/> Pump Housing	A48 Class 35
<input type="checkbox"/> Pump Housing (Optional)	Ni-resist BS 3468 Gr 2 / BS 2789 500.1
<input type="checkbox"/> Impeller	BS 84 C83 600
<input type="checkbox"/> Impeller (optional)	A48 Class 35 / BS 84 C83 600
<input type="checkbox"/> Stationary Wear Rings	BS 84 C93 700
<input type="checkbox"/> Pump Shaft	A276 type 410
<input type="checkbox"/> Pump Shaft (optional)	BS 970 316 S16
<input type="checkbox"/> Mechanical Seal	Carbon/silicon carbide/EPDM (E1)
<input type="checkbox"/> Other Mechanical Seals	Avail. on request
<input type="checkbox"/> Additional Spacer Coupling	Avail. on request
<input type="checkbox"/> Other:	

Approval Stamp

Dimensional Drawing

Single Stage Pump

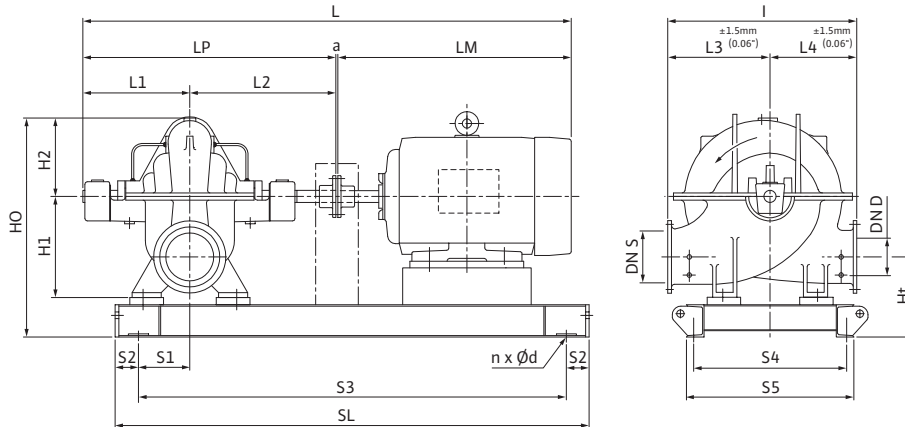

SCP 4 x 3 x 9 HA

Dimensions - Inches (mm)

Frame	a	L	I	L1	L2	L3	L4	LM	LP	H1	H2	HO	Ht	n	Ød	S1	S2	S3	S4	S5	SL	P5	P6
184T	.50 (13)	46.38 (1178)	16.31 (414)	13.63 (346)	15.69 (398)	8.88 (226)	7.50 (191)	16.56 (421)	29.38 (746)	9.81 (249)	6.50 (165)	21.00 (533)	8.75 (222)	4	.91 (23)	1.69 (43)	4.00 (102)	27.00 (686)	10.25 (260)	11.88 (302)	35.0 (889)	-	-
213T	.50 (13)	47.75 (1213)	16.31 (414)	13.63 (346)	15.69 (398)	8.88 (226)	7.50 (191)	17.88 (454)	29.38 (746)	9.81 (249)	6.50 (165)	21.00 (533)	8.75 (222)	4	.91 (23)	1.69 (43)	4.00 (102)	29.88 (759)	10.31 (260)	11.88 (302)	37.88 (962)	-	-
215T	.50 (13)	48.88 (1242)	16.31 (414)	13.63 (346)	15.69 (398)	8.88 (226)	7.50 (191)	19.00 (483)	29.38 (746)	9.81 (249)	6.50 (165)	21.00 (533)	8.75 (222)	4	.91 (23)	1.69 (43)	4.00 (102)	29.88 (759)	10.31 (260)	11.88 (302)	37.88 (962)	-	-

Flange Dimensions – Suction Side

Dimensions - Inches (mm)

DN S #125	ØD	Ød	Øk	b	n	D2
4	9.00 (229)	6.19 (157)	7.50 (191)	.94 (24)	8	.75 (19)

Flange Dimensions – Discharge Side

Dimensions - Inches (mm)

DN D 125#	ØD	Ød	Øk	b	n	D2
3	7.50 (191)	5.50 (140)	6.00 (152)	.94 (24)	4	.75 (19)

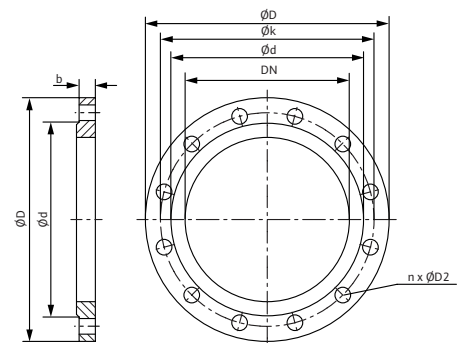

Submittal Data Sheet

Wilo SCP – Horizontal Split Case Pumps



SCP 4 x 3 x 13 HA

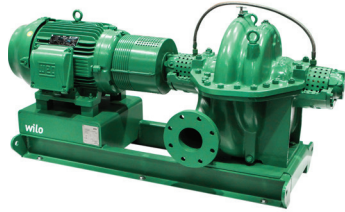

Project:	
Engineer:	
Contractor:	
Submitted By:	Date:
Approved By:	Date:

Tag #	Model #	Flow (USGPM)	Head (Feet)	HP	Enclosure TEFC/ODP	Frame	Cycle	Phase	Voltage	RPM
	SCP 4 x 3 x 13 HA						60 Hz	3		

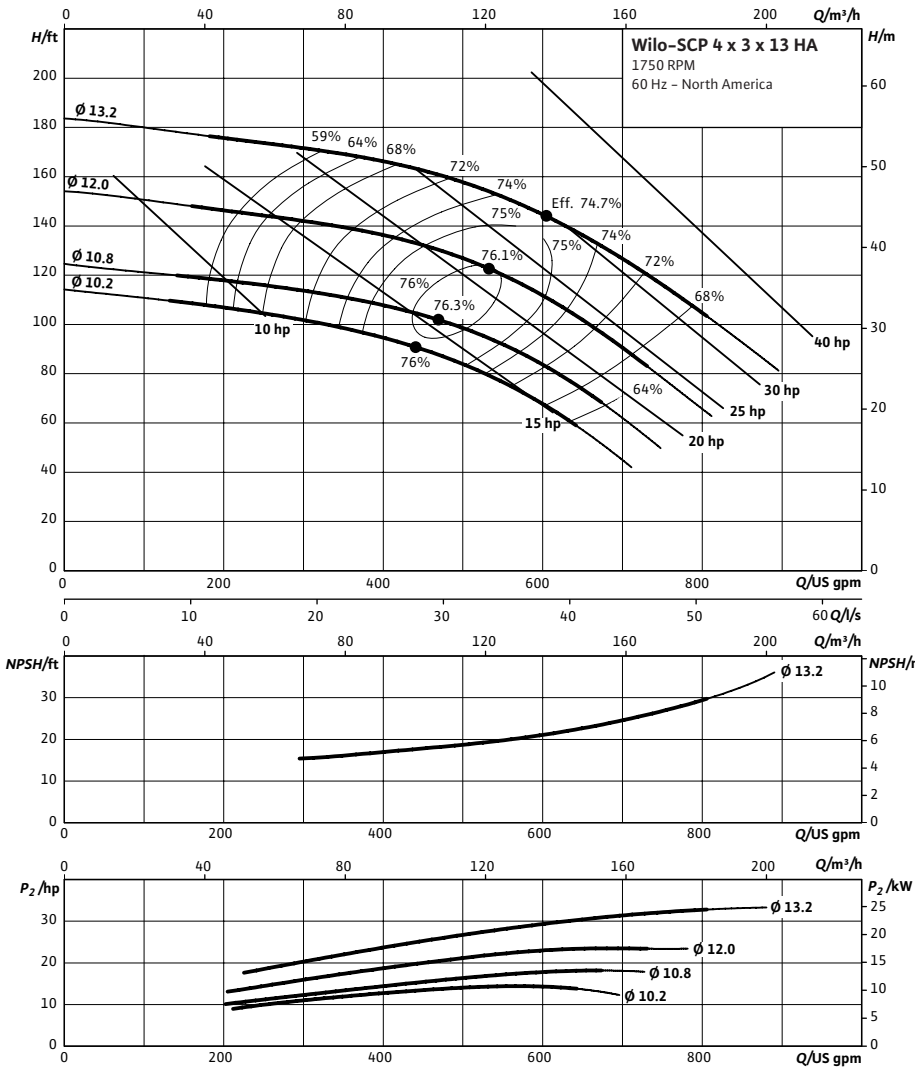

Technical Data

Approved Fluids

- Heating Water
- Cooling and cold water
- Water-Glycol mixtures (for 20-40% glycol and fluid temp ≤ 104°F [40°C])

Fluid Temperature

- Mechanical Seal: 18°F to 250°F (-8°C to 120°C)
- Stuffing Box Packing: 18°F to 220°F (-8°C to 105°C)

Materials of Construction

<input type="checkbox"/>	Pump Housing	A48 Class 35
<input type="checkbox"/>	Pump Housing (Optional)	Ni-resist BS 3468 Gr 2 / BS 2789 500.1
<input type="checkbox"/>	Impeller	BS 84 C83 600
<input type="checkbox"/>	Impeller (optional)	A48 Class 35 / BS 84 C83 600
<input type="checkbox"/>	Stationary Wear Rings	BS 84 C93 700
<input type="checkbox"/>	Pump Shaft	A276 type 410
<input type="checkbox"/>	Pump Shaft (optional)	BS 970 316 S16
<input type="checkbox"/>	Mechanical Seal	Carbon/silicon carbide/EPDM (E1)
<input type="checkbox"/>	Other Mechanical Seals	Avail. on request
<input type="checkbox"/>	Additional Spacer Coupling	Avail. on request
<input type="checkbox"/>	Other:	

Approval Stamp

Dimensional Drawing

Single Stage Pump

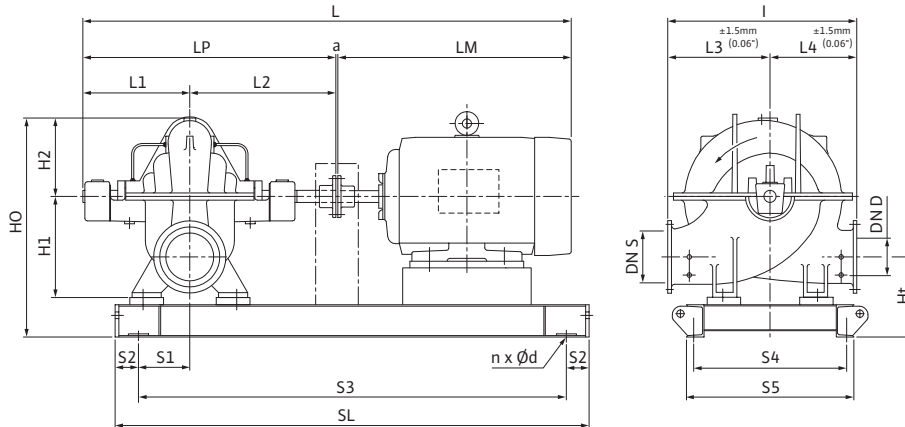

SCP 4 x 3 x 13 HA

Dimensions - Inches (mm)																							
Frame	a	L	I	L1	L2	L3	L4	LM	LP	H1	H2	HO	Ht	n	Ød	S1	S2	S3	S4	S5	SL	P5	P6
215T	.50 (13)	48.88 (1242)	19.88 (505)	13.63 (346)	15.69 (398)	10.81 (275)	9.06 (230)	19.00 (483)	29.38 (746)	11.81 (300)	8.88 (226)	25.31 (643)	8.56 (217)	4	.91 (23)	1.69 (43)	4.00 (102)	29.88 (759)	10.31 (262)	11.88 (302)	37.88 (962)	-	-
254T	.50 (13)	50.94 (1294)	19.88 (505)	13.63 (346)	15.69 (398)	10.81 (275)	9.06 (230)	21.06 (535)	29.38 (746)	11.81 (300)	8.88 (226)	25.31 (643)	8.56 (217)	4	.91 (23)	1.69 (43)	4.00 (102)	32.63 (829)	12.06 (306)	13.63 (346)	40.63 (1032)	-	-
256T	.50 (13)	53.00 (1346)	19.88 (505)	13.63 (346)	15.69 (398)	10.81 (275)	9.06 (230)	23.19 (589)	29.38 (746)	11.81 (300)	8.88 (226)	25.31 (643)	8.56 (217)	4	.91 (23)	1.69 (43)	4.00 (102)	34.38 (873)	12.06 (306)	13.63 (346)	42.38 (1076)	-	-
284T	.50 (13)	55.81 (1418)	19.88 (505)	13.63 (346)	15.69 (398)	10.81 (275)	9.06 (230)	25.94 (689)	29.38 (746)	11.81 (300)	8.88 (226)	25.31 (643)	8.56 (217)	4	.91 (23)	1.69 (43)	4.00 (102)	36.50 (927)	13.06 (332)	14.63 (372)	44.50 (1130)	-	-
286T	.50 (13)	55.81 (1418)	19.88 (505)	13.63 (346)	15.69 (398)	10.81 (275)	9.06 (230)	25.94 (689)	29.38 (746)	11.81 (300)	8.88 (226)	25.31 (643)	8.56 (217)	4	.91 (23)	1.69 (43)	4.00 (102)	36.50 (927)	13.06 (332)	14.63 (372)	44.50 (1130)	-	-

Flange Dimensions – Suction Side

Dimensions - Inches (mm)						
DN S #125	ØD	Ød	Øk	b	n	D2
4	9.00 (229)	6.19 (157)	7.50 (191)	.94 (24)	8	.75 (19)

Flange Dimensions – Discharge Side

Dimensions - Inches (mm)						
DN D 125#	ØD	Ød	Øk	b	n	D2
3	7.50 (191)	5.50 (140)	6.00 (152)	.94 (24)	4	.75 (19)

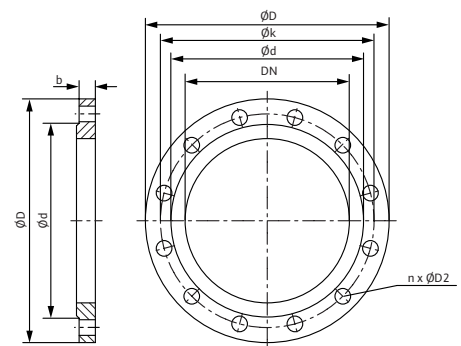

Submittal Data Sheet

Wilo SCP – Horizontal Split Case Pumps



SCP 4 x 3 x 14 DS

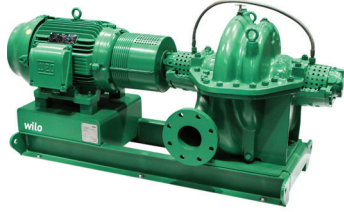

Project:	
Engineer:	
Contractor:	
Submitted By:	Date:
Approved By:	Date:

Tag #	Model #	Flow (USGPM)	Head (Feet)	HP	Enclosure TEFC/ODP	Frame	Cycle	Phase	Voltage	RPM
	SCP 4 x 3 x 14 DS						60 Hz	3		

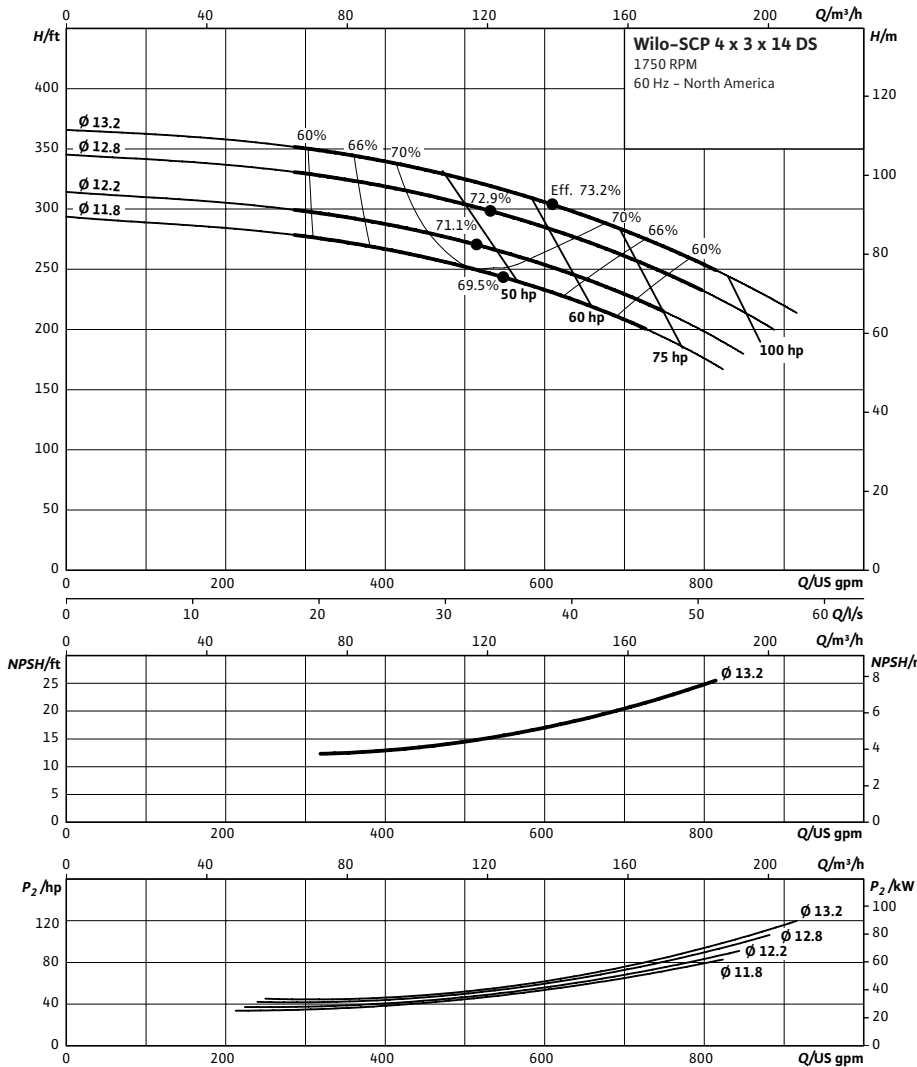

Technical Data

Approved Fluids

Heating Water
Cooling and cold water

Water-Glycol mixtures (for 20-40% glycol and fluid temp ≤ 104°F [40°C])

Fluid Temperature

Mechanical Seal 18°F to 250°F (-8°C to 120°C)
Stuffing Box Packing 18°F to 220°F (-8°C to 105°C)

Materials of Construction

<input type="checkbox"/>	Pump Housing	A48 Class 35
<input type="checkbox"/>	Pump Housing (Optional)	Ni-resist BS 3468 Gr 2 / BS 2789 500.1
<input type="checkbox"/>	Impeller	BS 84 C83 600
<input type="checkbox"/>	Impeller (optional)	A48 Class 35 / BS 84 C83 600
<input type="checkbox"/>	Stationary Wear Rings	BS 84 C93 700
<input type="checkbox"/>	Pump Shaft	A276 type 410
<input type="checkbox"/>	Pump Shaft (optional)	BS 970 316 S16
<input type="checkbox"/>	Mechanical Seal	Carbon/silicon carbide/EPDM (E1)
<input type="checkbox"/>	Other Mechanical Seals	Avail. on request
<input type="checkbox"/>	Additional Spacer Coupling	Avail. on request
<input type="checkbox"/>	Other:	

Approval Stamp

Dimensional Drawing

Dual Stage Pump

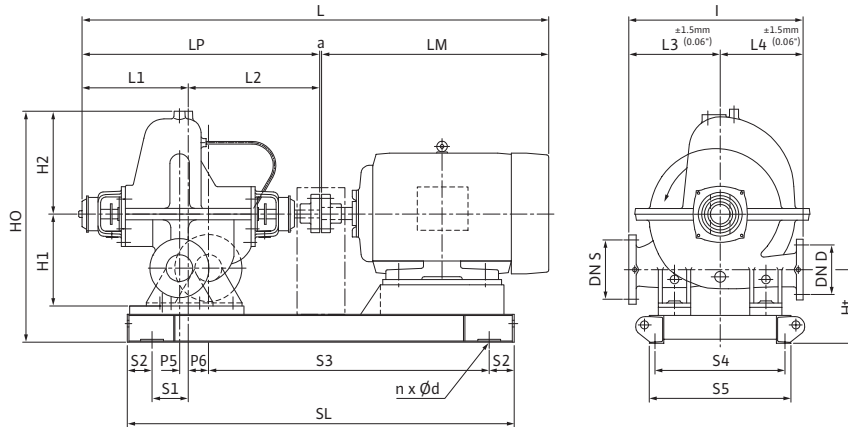

SCP 4 x 3 x 14 DS

Dimensions - Inches (mm)

Frame	a	L	I	L1	L2	L3	L4	LM	LP	H1	H2	HO	Ht	n	Ød	S1	S2	S3	S4	S5	SL	P5	P6
326T	.50 (13)	64.94 (1649)	21.44 (545)	16.31 (414)	17.69 (449)	11.00 (279)	10.44 (256)	30.38 (772)	34.06 (865)	12.19 (310)	12.63 (321)	30.44 (773)	10.31 (262)	4	.91 (23)	2.31 (59)	4.00 (102)	41.88 (1064)	15.81 (402)	18.13 (461)	49.88 (1267)	1.38 (35)	3.38 (86)
364T	.50 (13)	67.56 (1716)	21.44 (545)	16.31 (414)	17.69 (449)	11.00 (279)	10.44 (256)	33.00 (838)	34.06 (865)	12.19 (310)	12.63 (321)	30.44 (773)	10.31 (262)	4	.91 (23)	2.31 (59)	4.00 (102)	43.38 (1101)	15.81 (402)	18.13 (461)	51.38 (1305)	1.38 (35)	3.38 (86)
365T	.50 (13)	67.56 (1716)	21.44 (545)	16.31 (414)	17.69 (449)	11.00 (279)	10.44 (256)	33.00 (838)	34.06 (865)	12.19 (310)	12.63 (321)	30.44 (773)	10.31 (262)	4	.91 (23)	2.31 (59)	4.00 (102)	43.38 (1101)	15.81 (402)	18.13 (461)	51.38 (1305)	1.38 (35)	3.38 (86)
404T	.50 (13)	71.75 (1822)	21.44 (545)	16.31 (414)	17.69 (449)	11.00 (279)	10.44 (256)	37.25 (946)	34.06 (865)	12.19 (310)	12.63 (321)	30.44 (773)	10.31 (262)	4	.91 (23)	2.31 (59)	4.00 (102)	47.38 (1203)	18.50 (470)	20.88 (530)	55.38 (1406)	1.38 (35)	3.38 (86)

Flange Dimensions – Suction Side

Dimensions - Inches (mm)

DN S #125	ØD	Ød	Øk	b	n	D2
4	9.00 (229)	6.19 (157)	7.50 (191)	.94 (24)	8	.75 (19)

Flange Dimensions – Discharge Side

Dimensions - Inches (mm)

DN D 125#	ØD	Ød	Øk	b	n	D2
3	7.50 (191)	5.50 (140)	6.00 (152)	.94 (24)	4	.75 (19)

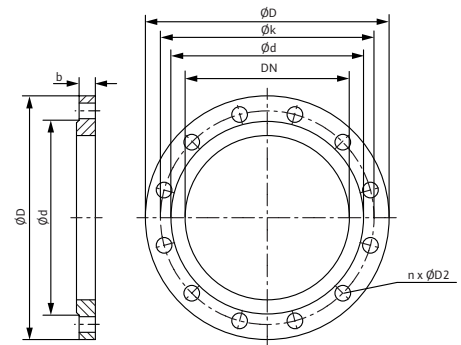

Submittal Data Sheet

Wilco SCP – Horizontal Split Case Pumps



SCP 4 x 3 x 15 DS

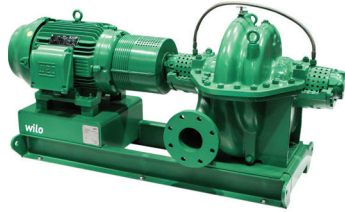

Project:	
Engineer:	
Contractor:	
Submitted By:	Date:
Approved By:	Date:

Tag #	Model #	Flow (USGPM)	Head (Feet)	HP	Enclosure TEFC/ODP	Frame	Cycle	Phase	Voltage	RPM
	SCP 4 x 3 x 15 DS						60 Hz	3		

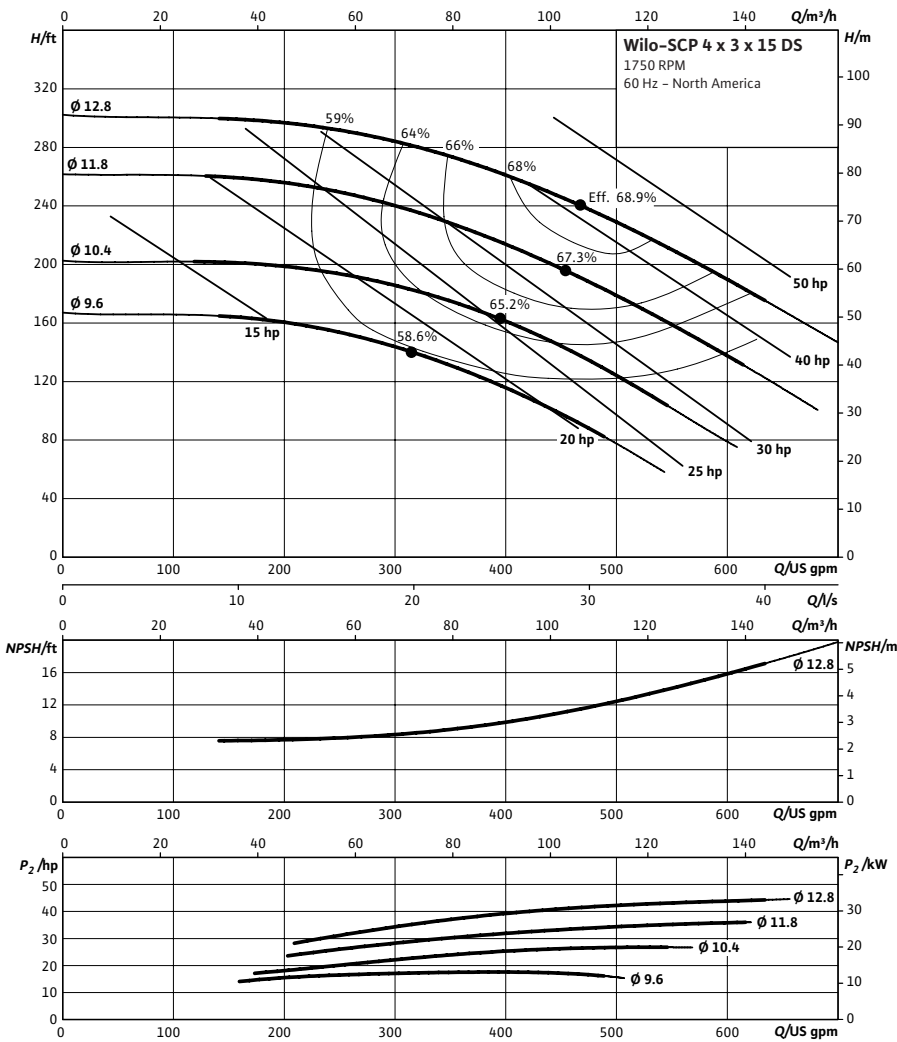

Technical Data

Approved Fluids

- Heating Water
- Cooling and cold water
- Water-Glycol mixtures (for 20-40% glycol and fluid temp $\leq 104^\circ\text{F}$ [40°C])

Fluid Temperature

- Mechanical Seal: 18°F to 250°F (-8°C to 120°C)
- Stuffing Box Packing: 18°F to 220°F (-8°C to 105°C)

Materials of Construction

<input type="checkbox"/> Pump Housing	A48 Class 35
<input type="checkbox"/> Pump Housing (Optional)	Ni-resist BS 3468 Gr 2 / BS 2789 500.1
<input type="checkbox"/> Impeller	BS 84 C83 600
<input type="checkbox"/> Impeller (optional)	A48 Class 35 / BS 84 C83 600
<input type="checkbox"/> Stationary Wear Rings	BS 84 C93 700
<input type="checkbox"/> Pump Shaft	A276 type 410
<input type="checkbox"/> Pump Shaft (optional)	BS 970 316 S16
<input type="checkbox"/> Mechanical Seal	Carbon/silicon carbide/EPDM (E1)
<input type="checkbox"/> Other Mechanical Seals	Avail. on request
<input type="checkbox"/> Additional Spacer Coupling	Avail. on request
<input type="checkbox"/> Other:	

Approval Stamp

Dimensional Drawing

Dual Stage Pump

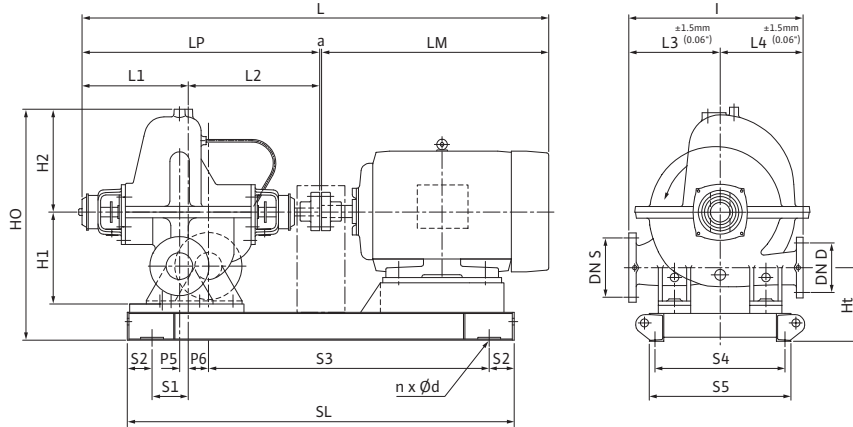

SCP 4 x 3 x 15 DS

Dimensions - Inches (mm)

Frame	a	L	I	L1	L2	L3	L4	LM	LP	H1	H2	HO	Ht	n	Ød	S1	S2	S3	S4	S5	SL	P5	P6
254T	.50 (13)	56.25 (1249)	22.69 (579)	16.63 (422)	18.06 (459)	13.19 (335)	9.50 (241)	21.06 (535)	34.69 (881)	13.38 (340)	9.81 (249)	28.88 (734)	10.88 (276)	4	.91 (23)	3.69 (94)	4.00 (102)	37.38 (950)	11.31 (287)	13.63 (346)	45.38 (1153)	2.06 (52)	5.44 (138)
256T	.50 (13)	58.31 (1481)	22.69 (579)	16.63 (422)	18.06 (459)	13.19 (335)	9.50 (241)	23.19 (589)	34.69 (881)	13.38 (340)	9.81 (249)	28.88 (734)	10.88 (276)	4	.91 (23)	3.69 (94)	4.00 (102)	39.13 (994)	11.31 (287)	13.63 (346)	47.13 (1197)	2.06 (52)	5.44 (138)
284T	.50 (13)	61.13 (1553)	22.69 (579)	16.63 (422)	18.06 (459)	13.19 (335)	9.50 (241)	25.94 (689)	34.69 (881)	13.38 (340)	9.81 (249)	28.88 (734)	10.88 (276)	4	.91 (23)	3.69 (94)	4.00 (102)	41.25 (1048)	12.31 (313)	14.63 (372)	49.25 (1251)	2.06 (52)	5.44 (138)
286T	.50 (13)	61.13 (1553)	22.69 (579)	16.63 (422)	18.06 (459)	13.19 (335)	9.50 (241)	25.94 (689)	34.69 (881)	13.38 (340)	9.81 (249)	28.88 (734)	10.88 (276)	4	.91 (23)	3.69 (94)	4.00 (102)	41.25 (1048)	12.31 (313)	14.63 (372)	49.25 (1251)	2.06 (52)	5.44 (138)
324T	.50 (13)	65.56 (1665)	22.69 (579)	16.63 (422)	18.06 (459)	13.19 (335)	9.50 (241)	30.38 (772)	34.69 (881)	13.38 (340)	9.81 (249)	28.88 (734)	10.88 (276)	4	.91 (23)	3.69 (94)	4.00 (102)	43.63 (1108)	14.31 (363)	16.63 (422)	51.63 (1311)	2.06 (52)	5.44 (138)
326T	.50 (13)	65.56 (1665)	22.69 (579)	16.63 (422)	18.06 (459)	13.19 (335)	9.50 (241)	30.38 (772)	34.69 (881)	13.38 (340)	9.81 (249)	28.88 (734)	10.88 (276)	4	.91 (23)	3.69 (94)	4.00 (102)	43.63 (1108)	14.31 (363)	16.63 (422)	51.63 (1311)	2.06 (52)	5.44 (138)

Flange Dimensions – Suction Side

Dimensions - Inches (mm)

DN S #125	ØD	Ød	Øk	b	n	D2
4	9.00 (229)	6.19 (157)	7.50 (191)	.94 (24)	8	.75 (19)

Flange Dimensions – Discharge Side

Dimensions - Inches (mm)

DN D 125#	ØD	Ød	Øk	b	n	D2
3	7.50 (191)	5.50 (140)	6.00 (152)	.94 (24)	4	.75 (19)

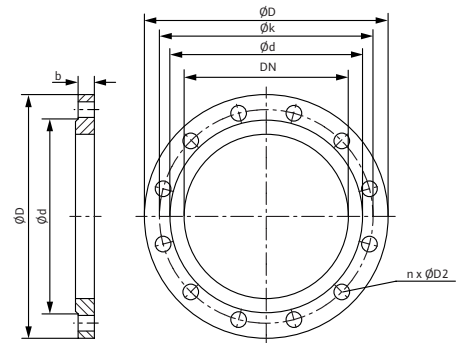

Submittal Data Sheet

Wilco SCP - Horizontal Split Case Pumps



SCP 5 x 4 x 10½ HA

	Project:									
	Engineer:									
	Contractor:									
	Submitted By:					Date:				
	Approved By:					Date:				
Tag #	Model #	Flow (USGPM)	Head (Feet)	HP	Enclosure TEFC/ODP	Frame	Cycle	Phase	Voltage	RPM
	SCP 5 x 4 x 10½ HA						60 Hz	3		

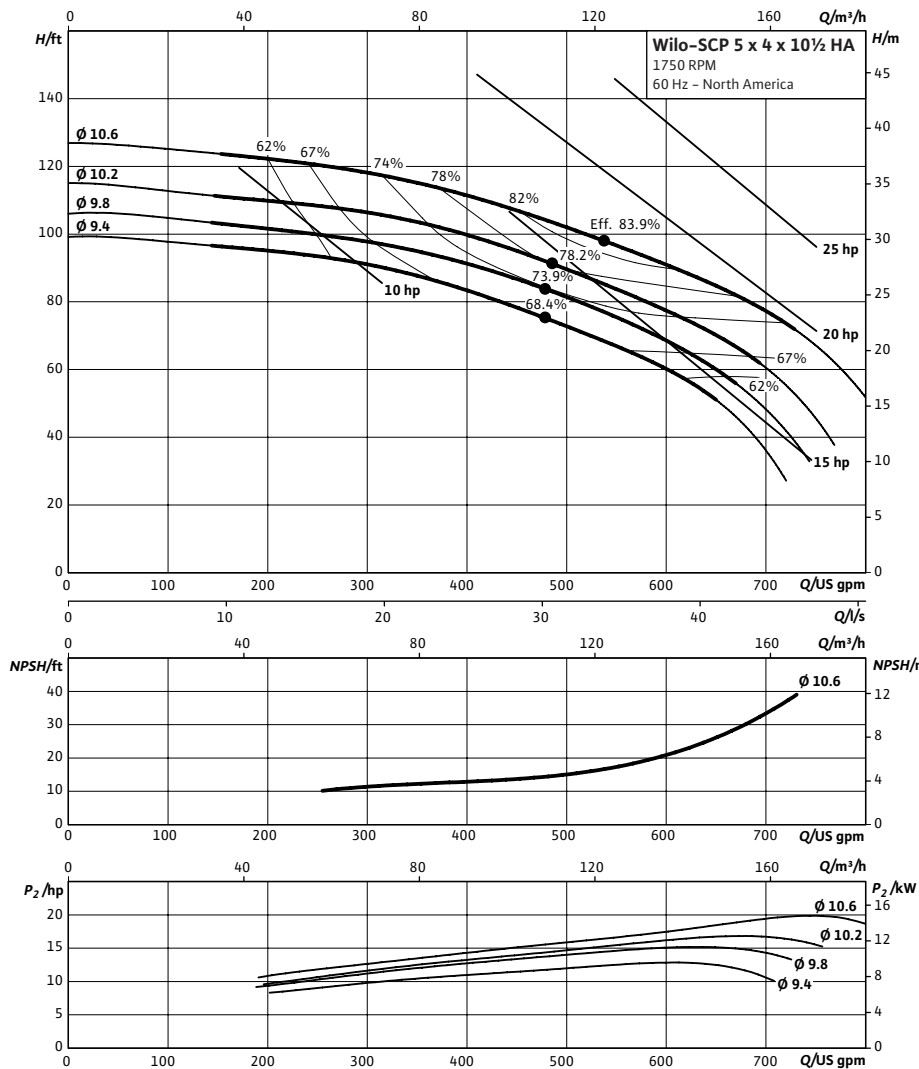

Technical Data

Approved Fluids	
Heating Water	
Cooling and cold water	
Water-Glycol mixtures (for 20-40% glycol and fluid temp ≤ 104°F [40°C])	
Fluid Temperature	
Mechanical Seal	18°F to 250°F (-8°C to 120°C)
Stuffing Box Packing	18°F to 220°F (-8°C to 105°C)

Materials of Construction

<input type="checkbox"/> Pump Housing	A48 Class 35
<input type="checkbox"/> Pump Housing (Optional)	Ni-resist BS 3468 Gr 2 / BS 2789 500.1
<input type="checkbox"/> Impeller	BS 84 C83 600
<input type="checkbox"/> Impeller (optional)	A48 Class 35 / BS 84 C83 600
<input type="checkbox"/> Stationary Wear Rings	BS 84 C93 700
<input type="checkbox"/> Pump Shaft	A276 type 410
<input type="checkbox"/> Pump Shaft (optional)	BS 970 316 S16
<input type="checkbox"/> Mechanical Seal	Carbon/silicon carbide/EPDM (E1)
<input type="checkbox"/> Other Mechanical Seals	Avail. on request
<input type="checkbox"/> Additional Spacer Coupling	Avail. on request
<input type="checkbox"/> Other:	

Approval Stamp

Dimensional Drawing

Single Stage Pump

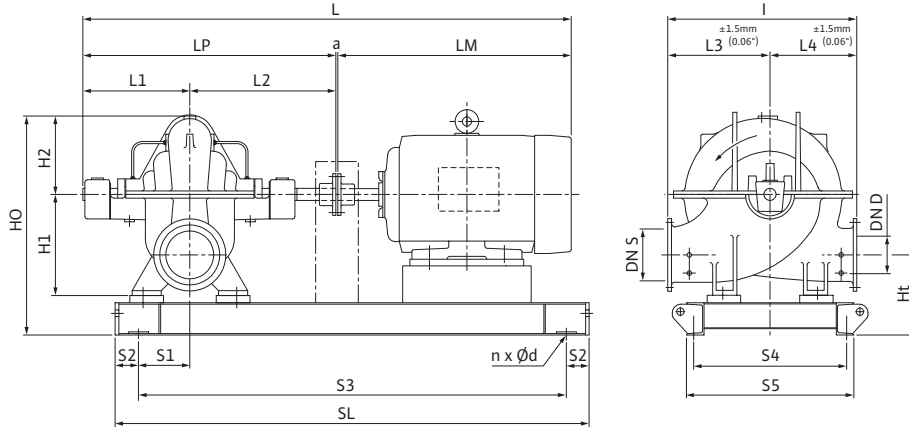

SCP 5 x 4 x 10½ HA

Dimensions - Inches (mm)

Frame	a	L	I	L1	L2	L3	L4	LM	LP	H1	H2	HO	Ht	n	Ød	S1	S2	S3	S4	S5	SL	P5	P6
215T	.50 (13)	48.88 (1242)	20.25 (514)	13.63 (346)	15.69 (399)	11.25 (286)	9.06 (230)	19.00 (483)	29.38 (746)	10.63 (270)	7.81 (198)	23.00 (584)	8.69 (221)	4	.91 (23)	4.25 (108)	4.00 (102)	32.88 (835)	12.63 (321)	14.19 (360)	40.88 (1038)	-	-
254T	.50 (13)	50.94 (1294)	20.25 (514)	13.63 (346)	15.69 (399)	11.25 (286)	9.06 (230)	21.06 (534)	29.38 (746)	10.63 (270)	7.81 (198)	23.00 (584)	8.69 (221)	4	.91 (23)	4.25 (108)	4.00 (102)	35.63 (905)	12.06 (306)	13.63 (346)	43.63 (1108)	-	-
256T	.50 (13)	53.00 (1346)	20.25 (514)	13.63 (346)	15.69 (399)	11.25 (286)	9.06 (230)	23.19 (589)	29.38 (746)	10.63 (270)	7.81 (198)	23.00 (584)	8.69 (221)	4	.91 (23)	4.25 (108)	4.00 (102)	37.38 (949)	12.06 (306)	13.63 (346)	45.38 (1152)	-	-
284T	.50 (13)	55.81 (1418)	20.25 (514)	13.63 (346)	15.69 (399)	11.25 (286)	9.06 (230)	25.94 (659)	29.38 (746)	10.63 (270)	7.81 (198)	23.00 (584)	8.69 (221)	4	.91 (23)	4.25 (108)	4.00 (102)	39.50 (1003)	13.06 (331)	14.63 (372)	47.50 (1207)	-	-
286T	.50 (13)	55.81 (1418)	20.25 (514)	13.63 (346)	15.69 (399)	11.25 (286)	9.06 (230)	25.94 (659)	29.38 (746)	10.63 (270)	7.81 (198)	23.00 (584)	8.69 (221)	4	.91 (23)	4.25 (108)	4.00 (102)	39.50 (1003)	13.06 (331)	14.63 (372)	47.50 (1207)	-	-

Flange Dimensions – Suction Side

Dimensions - Inches (mm)

DN S #125	ØD	Ød	Øk	b	n	D2
5	10.00 (254)	7.31 (186)	8.50 (216)	.94 (24)	8	.88 (22)

Flange Dimensions – Discharge Side

Dimensions - Inches (mm)

DN D 125#	ØD	Ød	Øk	b	n	D2
4	9.00 (229)	6.19 (157)	7.50 (191)	.94 (24)	8	.75 (19)

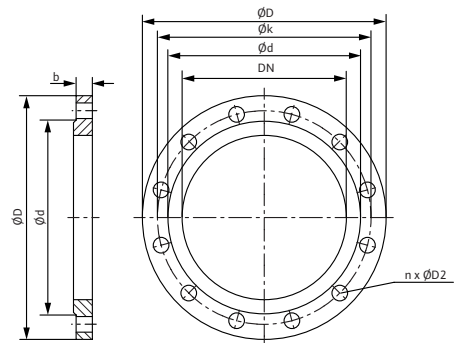

Submittal Data Sheet

Wilco SCP – Horizontal Split Case Pumps



SCP 5 x 4 x 11 HA

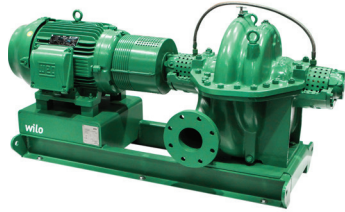

Project:	
Engineer:	
Contractor:	
Submitted By:	Date:
Approved By:	Date:

Tag #	Model #	Flow (USGPM)	Head (Feet)	HP	Enclosure TEFC/ODP	Frame	Cycle	Phase	Voltage	RPM
	SCP 5 x 4 x 11 HA						60 Hz	3		

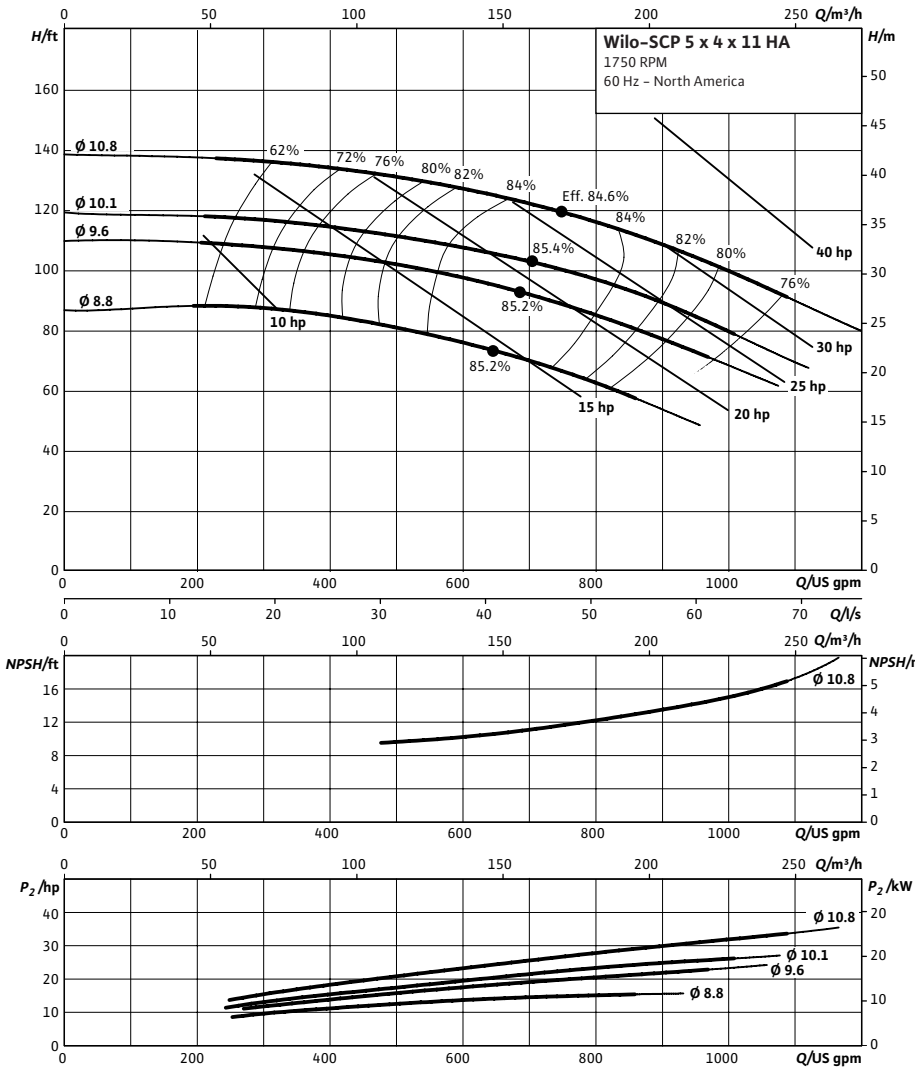

Technical Data

Approved Fluids	
Heating Water	
Cooling and cold water	
Water-Glycol mixtures (for 20–40% glycol and fluid temp ≤ 104°F [40°C])	
Fluid Temperature	
Mechanical Seal	18°F to 250°F (–8°C to 120°C)
Stuffing Box Packing	18°F to 220°F (–8°C to 105°C)

Materials of Construction

<input type="checkbox"/>	Pump Housing	A48 Class 35
<input type="checkbox"/>	Pump Housing (Optional)	Ni-resist BS 3468 Gr 2 / BS 2789 500.1
<input type="checkbox"/>	Impeller	BS 84 C83 600
<input type="checkbox"/>	Impeller (optional)	A48 Class 35 / BS 84 C83 600
<input type="checkbox"/>	Stationary Wear Rings	BS 84 C93 700
<input type="checkbox"/>	Pump Shaft	A276 type 410
<input type="checkbox"/>	Pump Shaft (optional)	BS 970 316 S16
<input type="checkbox"/>	Mechanical Seal	Carbon/silicon carbide/EPDM (E1)
<input type="checkbox"/>	Other Mechanical Seals	Avail. on request
<input type="checkbox"/>	Additional Spacer Coupling	Avail. on request
<input type="checkbox"/>	Other:	

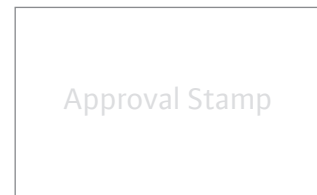

Dimensional Drawing

Single Stage Pump

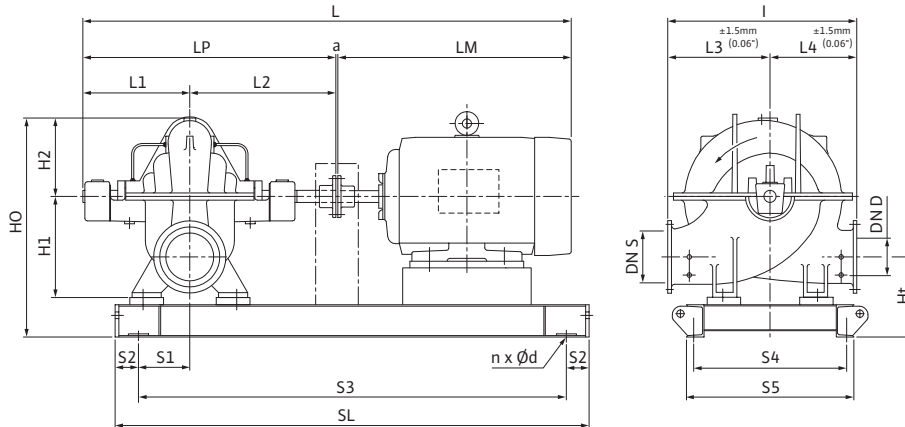

SCP 5 x 4 x 11 HA

Dimensions - Inches (mm)

Frame	a	L	I	L1	L2	L3	L4	LM	LP	H1	H2	HO	Ht	n	Ød	S1	S2	S3	S4	S5	SL	P5	P6
215T	.50 (13)	48.88 (1242)	20.25 (514)	13.63 (346)	15.69 (399)	11.25 (286)	9.06 (230)	19.00 (483)	29.38 (746)	10.63 (270)	7.81 (198)	23.00 (584)	8.69 (221)	4	.91 (23)	4.25 (108)	4.00 (102)	32.88 (835)	12.63 (321)	14.19 (360)	40.88 (1038)	-	-
254T	.50 (13)	50.94 (1294)	20.25 (514)	13.63 (346)	15.69 (399)	11.25 (286)	9.06 (230)	21.06 (534)	29.38 (746)	10.63 (270)	7.81 (198)	23.00 (584)	8.69 (221)	4	.91 (23)	4.25 (108)	4.00 (102)	35.63 (905)	12.06 (306)	13.63 (346)	43.63 (1108)	-	-
256T	.50 (13)	53.00 (1346)	20.25 (514)	13.63 (346)	15.69 (399)	11.25 (286)	9.06 (230)	23.19 (589)	29.38 (746)	10.63 (270)	7.81 (198)	23.00 (584)	8.69 (221)	4	.91 (23)	4.25 (108)	4.00 (102)	37.38 (949)	12.06 (306)	13.63 (346)	45.38 (1152)	-	-
284T	.50 (13)	55.81 (1418)	20.25 (514)	13.63 (346)	15.69 (399)	11.25 (286)	9.06 (230)	25.94 (659)	29.38 (746)	10.63 (270)	7.81 (198)	23.00 (584)	8.69 (221)	4	.91 (23)	4.25 (108)	4.00 (102)	39.50 (1003)	13.06 (331)	14.63 (372)	47.50 (1207)	-	-
286T	.50 (13)	55.81 (1418)	20.25 (514)	13.63 (346)	15.69 (399)	11.25 (286)	9.06 (230)	25.94 (659)	29.38 (746)	10.63 (270)	7.81 (198)	23.00 (584)	8.69 (221)	4	.91 (23)	4.25 (108)	4.00 (102)	39.50 (1003)	13.06 (331)	14.63 (372)	47.50 (1207)	-	-
324T	.50 (13)	60.25 (1530)	20.25 (514)	13.63 (346)	15.69 (399)	11.25 (286)	9.06 (230)	30.38 (772)	29.38 (746)	10.63 (270)	7.81 (198)	23.00 (584)	8.69 (221)	4	.91 (23)	4.25 (108)	4.00 (102)	41.88 (1064)	15.06 (383)	16.63 (422)	49.88 (1267)	-	-

Flange Dimensions – Suction Side

Dimensions - Inches (mm)

DN S #125	ØD	Ød	Øk	b	n	D2
5	10.00 (254)	7.31 (186)	8.50 (216)	.94 (24)	8	.88 (22)

Flange Dimensions – Discharge Side

Dimensions - Inches (mm)

DN D 125#	ØD	Ød	Øk	b	n	D2
4	9.00 (229)	6.19 (157)	7.50 (191)	.94 (24)	8	.75 (19)

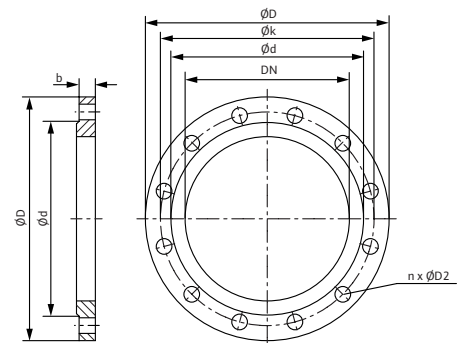

Submittal Data Sheet

Wilo SCP – Horizontal Split Case Pumps



SCP 5 x 4 x 14 HA

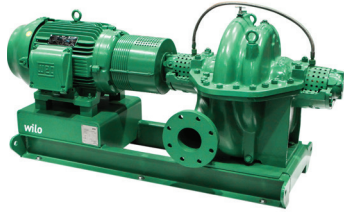

Project:	
Engineer:	
Contractor:	
Submitted By:	Date:
Approved By:	Date:

Tag #	Model #	Flow (USGPM)	Head (Feet)	HP	Enclosure TEFC/ODP	Frame	Cycle	Phase	Voltage	RPM
	SCP 5 x 4 x 14 HA						60 Hz	3		

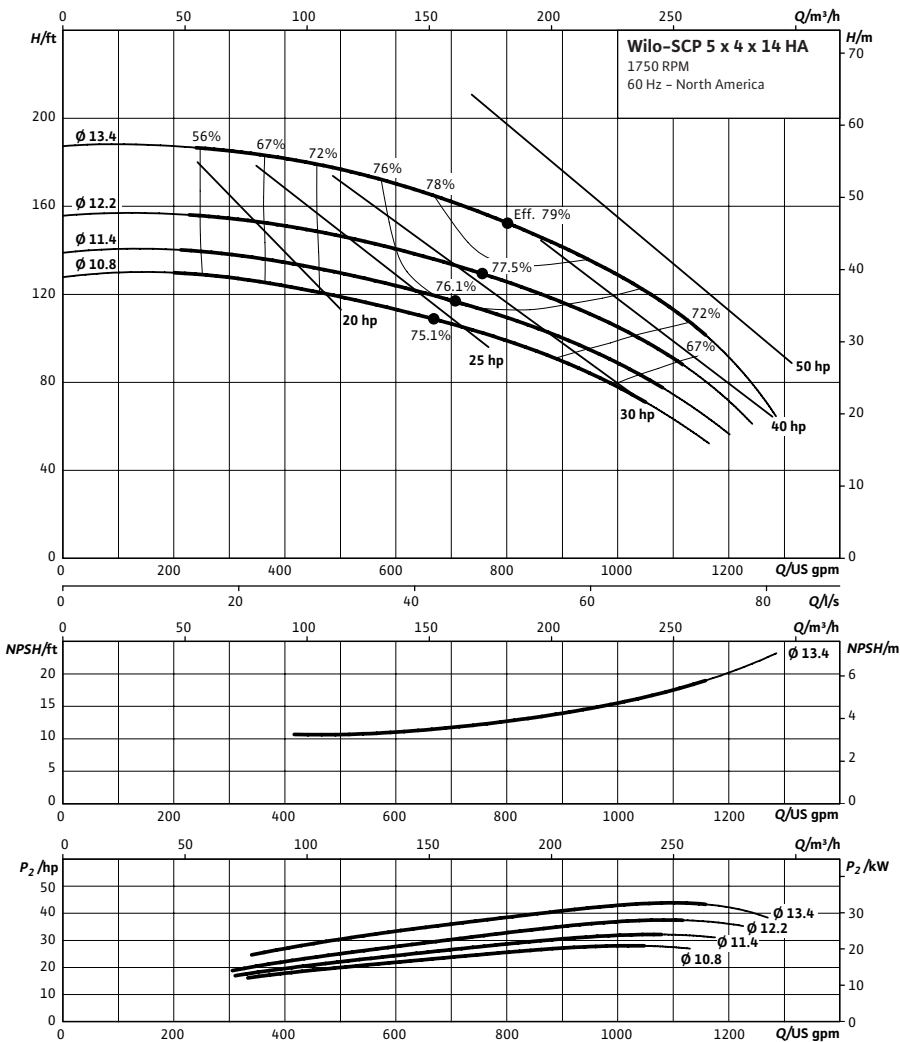

Technical Data

Approved Fluids
 Heating Water
 Cooling and cold water
 Water-Glycol mixtures (for 20-40% glycol and fluid temp ≤ 104°F [40°C])

Fluid Temperature
 Mechanical Seal: 18°F to 250°F (-8°C to 120°C)
 Stuffing Box Packing: 18°F to 220°F (-8°C to 105°C)

Materials of Construction

<input type="checkbox"/>	Pump Housing	A48 Class 35
<input type="checkbox"/>	Pump Housing (Optional)	Ni-resist BS 3468 Gr 2 / BS 2789 500.1
<input type="checkbox"/>	Impeller	BS 84 C83 600
<input type="checkbox"/>	Impeller (optional)	A48 Class 35 / BS 84 C83 600
<input type="checkbox"/>	Stationary Wear Rings	BS 84 C93 700
<input type="checkbox"/>	Pump Shaft	A276 type 410
<input type="checkbox"/>	Pump Shaft (optional)	BS 970 316 S16
<input type="checkbox"/>	Mechanical Seal	Carbon/silicon carbide/EPDM (E1)
<input type="checkbox"/>	Other Mechanical Seals	Avail. on request
<input type="checkbox"/>	Additional Spacer Coupling	Avail. on request
<input type="checkbox"/>	Other:	

Approval Stamp

Dimensional Drawing

Single Stage Pump

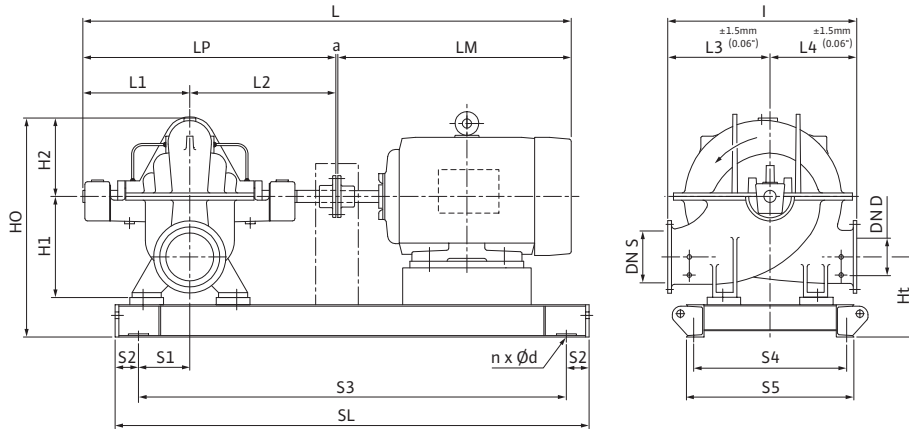

SCP 5 x 4 x 14 HA

Dimensions - Inches (mm)

Frame	a	L	I	L1	L2	L3	L4	LM	LP	H1	H2	HO	Ht	n	Ød	S1	S2	S3	S4	S5	SL	P5	P6
256T	.50 (13)	53.00 (1346)	24.63 (626)	13.63 (346)	15.69 (398)	13.75 (349)	10.81 (275)	23.06 (586)	29.38 (746)	12.63 (321)	9.63 (245)	26.88 (683)	8.38 (213)	4	.91 (23)	4.25 (108)	4.00 (102)	37.38 (949)	13.44 (341)	15.00 (381)	45.38 (1152)	-	-
284T	.50 (13)	55.81 (1418)	24.63 (626)	13.63 (346)	15.69 (398)	13.75 (349)	10.81 (275)	25.94 (659)	29.38 (746)	12.63 (321)	9.63 (245)	26.88 (683)	8.38 (213)	4	.91 (23)	4.25 (108)	4.00 (102)	39.50 (1003)	13.06 (332)	14.63 (372)	47.50 (1207)	-	-
286T	.50 (13)	55.81 (1418)	24.63 (626)	13.63 (346)	15.69 (398)	13.75 (349)	10.81 (275)	25.94 (659)	29.38 (746)	12.63 (321)	9.63 (245)	26.88 (683)	8.38 (213)	4	.91 (23)	4.25 (108)	4.00 (102)	39.50 (1003)	13.06 (332)	14.63 (372)	47.50 (1207)	-	-
324T	.50 (13)	60.25 (1530)	24.63 (626)	13.63 (346)	15.69 (398)	13.75 (349)	10.81 (275)	30.38 (772)	29.38 (746)	12.63 (321)	9.63 (245)	26.88 (683)	8.38 (213)	4	.91 (23)	4.25 (108)	4.00 (102)	41.88 (1064)	15.06 (382)	16.63 (422)	49.88 (1267)	-	-
326T	.50 (13)	60.25 (1530)	24.63 (626)	13.63 (346)	15.69 (398)	13.75 (349)	10.81 (275)	30.38 (772)	29.38 (746)	12.63 (321)	9.63 (245)	26.88 (683)	8.38 (213)	4	.91 (23)	4.25 (108)	4.00 (102)	41.88 (1064)	15.06 (382)	16.63 (422)	49.88 (1267)	-	-

Flange Dimensions – Suction Side

Dimensions - Inches (mm)

DN S #125	ØD	Ød	Øk	b	n	D2
5	10.00 (254)	7.31 (186)	8.50 (216)	.94 (24)	8	.88 (22)

Flange Dimensions – Discharge Side

Dimensions - Inches (mm)

DN D 125#	ØD	Ød	Øk	b	n	D2
4	9.00 (229)	6.19 (157)	7.50 (191)	.94 (24)	8	.75 (19)

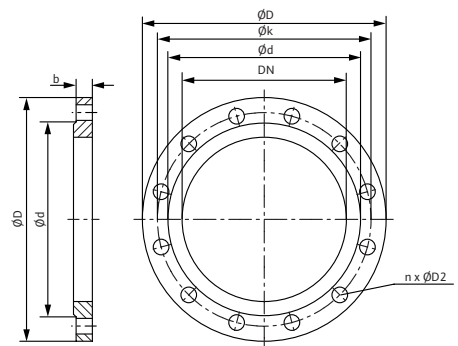

Submittal Data Sheet

Wilo SCP – Horizontal Split Case Pumps



SCP 5 x 4 x 15½ HA

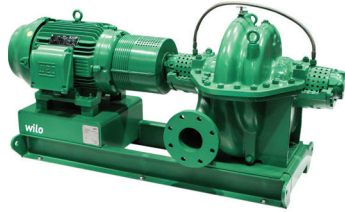

Project:	
Engineer:	
Contractor:	
Submitted By:	Date:
Approved By:	Date:

Tag #	Model #	Flow (USGPM)	Head (Feet)	HP	Enclosure TEFC/ODP	Frame	Cycle	Phase	Voltage	RPM
	SCP 5 x 4 x 15½ HA						60 Hz	3		

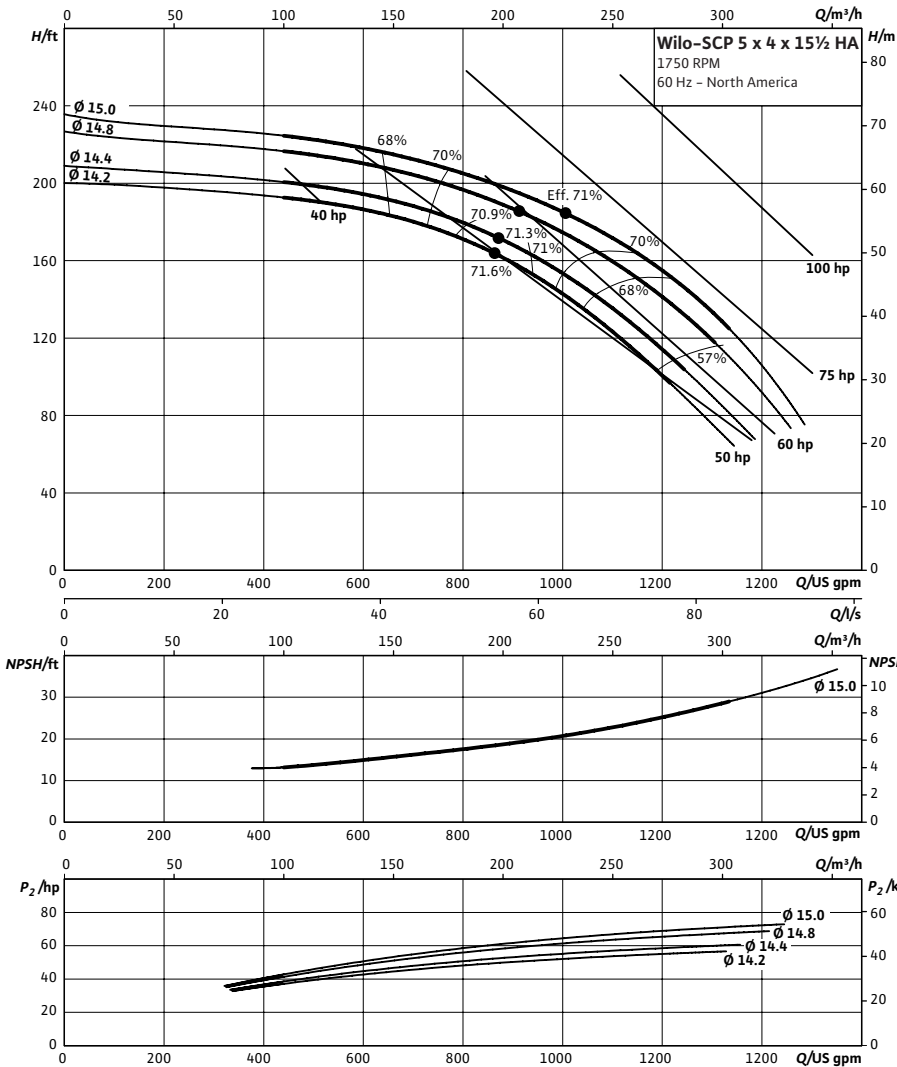

Technical Data

Approved Fluids

Heating Water
Cooling and cold water

Water-Glycol mixtures (for 20-40% glycol and fluid temp ≤ 104°F [40°C])

Fluid Temperature

Mechanical Seal 18°F to 250°F (-8°C to 120°C)
Stuffing Box Packing 18°F to 220°F (-8°C to 105°C)

Materials of Construction

<input type="checkbox"/> Pump Housing	A48 Class 35
<input type="checkbox"/> Pump Housing (Optional)	Ni-resist BS 3468 Gr 2 / BS 2789 500.1
<input type="checkbox"/> Impeller	BS 84 C83 600
<input type="checkbox"/> Impeller (optional)	A48 Class 35 / BS 84 C83 600
<input type="checkbox"/> Stationary Wear Rings	BS 84 C93 700
<input type="checkbox"/> Pump Shaft	A276 type 410
<input type="checkbox"/> Pump Shaft (optional)	BS 970 316 S16
<input type="checkbox"/> Mechanical Seal	Carbon/silicon carbide/EPDM (E1)
<input type="checkbox"/> Other Mechanical Seals	Avail. on request
<input type="checkbox"/> Additional Spacer Coupling	Avail. on request
<input type="checkbox"/> Other:	

Approval Stamp

Dimensional Drawing

Single Stage Pump

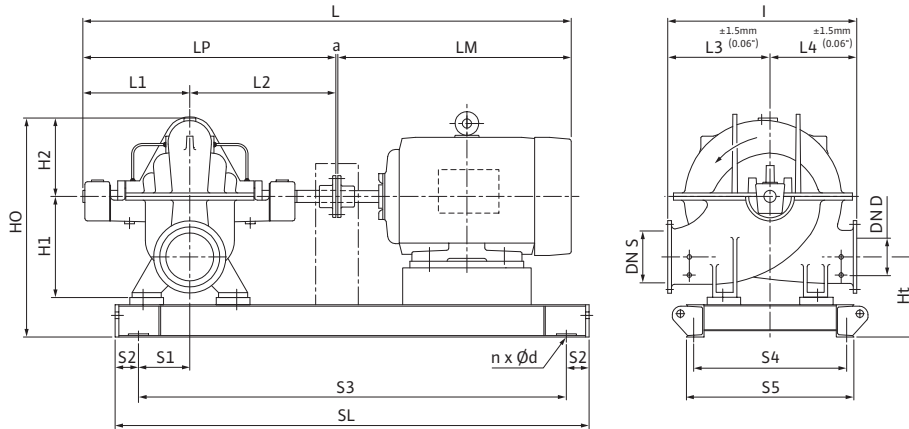

SCP 5 x 4 x 1½ HA

Dimensions - Inches (mm)

Frame	a	L	I	L1	L2	L3	L4	LM	LP	H1	H2	HO	Ht	n	Ød	S1	S2	S3	S4	S5	SL	P5	P6
324T	.50 (13)	60.25 (1530)	24.63 (626)	13.63 (346)	15.69 (398)	13.75 (349)	10.81 (275)	30.38 (772)	29.38 (746)	12.63 (321)	9.63 (245)	26.88 (683)	8.38 (213)	4	.91 (23)	4.25 (108)	4.00 (102)	41.88 (1064)	15.06 (382)	16.63 (422)	49.88 (1267)	-	-
326T	.50 (13)	60.25 (1530)	24.63 (626)	13.63 (346)	15.69 (398)	13.75 (349)	10.81 (275)	30.38 (772)	29.38 (746)	12.63 (321)	9.63 (245)	26.88 (683)	8.38 (213)	4	.91 (23)	4.25 (108)	4.00 (102)	41.88 (1064)	15.06 (382)	16.63 (422)	49.88 (1267)	-	-
364T	.50 (13)	62.88 (1597)	24.63 (626)	13.63 (346)	15.69 (398)	13.75 (349)	10.81 (275)	33.00 (838)	29.38 (746)	12.63 (321)	9.63 (245)	26.88 (683)	8.38 (213)	4	.91 (23)	4.25 (108)	4.00 (102)	43.38 (1102)	16.56 (421)	18.13 (461)	51.38 (1305)	-	-
365T	.50 (13)	62.88 (1597)	24.63 (626)	13.63 (346)	15.69 (398)	13.75 (349)	10.81 (275)	33.00 (838)	29.38 (746)	12.63 (321)	9.63 (245)	26.88 (683)	8.38 (213)	4	.91 (23)	4.25 (108)	4.00 (102)	43.38 (1102)	16.56 (421)	18.13 (461)	51.38 (1305)	-	-
404T	.50 (13)	67.06 (1703)	24.63 (626)	13.63 (346)	15.69 (398)	13.75 (349)	10.81 (275)	37.25 (946)	29.38 (746)	12.63 (321)	9.63 (245)	26.88 (683)	8.38 (213)	4	.91 (23)	4.25 (108)	4.00 (102)	47.31 (1202)	19.31 (490)	20.88 (530)	55.31 (1405)	-	-
405T	.50 (13)	74.06 (1881)	24.63 (626)	13.63 (346)	15.69 (398)	13.75 (349)	10.81 (275)	44.25 (1124)	29.38 (746)	12.63 (321)	9.63 (245)	26.88 (683)	8.38 (213)	4	.91 (23)	4.25 (108)	4.00 (102)	47.31 (1202)	19.31 (490)	20.88 (530)	55.31 (1405)	-	-

Flange Dimensions – Suction Side

Dimensions - Inches (mm)

DN S #125	ØD	Ød	Øk	b	n	D2
5	10.00 (254)	7.31 (186)	8.50 (216)	.94 (24)	8	.88 (22)

Flange Dimensions – Discharge Side

Dimensions - Inches (mm)

DN D 125#	ØD	Ød	Øk	b	n	D2
4	9.00 (229)	6.19 (157)	7.50 (191)	.94 (24)	8	.75 (19)

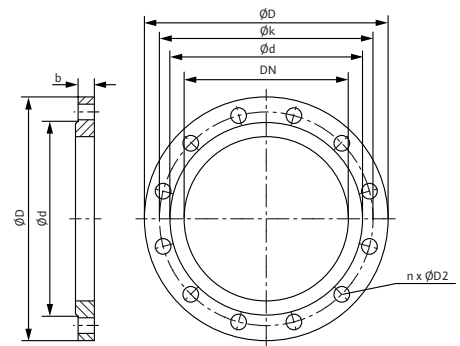

Submittal Data Sheet

Wilco SCP - Horizontal Split Case Pumps



SCP 5 x 4 x 16 DS

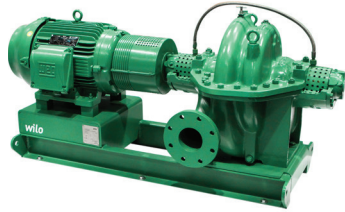

Project:	
Engineer:	
Contractor:	
Submitted By:	Date:
Approved By:	Date:

Tag #	Model #	Flow (USGPM)	Head (Feet)	HP	Enclosure TEFC/ODP	Frame	Cycle	Phase	Voltage	RPM
	SCP 5 x 4 x 16 DS						60 Hz	3		

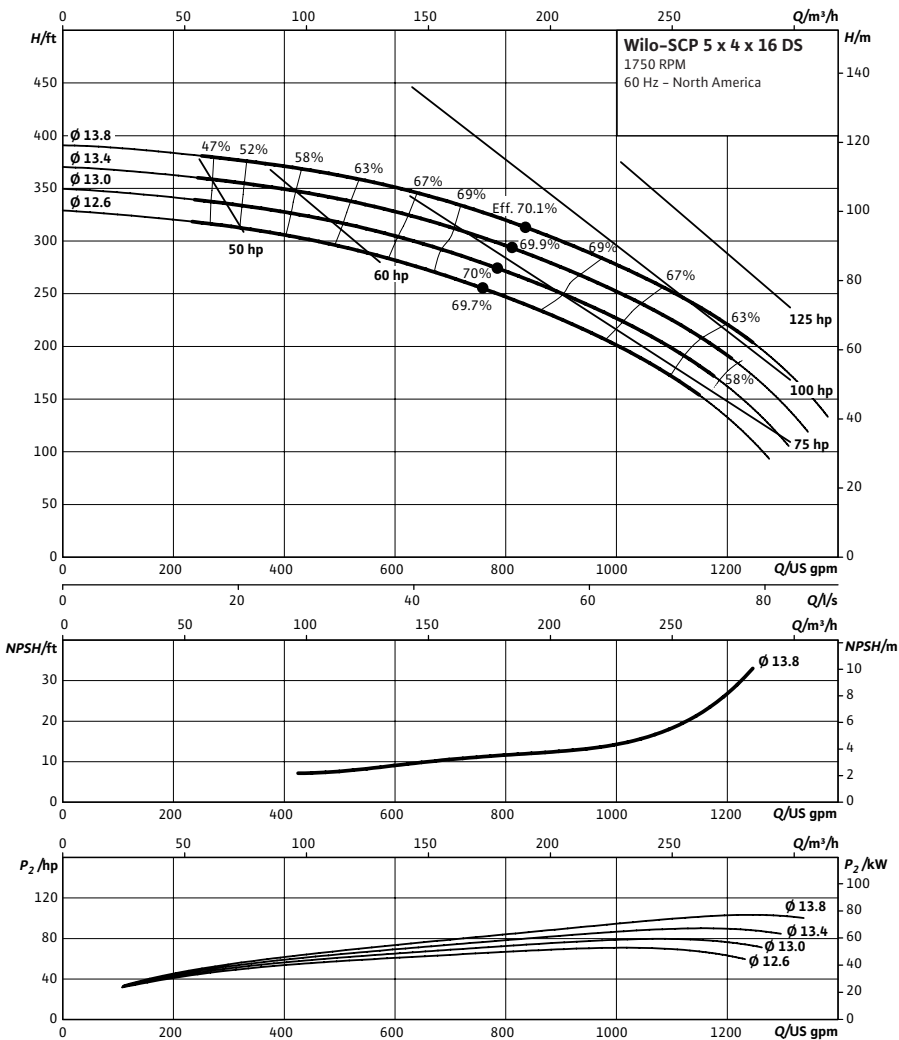

Technical Data

Approved Fluids
 Heating Water
 Cooling and cold water
 Water-Glycol mixtures (for 20-40% glycol and fluid temp ≤ 104°F [40°C])

Fluid Temperature
 Mechanical Seal: 18°F to 250°F (-8°C to 120°C)
 Stuffing Box Packing: 18°F to 220°F (-8°C to 105°C)

Materials of Construction

<input type="checkbox"/>	Pump Housing	A48 Class 35
<input type="checkbox"/>	Pump Housing (Optional)	Ni-resist BS 3468 Gr 2 / BS 2789 500.1
<input type="checkbox"/>	Impeller	BS 84 C83 600
<input type="checkbox"/>	Impeller (optional)	A48 Class 35 / BS 84 C83 600
<input type="checkbox"/>	Stationary Wear Rings	BS 84 C93 700
<input type="checkbox"/>	Pump Shaft	A276 type 410
<input type="checkbox"/>	Pump Shaft (optional)	BS 970 316 S16
<input type="checkbox"/>	Mechanical Seal	Carbon/silicon carbide/EPDM (E1)
<input type="checkbox"/>	Other Mechanical Seals	Avail. on request
<input type="checkbox"/>	Additional Spacer Coupling	Avail. on request
<input type="checkbox"/>	Other:	

Approval Stamp

Dimensional Drawing

Dual Stage Pump

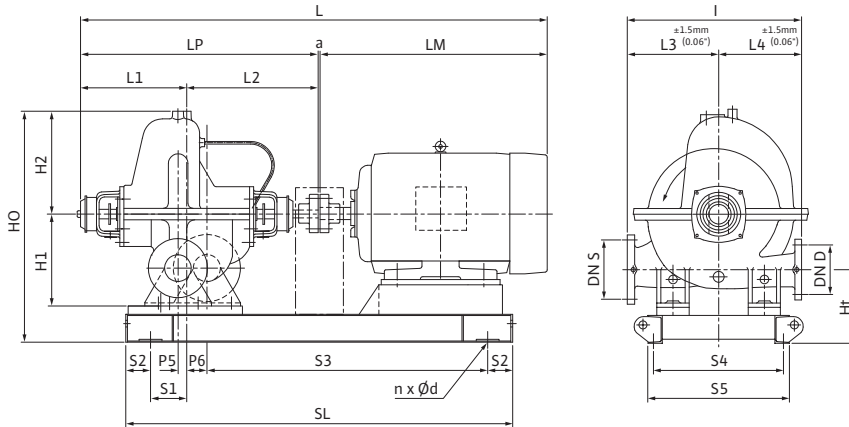

SCP 5 x 4 x 16 DS

Dimensions - Inches (mm)

Frame	a	L	I	L1	L2	L3	L4	LM	LP	H1	H2	HO	Ht	n	Ød	S1	S2	S3	S4	S5	SL	P5	P6
326T	.50 (13)	69.25 (1759)	24.44 (376)	18.31 (465)	20.06 (510)	12.63 (321)	11.81 (300)	30.38 (772)	38.38 (975)	13.75 (349)	14.38 (365)	33.81 (859)	10.75 (273)	4	.91 (23)	3.00 (76)	4.00 (102)	44.94 (1141)	15.81 (402)	18.13 (461)	54.94 (1345)	1.56 (40)	4.00 (102)
364T	.50 (13)	71.88 (1826)	24.44 (376)	18.31 (465)	20.06 (510)	12.63 (321)	11.81 (300)	33.00 (838)	38.38 (975)	13.75 (349)	14.38 (365)	33.81 (859)	10.75 (273)	4	.91 (23)	3.00 (76)	4.00 (102)	46.44 (1180)	15.81 (402)	18.13 (461)	54.44 (1383)	1.56 (40)	4.00 (102)
365T	.50 (13)	71.88 (1826)	24.44 (376)	18.31 (465)	20.06 (510)	12.63 (321)	11.81 (300)	33.00 (838)	38.38 (975)	13.75 (349)	14.38 (365)	33.81 (859)	10.75 (273)	4	.91 (23)	3.00 (76)	4.00 (102)	46.44 (1180)	15.81 (402)	18.13 (461)	54.44 (1383)	1.56 (40)	4.00 (102)
404T	.50 (13)	76.13 (1934)	24.44 (376)	18.31 (465)	20.06 (510)	12.63 (321)	11.81 (300)	37.25 (946)	38.38 (975)	13.75 (349)	14.38 (365)	33.81 (859)	10.75 (273)	4	.91 (23)	3.00 (76)	4.00 (102)	50.44 (1281)	18.50 (470)	20.88 (530)	58.44 (1484)	1.56 (40)	4.00 (102)
405T	.50 (13)	83.13 (2112)	24.44 (376)	18.31 (465)	20.06 (510)	12.63 (321)	11.81 (300)	44.25 (1124)	38.38 (975)	13.75 (349)	14.38 (365)	33.81 (859)	10.75 (273)	4	.91 (23)	3.00 (76)	4.00 (102)	50.44 (1281)	18.50 (470)	20.88 (530)	58.44 (1484)	1.56 (40)	4.00 (102)

Flange Dimensions – Suction Side

Dimensions - Inches (mm)

DN S #125	ØD	Ød	Øk	b	n	D2
5	10.00 (254)	7.31 (186)	8.50 (216)	.94 (24)	8	.88 (22)

Flange Dimensions – Discharge Side

Dimensions - Inches (mm)

DN D 125#	ØD	Ød	Øk	b	n	D2
4	9.00 (229)	6.19 (157)	7.50 (191)	.94 (24)	8	.75 (19)

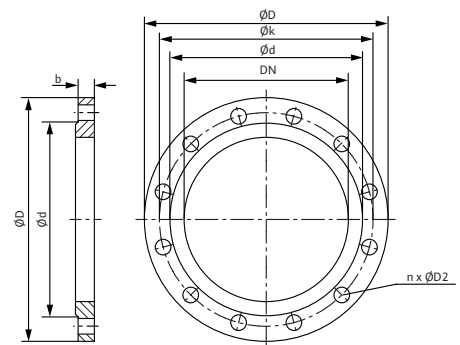

Submittal Data Sheet

Wilo SCP – Horizontal Split Case Pumps



SCP 6 x 5 x 11 HA

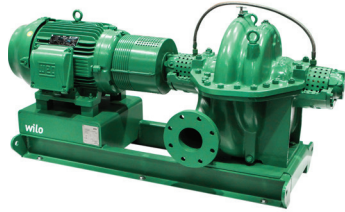

Project:	
Engineer:	
Contractor:	
Submitted By:	Date:
Approved By:	Date:

Tag #	Model #	Flow (USGPM)	Head (Feet)	HP	Enclosure TEFC/ODP	Frame	Cycle	Phase	Voltage	RPM
	SCP 6 x 5 x 11 HA						60 Hz	3		

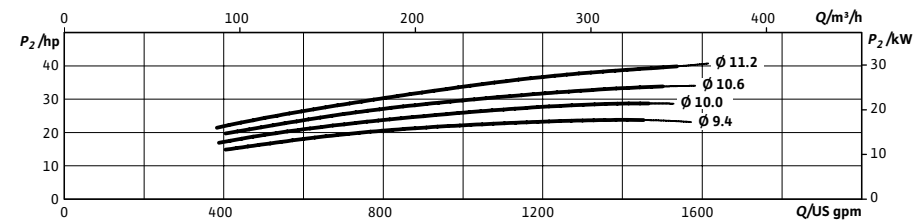
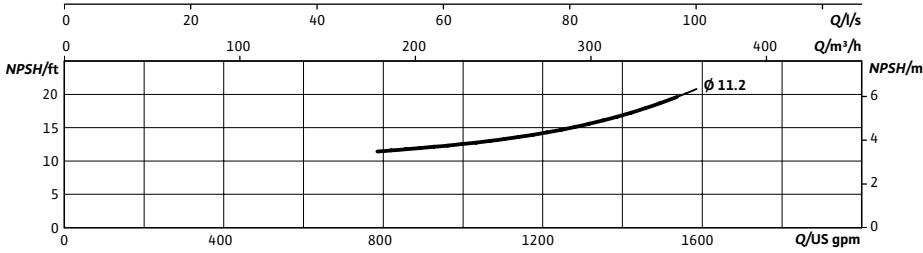
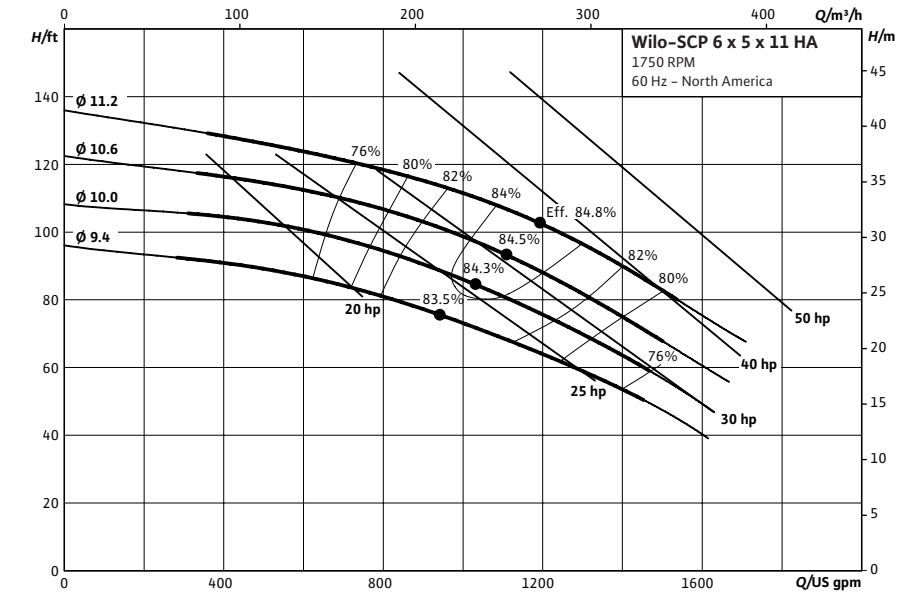

Technical Data

Approved Fluids

- Heating Water
- Cooling and cold water
- Water-Glycol mixtures (for 20-40% glycol and fluid temp ≤ 104°F [40°C])

Fluid Temperature

- Mechanical Seal: 18°F to 250°F (-8°C to 120°C)
- Stuffing Box Packing: 18°F to 220°F (-8°C to 105°C)

Materials of Construction

<input type="checkbox"/>	Pump Housing	A48 Class 35
<input type="checkbox"/>	Pump Housing (Optional)	Ni-resist BS 3468 Gr 2 / BS 2789 500.1
<input type="checkbox"/>	Impeller	BS 84 C83 600
<input type="checkbox"/>	Impeller (optional)	A48 Class 35 / BS 84 C83 600
<input type="checkbox"/>	Stationary Wear Rings	BS 84 C93 700
<input type="checkbox"/>	Pump Shaft	A276 type 410
<input type="checkbox"/>	Pump Shaft (optional)	BS 970 316 S16
<input type="checkbox"/>	Mechanical Seal	Carbon/silicon carbide/EPDM (E1)
<input type="checkbox"/>	Other Mechanical Seals	Avail. on request
<input type="checkbox"/>	Additional Spacer Coupling	Avail. on request
<input type="checkbox"/>	Other:	

Approval Stamp

Dimensional Drawing

Single Stage Pump

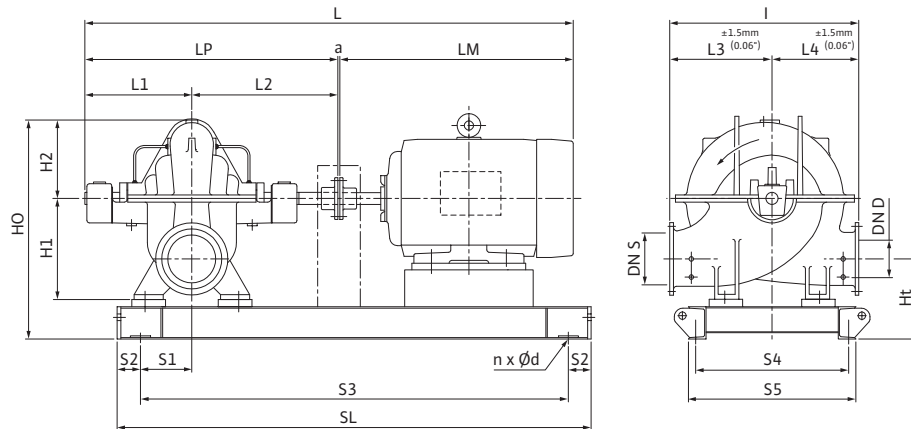

SCP 6 x 5 x 11 HA

Dimensions - Inches (mm)																							
Frame	a	L	I	L1	L2	L3	L4	LM	LP	H1	H2	HO	Ht	n	Ød	S1	S2	S3	S4	S5	SL	P5	P6
256T	.50 (13)	57.31 (1456)	24.63 (626)	15.63 (397)	18.06 (459)	13.75 (349)	10.81 (275)	23.19 (589)	33.63 (854)	12.63 (321)	9.44 (240)	27.69 (703)	9.88 (251)	4	.91 (23)	4.25 (108)	4.00 (102)	39.69 (1008)	12.63 (321)	15.00 (381)	47.69 (1211)	-	-
284T	.50 (13)	60.06 (1526)	24.63 (626)	15.63 (397)	18.06 (459)	13.75 (349)	10.81 (275)	25.94 (659)	33.63 (854)	12.63 (321)	9.44 (240)	27.69 (703)	9.88 (251)	4	.91 (23)	4.25 (108)	4.00 (102)	41.81 (1062)	12.31 (364)	14.63 (372)	49.81 (1265)	-	-
286T	.50 (13)	60.06 (1526)	24.63 (626)	15.63 (397)	18.06 (459)	13.75 (349)	10.81 (275)	25.94 (659)	33.63 (854)	12.63 (321)	9.44 (240)	27.69 (703)	9.88 (251)	4	.91 (23)	4.25 (108)	4.00 (102)	41.81 (1062)	12.31 (364)	14.63 (372)	49.81 (1265)	-	-
324T	.50 (13)	54.50 (1638)	24.63 (626)	15.63 (397)	18.06 (459)	13.75 (349)	10.81 (275)	30.38 (772)	33.63 (854)	12.63 (321)	9.44 (240)	27.69 (703)	9.88 (251)	4	.91 (23)	4.25 (108)	4.00 (102)	44.19 (1122)	14.31 (364)	16.63 (422)	52.19 (1325)	-	-
326T	.50 (13)	54.50 (1638)	24.63 (626)	15.63 (397)	18.06 (459)	13.75 (349)	10.81 (275)	30.38 (772)	33.63 (854)	12.63 (321)	9.44 (240)	27.69 (703)	9.88 (251)	4	.91 (23)	4.25 (108)	4.00 (102)	44.19 (1122)	14.31 (364)	16.63 (422)	52.19 (1325)	-	-

Flange Dimensions – Suction Side

Dimensions - Inches (mm)						
DN S #125	ØD	Ød	Øk	b	n	D2
6	11.00 (279)	8.50 (216)	9.50 (241)	1.00 (25)	8	.88 (22)

Flange Dimensions – Discharge Side

Dimensions - Inches (mm)						
DN D 125#	ØD	Ød	Øk	b	n	D2
5	10.00 (254)	7.31 (186)	8.50 (216)	.94 (24)	8	.88 (22)

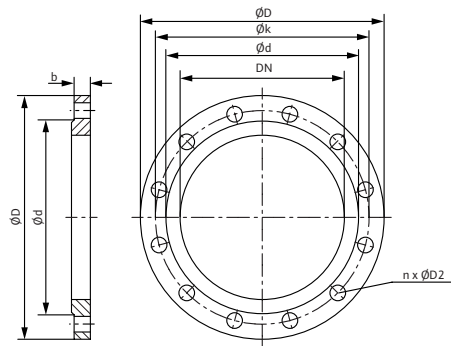

Submittal Data Sheet

Wilco SCP - Horizontal Split Case Pumps



SCP 6 x 5 x 12½ HA

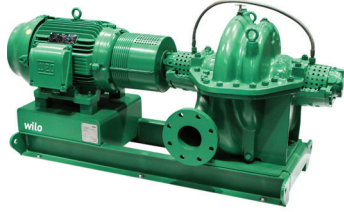

Project:	
Engineer:	
Contractor:	
Submitted By:	Date:
Approved By:	Date:

Tag #	Model #	Flow (USGPM)	Head (Feet)	HP	Enclosure TEFC/ODP	Frame	Cycle	Phase	Voltage	RPM
	SCP 6 x 5 x 12½ HA						60 Hz	3		

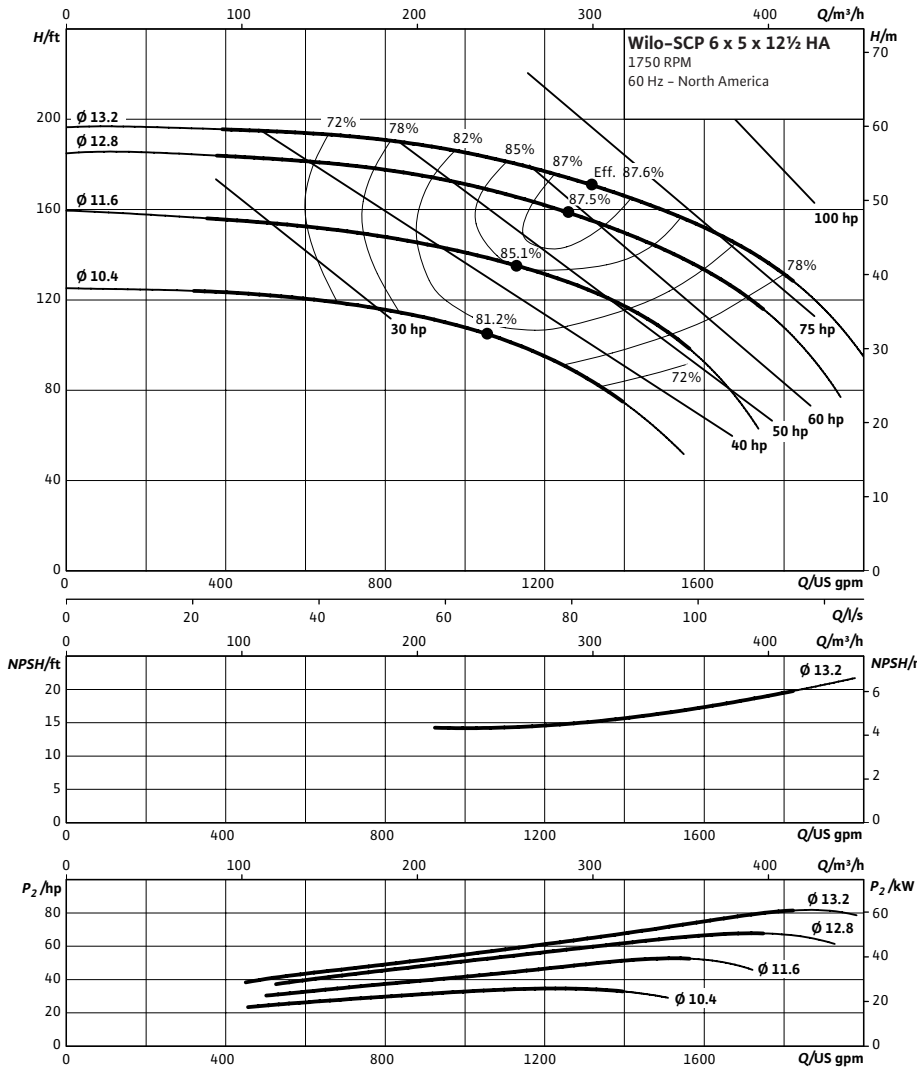

Technical Data

Approved Fluids

Heating Water
Cooling and cold water

Water-Glycol mixtures (for 20-40% glycol and fluid temp ≤ 104°F [40°C])

Fluid Temperature

Mechanical Seal: 18°F to 250°F (-8°C to 120°C)
Stuffing Box Packing: 18°F to 220°F (-8°C to 105°C)

Materials of Construction

<input type="checkbox"/> Pump Housing	A48 Class 35
<input type="checkbox"/> Pump Housing (Optional)	Ni-resist BS 3468 Gr 2 / BS 2789 500.1
<input type="checkbox"/> Impeller	BS 84 C83 600
<input type="checkbox"/> Impeller (optional)	A48 Class 35 / BS 84 C83 600
<input type="checkbox"/> Stationary Wear Rings	BS 84 C93 700
<input type="checkbox"/> Pump Shaft	A276 type 410
<input type="checkbox"/> Pump Shaft (optional)	BS 970 316 S16
<input type="checkbox"/> Mechanical Seal	Carbon/silicon carbide/EPDM (E1)
<input type="checkbox"/> Other Mechanical Seals	Avail. on request
<input type="checkbox"/> Additional Spacer Coupling	Avail. on request
<input type="checkbox"/> Other:	

Approval Stamp

Dimensional Drawing

Single Stage Pump

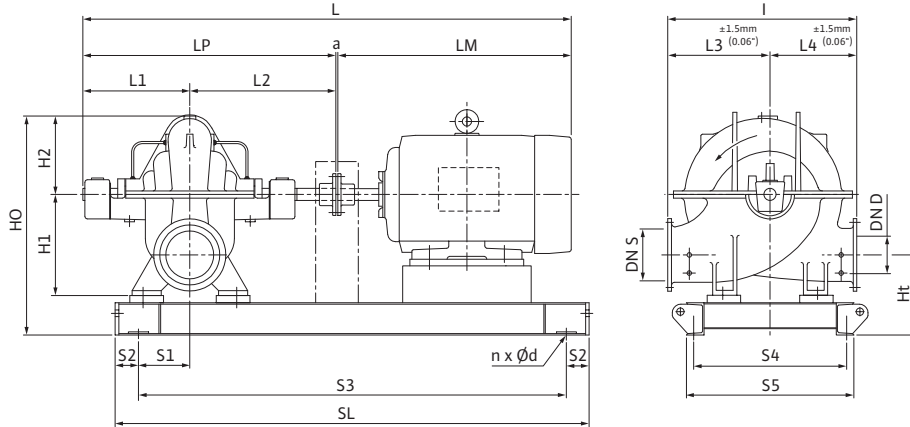

SCP 6 x 5 x 12½ HA

Dimensions - Inches (mm)

Frame	a	L	I	L1	L2	L3	L4	LM	LP	H1	H2	HO	Ht	n	Ød	S1	S2	S3	S4	S5	SL	P5	P6
286T	.50 (13)	60.06 (1526)	25.06 (637)	15.63 (397)	18.06 (459)	13.75 (349)	11.25 (286)	25.94 (659)	33.63 (854)	12.63 (321)	9.44 (240)	27.69 (703)	9.88 (251)	4	.91 (23)	4.25 (108)	4.00 (102)	41.81 (1062)	12.31 (313)	14.63 (372)	49.81 (1265)	-	-
324T	.50 (13)	54.50 (1638)	25.06 (637)	15.63 (397)	18.06 (459)	13.75 (349)	11.25 (286)	30.38 (772)	33.63 (854)	12.63 (321)	9.44 (240)	27.69 (703)	9.88 (251)	4	.91 (23)	4.25 (108)	4.00 (102)	44.19 (1122)	14.31 (363)	15.63 (422)	52.19 (1326)	-	-
326T	.50 (13)	54.50 (1638)	25.06 (637)	15.63 (397)	18.06 (459)	13.75 (349)	11.25 (286)	30.38 (772)	33.63 (854)	12.63 (321)	9.44 (240)	27.69 (703)	9.88 (251)	4	.91 (23)	4.25 (108)	4.00 (102)	44.19 (1122)	14.31 (363)	15.63 (422)	52.19 (1326)	-	-
364T	.50 (13)	67.13 (1705)	25.06 (637)	15.63 (397)	18.06 (459)	13.75 (349)	11.25 (286)	33.00 (838)	33.63 (854)	12.63 (321)	9.44 (240)	27.69 (703)	9.88 (251)	4	.91 (23)	4.25 (108)	4.00 (102)	45.69 (1161)	15.81 (402)	18.13 (461)	53.69 (1364)	-	-
365T	.50 (13)	67.13 (1705)	25.06 (637)	15.63 (397)	18.06 (459)	13.75 (349)	11.25 (286)	33.00 (838)	33.63 (854)	12.63 (321)	9.44 (240)	27.69 (703)	9.88 (251)	4	.91 (23)	4.25 (108)	4.00 (102)	45.69 (1161)	15.81 (402)	18.13 (461)	53.69 (1364)	-	-
404T	.50 (13)	71.38 (1813)	25.06 (637)	15.63 (397)	18.06 (459)	13.75 (349)	11.25 (286)	37.25 (946)	33.63 (854)	12.63 (321)	9.44 (240)	27.69 (703)	9.88 (251)	4	.91 (23)	4.25 (108)	4.00 (102)	49.69 (1262)	18.50 (470)	20.88 (530)	57.69 (1465)	-	-

Flange Dimensions – Suction Side

Dimensions - Inches (mm)

DN S #125	ØD	Ød	Øk	b	n	D2
6	11.00 (279)	8.50 (216)	9.50 (241)	1.00 (25)	8	.88 (22)

Flange Dimensions – Discharge Side

Dimensions - Inches (mm)

DN D 125#	ØD	Ød	Øk	b	n	D2
5	10.00 (254)	7.31 (186)	8.50 (216)	.94 (24)	8	.88 (22)

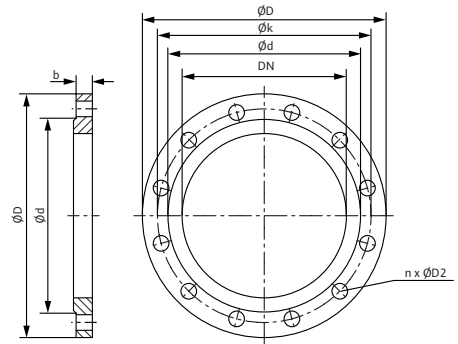

Submittal Data Sheet

Wilo SCP – Horizontal Split Case Pumps



SCP 6 x 5 x 18 DS

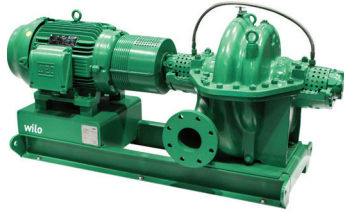

Project:	
Engineer:	
Contractor:	
Submitted By:	Date:
Approved By:	Date:

Tag #	Model #	Flow (USGPM)	Head (Feet)	HP	Enclosure TEFC/ODP	Frame	Cycle	Phase	Voltage	RPM
	SCP 6 x 5 x 18 DS						60 Hz	3		

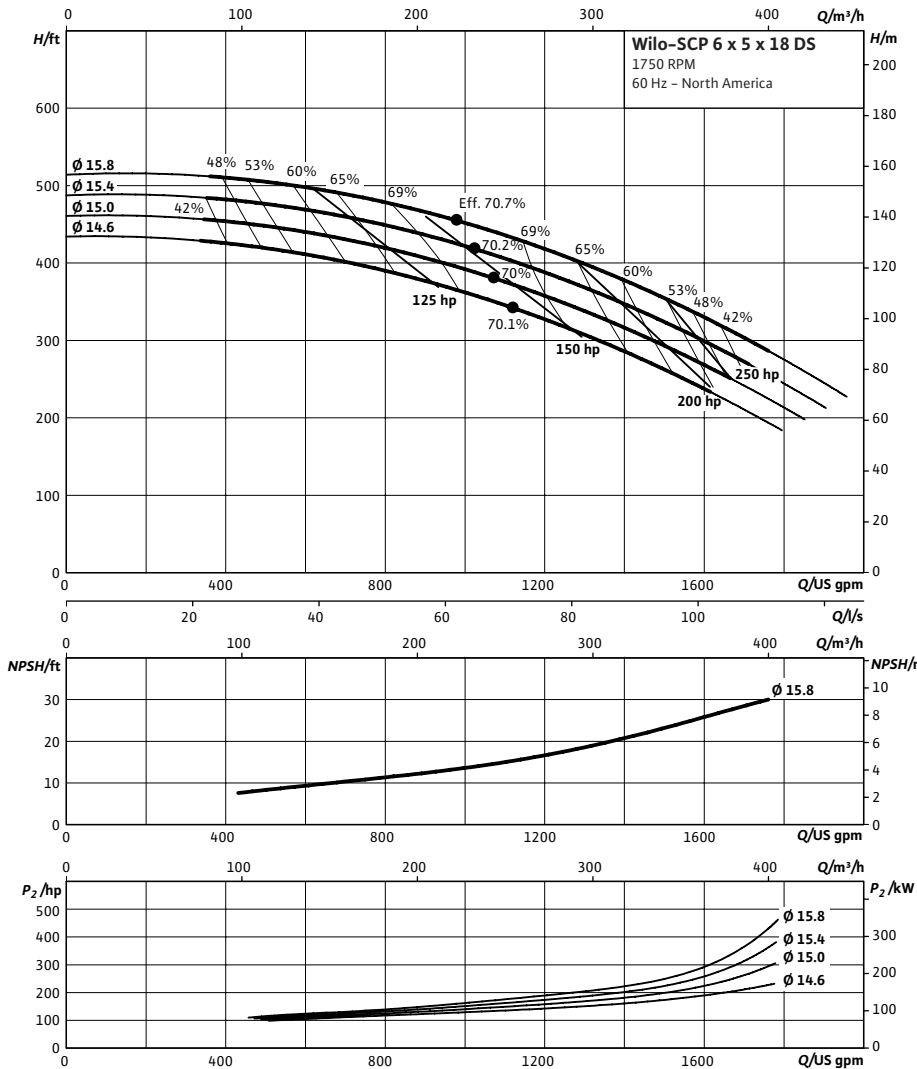

Technical Data

Approved Fluids

- Heating Water
- Cooling and cold water
- Water-Glycol mixtures (for 20–40% glycol and fluid temp \leq 104°F [40°C])

Fluid Temperature

- Mechanical Seal: 18°F to 250°F (–8°C to 120°C)
- Stuffing Box Packing: 18°F to 220°F (–8°C to 105°C)

Materials of Construction

<input type="checkbox"/> Pump Housing	A48 Class 35
<input type="checkbox"/> Pump Housing (Optional)	Ni-resist BS 3468 Gr 2 / BS 2789 500.1
<input type="checkbox"/> Impeller	BS 84 C83 600
<input type="checkbox"/> Impeller (optional)	A48 Class 35 / BS 84 C83 600
<input type="checkbox"/> Stationary Wear Rings	BS 84 C93 700
<input type="checkbox"/> Pump Shaft	A276 type 410
<input type="checkbox"/> Pump Shaft (optional)	BS 970 316 S16
<input type="checkbox"/> Mechanical Seal	Carbon/silicon carbide/EPDM (E1)
<input type="checkbox"/> Other Mechanical Seals	Avail. on request
<input type="checkbox"/> Additional Spacer Coupling	Avail. on request
<input type="checkbox"/> Other:	

Approval Stamp

Dimensional Drawing

Dual Stage Pump

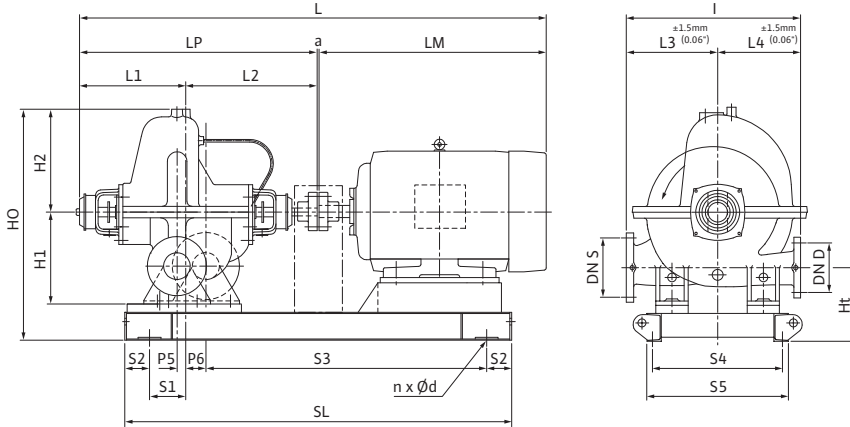

SCP 6 x 5 x 18 DS

Dimensions - Inches (mm)

Frame	a	L	I	L1	L2	L3	L4	LM	LP	H1	H2	HO	Ht	n	Ød	S1	S2	S3	S4	S5	SL	P5	P6
405T	.50 (13)	88.06 (2237)	29.50 (749)	20.50 (521)	22.81 (579)	15.75 (400)	13.75 (349)	44.25 (1124)	43.31 (1100)	15.75 (400)	16.13 (410)	37.69 (957)	11.94 (303)	4	.91 (23)	3.88 (99)	4.00 (102)	54.06 (1373)	21.13 (537)	23.44 (595)	62.06 (1576)	1.75 (44)	4.31 (110)
444T	.50 (13)	88.06 (2237)	29.50 (749)	20.50 (521)	22.81 (579)	15.75 (400)	13.75 (349)	44.25 (1124)	43.31 (1100)	15.75 (400)	16.13 (410)	37.69 (957)	11.94 (303)	4	.91 (23)	3.88 (99)	4.00 (102)	59.19 (1503)	21.69 (551)	23.88 (607)	67.19 (1707)	1.75 (44)	4.31 (110)
445T/ 200 hp	.50 (13)	88.06 (2237)	29.50 (749)	20.50 (521)	22.81 (579)	15.75 (400)	13.75 (349)	44.25 (1124)	43.31 (1100)	15.75 (400)	16.13 (410)	37.69 (957)	11.94 (303)	4	.91 (23)	3.88 (99)	4.00 (102)	59.19 (1503)	21.69 (551)	23.88 (607)	67.19 (1707)	1.75 (44)	4.31 (110)
445T/ 250 hp	.19 (5)	91.25 (2318)	29.50 (749)	20.50 (521)	22.81 (579)	15.75 (400)	13.75 (349)	47.75 (1213)	43.31 (1100)	15.75 (400)	16.13 (410)	37.69 (957)	11.94 (303)	4	.91 (23)	3.88 (99)	4.00 (102)	59.88 (1521)	21.69 (551)	23.88 (607)	67.88 (1724)	1.75 (44)	4.31 (110)

Flange Dimensions – Suction Side

Dimensions - Inches (mm)

DN S #125	ØD	Ød	Øk	b	n	D2
6	11.00 (279)	8.50 (216)	9.50 (241)	1.00 (25)	8	.88 (22)

Flange Dimensions – Discharge Side

Dimensions - Inches (mm)

DND 125#	ØD	Ød	Øk	b	n	D2
5	10.00 (254)	7.31 (186)	8.50 (216)	.94 (24)	8	.88 (22)

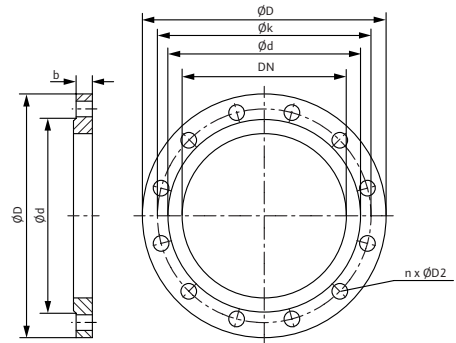

Submittal Data Sheet

Wilco SCP - Horizontal Split Case Pumps



SCP 6 x 5 x 18½ HA

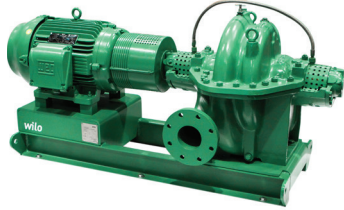

Project:										
Engineer:										
Contractor:										
Submitted By:							Date:			
Approved By:							Date:			

Tag #	Model #	Flow (USGPM)	Head (Feet)	HP	Enclosure TEFC/ODP	Frame	Cycle	Phase	Voltage	RPM
	SCP 6 x 5 x 18½ HA						60 Hz	3		

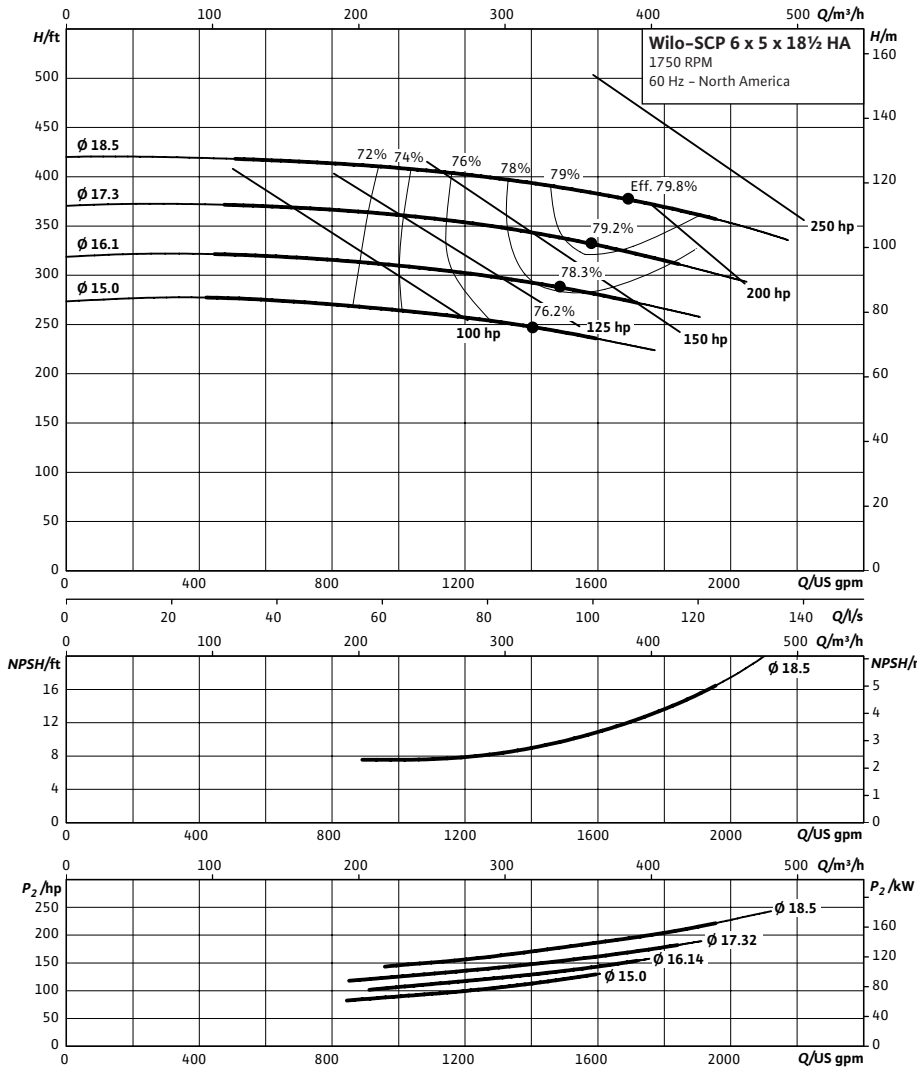

Technical Data

Approved Fluids

- Heating Water
- Cooling and cold water
- Water-Glycol mixtures (for 20-40% glycol and fluid temp ≤ 104°F [40°C])

Fluid Temperature

- Mechanical Seal: 18°F to 250°F (-8°C to 120°C)
- Stuffing Box Packing: 18°F to 220°F (-8°C to 105°C)

Materials of Construction

<input type="checkbox"/> Pump Housing	A48 Class 35
<input type="checkbox"/> Pump Housing (Optional)	Ni-resist BS 3468 Gr 2 / BS 2789 500.1
<input type="checkbox"/> Impeller	BS 84 C83 600
<input type="checkbox"/> Impeller (optional)	A48 Class 35 / BS 84 C83 600
<input type="checkbox"/> Stationary Wear Rings	BS 84 C93 700
<input type="checkbox"/> Pump Shaft	A276 type 410
<input type="checkbox"/> Pump Shaft (optional)	BS 970 316 S16
<input type="checkbox"/> Mechanical Seal	Carbon/silicon carbide/EPDM (E1)
<input type="checkbox"/> Other Mechanical Seals	Avail. on request
<input type="checkbox"/> Additional Spacer Coupling	Avail. on request
<input type="checkbox"/> Other:	

Approval Stamp

Dimensional Drawing

Single Stage Pump

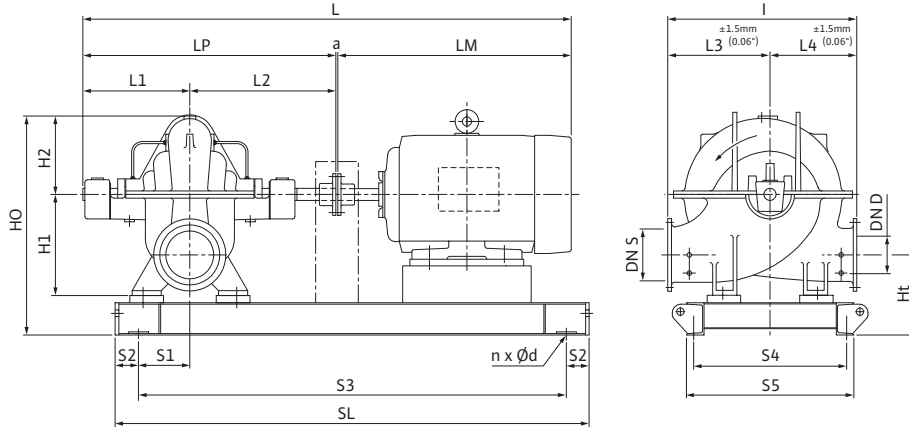

SCP 6 x 5 x 18½ HA

Dimensions - Inches (mm)

Frame	a	L	I	L1	L2	L3	L4	LM	LP	H1	H2	HO	Ht	n	Ød	S1	S2	S3	S4	S5	SL	P5	P6
404T	.50 (13)	78.81 (2002)	32.31 (821)	19.00 (483)	22.06 (560)	16.56 (421)	15.75 (400)	37.25 (946)	41.06 (1043)	16.31 (414)	12.63 (320)	34.75 (883)	10.56 (268)	4	.91 (23)	5.81 (148)	4.00 (102)	55.25 (1403)	18.94 (481)	21.31 (541)	63.25 (1607)	-	-
405T	.50 (13)	85.81 (2180)	32.31 (821)	19.00 (483)	22.06 (560)	16.56 (421)	15.75 (400)	44.25 (1124)	41.06 (1043)	16.31 (414)	12.63 (320)	34.75 (883)	10.56 (268)	4	.91 (23)	5.81 (148)	4.00 (102)	55.25 (1403)	18.94 (481)	21.31 (541)	63.25 (1607)	-	-
444T	.50 (13)	85.81 (2180)	32.31 (821)	19.00 (483)	22.06 (560)	16.56 (421)	15.75 (400)	44.25 (1124)	41.06 (1043)	16.31 (414)	12.63 (320)	34.75 (883)	10.56 (268)	4	.91 (23)	5.81 (148)	4.00 (102)	60.38 (1534)	21.56 (548)	23.88 (607)	68.38 (1737)	-	-
445T / 200 hp	.50 (13)	85.81 (2180)	32.31 (821)	19.00 (483)	22.06 (560)	16.56 (421)	15.75 (400)	44.25 (1124)	41.06 (1043)	16.31 (414)	12.63 (320)	34.75 (883)	10.56 (268)	4	.91 (23)	5.81 (148)	4.00 (102)	60.38 (1534)	21.56 (548)	23.88 (607)	68.38 (1737)	-	-
445T / 250 hp	.19 (5)	89.00 (2261)	32.31 (821)	19.00 (483)	22.06 (560)	16.56 (421)	15.75 (400)	47.75 (1213)	41.06 (1043)	16.31 (414)	12.63 (320)	34.75 (883)	10.56 (268)	4	.91 (23)	5.81 (148)	4.00 (102)	60.06 (1526)	21.56 (548)	23.88 (607)	68.06 (1728)	-	-
445T / 300 hp	.19 (5)	94.69 (2405)	32.31 (821)	19.00 (483)	22.06 (560)	16.56 (421)	15.75 (400)	53.38 (1356)	41.06 (1043)	16.31 (414)	12.63 (320)	34.75 (883)	10.56 (268)	4	.91 (23)	5.81 (148)	4.00 (102)	60.06 (1526)	21.56 (548)	23.88 (607)	68.06 (1728)	-	-

Flange Dimensions – Suction Side

Dimensions - Inches (mm)

DN S #125	ØD	Ød	Øk	b	n	D2
6	11.00 (279)	8.50 (216)	9.50 (241)	1.00 (25)	8	.88 (22)

Flange Dimensions – Discharge Side

Dimensions - Inches (mm)

DN D 125#	ØD	Ød	Øk	b	n	D2
5	10.00 (254)	7.31 (186)	8.50 (216)	.94 (24)	8	.88 (22)

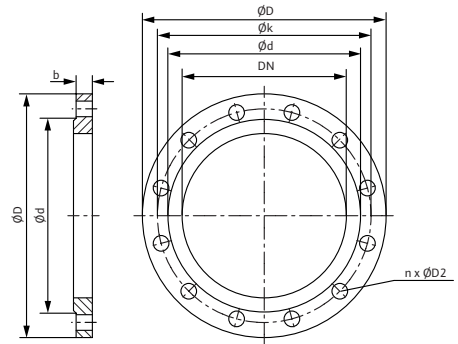

Submittal Data Sheet

Wilo SCP – Horizontal Split Case Pumps



SCP 8 x 6 x 11 HA

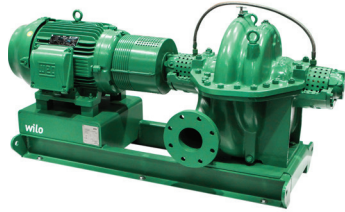

Project:	
Engineer:	
Contractor:	
Submitted By:	Date:
Approved By:	Date:

Tag #	Model #	Flow (USGPM)	Head (Feet)	HP	Enclosure TEFC/ODP	Frame	Cycle	Phase	Voltage	RPM
	SCP 8 x 6 x 11 HA						60 Hz	3		

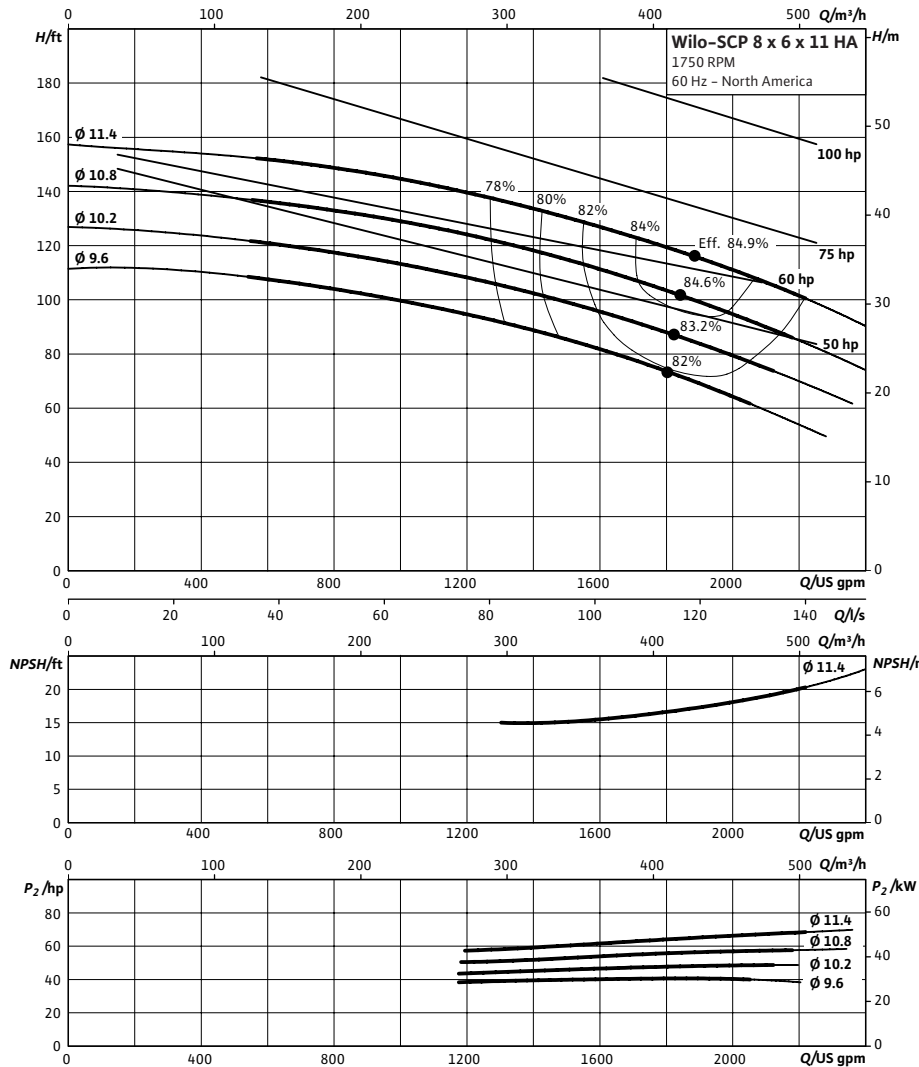

Technical Data

Approved Fluids

Heating Water
Cooling and cold water

Water-Glycol mixtures (for 20–40% glycol and fluid temp ≤ 104°F [40°C])

Fluid Temperature

Mechanical Seal 18°F to 250°F (–8°C to 120°C)
Stuffing Box Packing 18°F to 220°F (–8°C to 105°C)

Materials of Construction

<input type="checkbox"/>	Pump Housing	A48 Class 35
<input type="checkbox"/>	Pump Housing (Optional)	Ni-resist BS 3468 Gr 2 / BS 2789 500.1
<input type="checkbox"/>	Impeller	BS 84 C83 600
<input type="checkbox"/>	Impeller (optional)	A48 Class 35 / BS 84 C83 600
<input type="checkbox"/>	Stationary Wear Rings	BS 84 C93 700
<input type="checkbox"/>	Pump Shaft	A276 type 410
<input type="checkbox"/>	Pump Shaft (optional)	BS 970 316 S16
<input type="checkbox"/>	Mechanical Seal	Carbon/silicon carbide/EPDM (E1)
<input type="checkbox"/>	Other Mechanical Seals	Avail. on request
<input type="checkbox"/>	Additional Spacer Coupling	Avail. on request
<input type="checkbox"/>	Other:	

Approval Stamp

Dimensional Drawing

Single Stage Pump

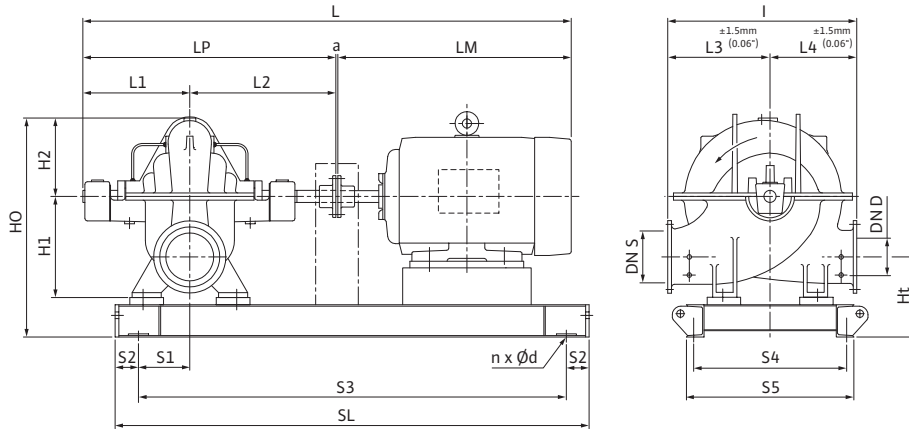

SCP 8 x 6 x 11 HA

Dimensions - Inches (mm)

Frame	a	L	I	L1	L2	L3	L4	LM	LP	H1	H2	HO	Ht	n	Ød	S1	S2	S3	S4	S5	SL	P5	P6
326T	.50 (13)	64.50 (1638)	24.19 (614)	15.63 (397)	18.06 (459)	13.75 (349)	10.44 (265)	30.38 (772)	33.63 (854)	14.94 (379)	10.06 (256)	30.63 (778)	11.94 (303)	4	.91 (23)	3.88 (99)	4.00 (102)	43.81 (1112)	15.19 (386)	17.56 (446)	51.81 (1316)	-	-
364T	.50 (13)	67.13 (1705)	24.19 (614)	15.63 (397)	18.06 (459)	13.75 (349)	10.44 (265)	33.00 (838)	33.63 (854)	14.94 (379)	10.06 (256)	30.63 (778)	11.94 (303)	4	.91 (23)	3.88 (99)	4.00 (102)	45.31 (1151)	15.81 (402)	18.13 (461)	53.31 (1354)	-	-
365T	.50 (13)	67.13 (1705)	24.19 (614)	15.63 (397)	18.06 (459)	13.75 (349)	10.44 (265)	33.00 (838)	33.63 (854)	14.94 (379)	10.06 (256)	30.63 (778)	11.94 (303)	4	.91 (23)	3.88 (99)	4.00 (102)	45.31 (1151)	15.81 (402)	18.13 (461)	53.31 (1354)	-	-
404T	.50 (13)	71.38 (1813)	24.19 (614)	15.63 (397)	18.06 (459)	13.75 (349)	10.44 (265)	37.25 (946)	33.63 (854)	14.94 (379)	10.06 (256)	30.63 (778)	11.94 (303)	4	.91 (23)	3.88 (99)	4.00 (102)	49.25 (1251)	18.50 (470)	20.88 (530)	57.25 (1454)	-	-

Flange Dimensions – Suction Side

Dimensions - Inches (mm)

DN S #125	ØD	Ød	Øk	b	n	D2
8	13.50 (343)	10.63 (270)	11.75 (298)	1.13 (29)	8	.88 (22)

Flange Dimensions – Discharge Side

Dimensions - Inches (mm)

DN D 125#	ØD	Ød	Øk	b	n	D2
6	11.00 (279)	8.50 (216)	9.50 (241)	1.00 (25)	8	.88 (22)

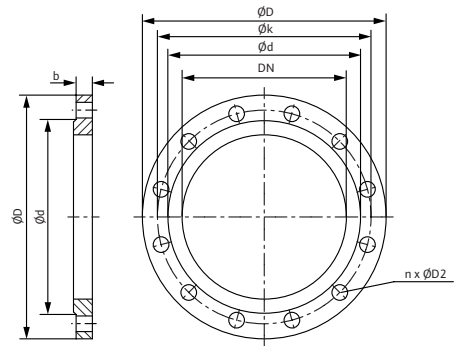

Submittal Data Sheet

Wilo SCP – Horizontal Split Case Pumps



SCP 8 x 6 x 14 HA

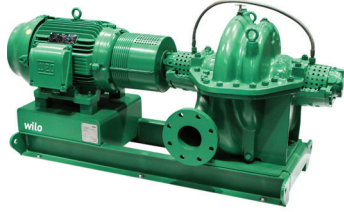

Project:	
Engineer:	
Contractor:	
Submitted By:	Date:
Approved By:	Date:

Tag #	Model #	Flow (USGPM)	Head (Feet)	HP	Enclosure TEFC/ODP	Frame	Cycle	Phase	Voltage	RPM
	SCP 8 x 6 x 14 HA						60 Hz	3		

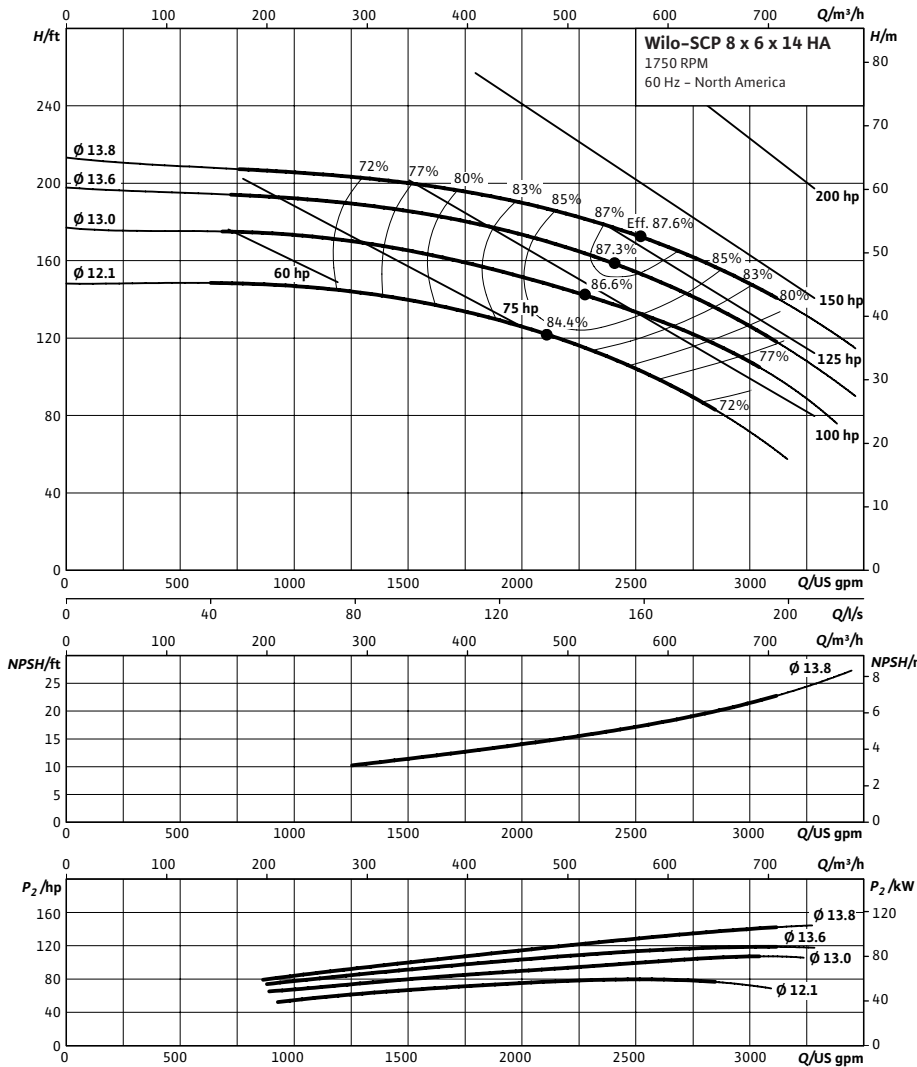

Technical Data

Approved Fluids

Heating Water
Cooling and cold water

Water-Glycol mixtures (for 20–40% glycol and fluid temp ≤ 104°F [40°C])

Fluid Temperature

Mechanical Seal 18°F to 250°F (–8°C to 120°C)
Stuffing Box Packing 18°F to 220°F (–8°C to 105°C)

Materials of Construction

<input type="checkbox"/>	Pump Housing	A48 Class 35
<input type="checkbox"/>	Pump Housing (Optional)	Ni-resist BS 3468 Gr 2 / BS 2789 500.1
<input type="checkbox"/>	Impeller	BS 84 C83 600
<input type="checkbox"/>	Impeller (optional)	A48 Class 35 / BS 84 C83 600
<input type="checkbox"/>	Stationary Wear Rings	BS 84 C93 700
<input type="checkbox"/>	Pump Shaft	A276 type 410
<input type="checkbox"/>	Pump Shaft (optional)	BS 970 316 S16
<input type="checkbox"/>	Mechanical Seal	Carbon/silicon carbide/EPDM (E1)
<input type="checkbox"/>	Other Mechanical Seals	Avail. on request
<input type="checkbox"/>	Additional Spacer Coupling	Avail. on request
<input type="checkbox"/>	Other:	

Approval Stamp

Dimensional Drawing

Single Stage Pump

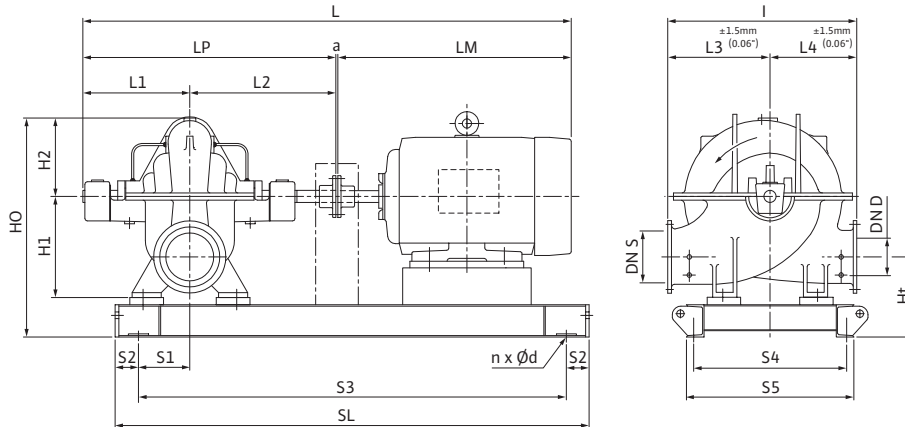

SCP 8 x 6 x 14 HA

Dimensions - Inches (mm)																							
Frame	a	L	I	L1	L2	L3	L4	LM	LP	H1	H2	HO	Ht	n	Ød	S1	S2	S3	S4	S5	SL	P5	P6
364T	.50 (13)	74.63 (1896)	29.50 (749)	19.06 (484)	22.06 (560)	15.75 (400)	13.75 (349)	33.00 (838)	41.13 (1045)	16.75 (425)	10.81 (275)	33.38 (848)	12.63 (321)	4	.91 (23)	6.25 (159)	4.00 (102)	51.69 (1313)	18.94 (481)	21.31 (541)	59.69 (1516)	-	-
365T	.50 (13)	74.63 (1896)	29.50 (749)	19.06 (484)	22.06 (560)	15.75 (400)	13.75 (349)	33.00 (838)	41.13 (1045)	16.75 (425)	10.81 (275)	33.38 (848)	12.63 (321)	4	.91 (23)	6.25 (159)	4.00 (102)	51.69 (1313)	18.94 (481)	21.31 (541)	59.69 (1516)	-	-
404T	.50 (13)	78.81 (2002)	29.50 (749)	19.06 (484)	22.06 (560)	15.75 (400)	13.75 (349)	37.25 (946)	41.13 (1045)	16.75 (425)	10.81 (275)	33.38 (848)	12.63 (321)	4	.91 (23)	6.25 (159)	4.00 (102)	55.63 (1413)	18.94 (481)	21.31 (541)	63.63 (1616)	-	-
405T	.50 (13)	85.88 (2181)	29.50 (749)	19.06 (484)	22.06 (560)	15.75 (400)	13.75 (349)	44.25 (1124)	41.13 (1045)	16.75 (425)	10.81 (275)	33.38 (848)	12.63 (321)	4	.91 (23)	6.25 (159)	4.00 (102)	55.63 (1413)	18.94 (481)	21.31 (541)	63.63 (1616)	-	-
444T	.50 (13)	85.88 (2181)	29.50 (749)	19.06 (484)	22.06 (560)	15.75 (400)	13.75 (349)	44.25 (1124)	41.13 (1045)	16.75 (425)	10.81 (275)	33.38 (848)	12.63 (321)	4	.91 (23)	6.25 (159)	4.00 (102)	60.81 (1545)	21.56 (548)	23.88 (607)	68.81 (1748)	-	-
445T	.50 (13)	85.88 (2181)	29.50 (749)	19.06 (484)	22.06 (560)	15.75 (400)	13.75 (349)	44.25 (1124)	41.13 (1045)	16.75 (425)	10.81 (275)	33.38 (848)	12.63 (321)	4	.91 (23)	6.25 (159)	4.00 (102)	60.81 (1545)	21.56 (548)	23.88 (607)	68.81 (1748)	-	-

Flange Dimensions – Suction Side

Dimensions - Inches (mm)						
DN S #125	ØD	Ød	Øk	b	n	D2
8	13.50 (343)	10.63 (270)	11.75 (298)	1.13 (29)	8	.88 (22)

Flange Dimensions – Discharge Side

Dimensions - Inches (mm)						
DN D 125#	ØD	Ød	Øk	b	n	D2
6	11.00 (279)	8.50 (216)	9.50 (241)	1.00 (25)	8	.88 (22)

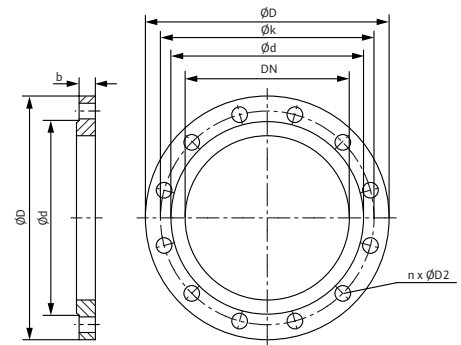

Submittal Data Sheet

Wilo SCP – Horizontal Split Case Pumps



SCP 8 x 6 x 15 HA

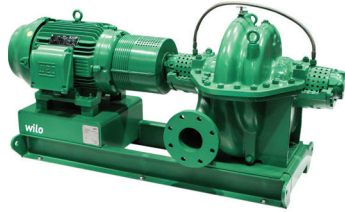

Project:										
Engineer:										
Contractor:										
Submitted By:							Date:			
Approved By:							Date:			

Tag #	Model #	Flow (USGPM)	Head (Feet)	HP	Enclosure TEFC/ODP	Frame	Cycle	Phase	Voltage	RPM
	SCP 8 x 6 x 15 HA						60 Hz	3		

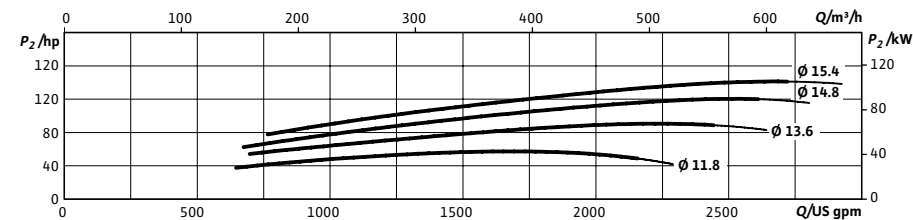
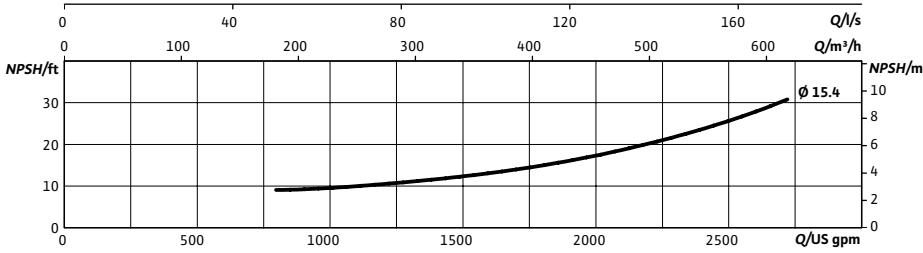
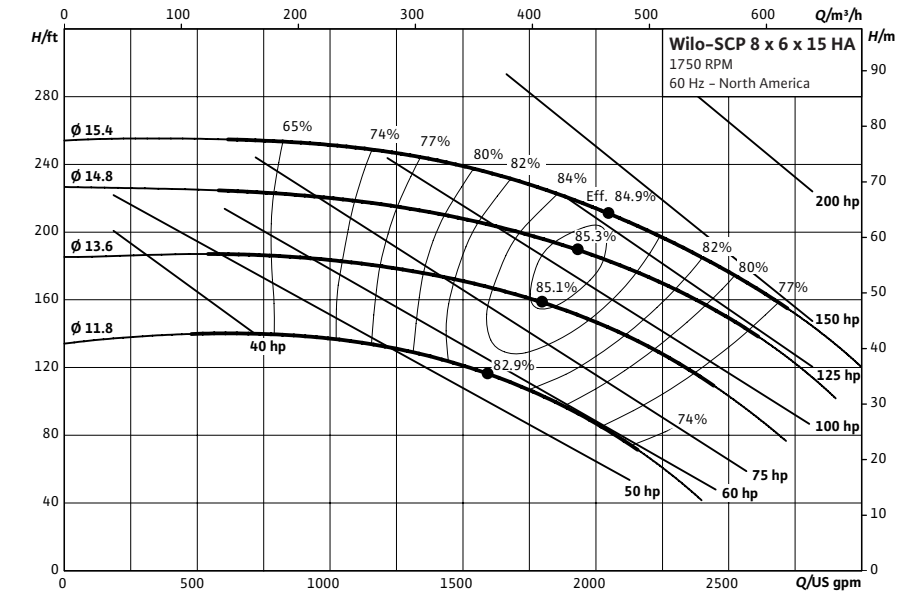

Technical Data

Approved Fluids

Heating Water
Cooling and cold water

Water-Glycol mixtures (for 20-40% glycol and fluid temp ≤ 104°F [40°C])

Fluid Temperature

Mechanical Seal 18°F to 250°F (-8°C to 120°C)
Stuffing Box Packing 18°F to 220°F (-8°C to 105°C)

Materials of Construction

<input type="checkbox"/> Pump Housing	A48 Class 35
<input type="checkbox"/> Pump Housing (Optional)	Ni-resist BS 3468 Gr 2 / BS 2789 500.1
<input type="checkbox"/> Impeller	BS 84 C83 600
<input type="checkbox"/> Impeller (optional)	A48 Class 35 / BS 84 C83 600
<input type="checkbox"/> Stationary Wear Rings	BS 84 C93 700
<input type="checkbox"/> Pump Shaft	A276 type 410
<input type="checkbox"/> Pump Shaft (optional)	BS 970 316 S16
<input type="checkbox"/> Mechanical Seal	Carbon/silicon carbide/EPDM (E1)
<input type="checkbox"/> Other Mechanical Seals	Avail. on request
<input type="checkbox"/> Additional Spacer Coupling	Avail. on request
<input type="checkbox"/> Other:	

Approval Stamp

Dimensional Drawing

Single Stage Pump

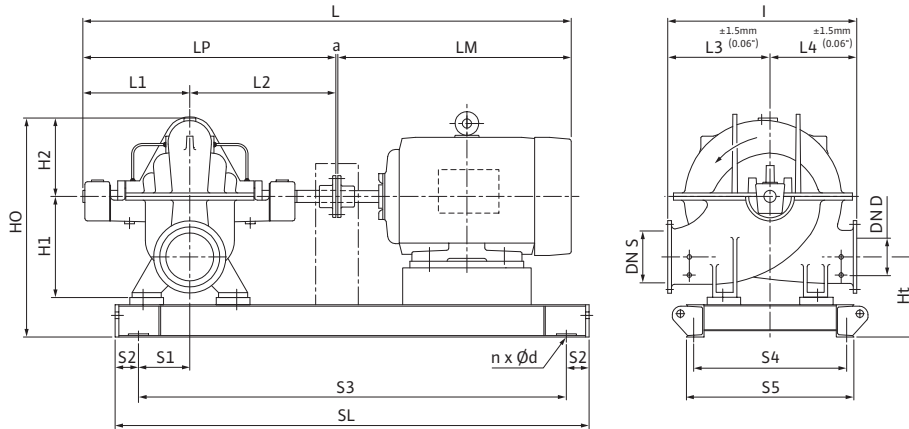

SCP 8 x 6 x 15 HA

Dimensions - Inches (mm)

Frame	a	L	I	L1	L2	L3	L4	LM	LP	H1	H2	HO	Ht	n	Ød	S1	S2	S3	S4	S5	SL	P5	P6
324T	.50 (13)	65.75 (1670)	29.00 (737)	16.19 (411)	18.69 (475)	16.00 (406)	13.00 (330)	30.38 (772)	34.81 (884)	13.50 (343)	11.00 (279)	30.38 (772)	10.31 (262)	4	.91 (23)	6.25 (159)	4.00 (102)	46.81 (1189)	17.38 (441)	19.75 (502)	54.81 (1392)	-	-
325T	.50 (13)	65.75 (1670)	29.00 (737)	16.19 (411)	18.69 (475)	16.00 (406)	13.00 (330)	30.38 (772)	34.81 (884)	13.50 (343)	11.00 (279)	30.38 (772)	10.31 (262)	4	.91 (23)	6.25 (159)	4.00 (102)	46.81 (1189)	17.38 (441)	19.75 (502)	54.81 (1392)	-	-
364T	.50 (13)	68.38 (1737)	29.00 (737)	16.19 (411)	18.69 (475)	16.00 (406)	13.00 (330)	33.00 (838)	34.81 (884)	13.50 (343)	11.00 (279)	30.38 (772)	10.31 (262)	4	.91 (23)	6.25 (159)	4.00 (102)	48.31 (1227)	17.38 (441)	19.75 (502)	56.31 (1430)	-	-
365T	.50 (13)	68.38 (1737)	29.00 (737)	16.19 (411)	18.69 (475)	16.00 (406)	13.00 (330)	33.00 (838)	34.81 (884)	13.50 (343)	11.00 (279)	30.38 (772)	10.31 (262)	4	.91 (23)	6.25 (159)	4.00 (102)	48.31 (1227)	17.38 (441)	19.75 (502)	56.31 (1430)	-	-
404T	.50 (13)	72.56 (1843)	29.00 (737)	16.19 (411)	18.69 (475)	16.00 (406)	13.00 (330)	37.25 (946)	34.81 (884)	13.50 (343)	11.00 (279)	30.38 (772)	10.31 (262)	4	.91 (23)	6.25 (159)	4.00 (102)	52.25 (1327)	18.50 (470)	20.88 (531)	60.25 (1530)	-	-
405T	.50 (13)	79.56 (2021)	29.00 (737)	16.19 (411)	18.69 (475)	16.00 (406)	13.00 (330)	44.25 (1124)	34.81 (884)	13.50 (343)	11.00 (279)	30.38 (772)	10.31 (262)	4	.91 (23)	6.25 (159)	4.00 (102)	52.25 (1327)	18.50 (470)	20.88 (531)	60.25 (1530)	-	-
444T	.50 (13)	79.56 (2021)	29.00 (737)	16.19 (411)	18.69 (475)	16.00 (406)	13.00 (330)	44.25 (1124)	34.81 (884)	13.50 (343)	11.00 (279)	30.38 (772)	10.31 (262)	4	.91 (23)	6.25 (159)	4.00 (102)	57.38 (1457)	21.56 (548)	23.88 (607)	65.38 (1661)	-	-
445T	.50 (13)	79.56 (2021)	29.00 (737)	16.19 (411)	18.69 (475)	16.00 (406)	13.00 (330)	44.25 (1124)	34.81 (884)	13.50 (343)	11.00 (279)	30.38 (772)	10.31 (262)	4	.91 (23)	6.25 (159)	4.00 (102)	47.19 (1199)	21.56 (548)	23.88 (607)	55.19 (1402)	-	-

Flange Dimensions – Suction Side

Dimensions - Inches (mm)

DN S #125	ØD	Ød	Øk	b	n	D2
8	13.50 (343)	10.63 (270)	11.75 (298)	1.13 (29)	8	.88 (22)

Flange Dimensions – Discharge Side

Dimensions - Inches (mm)

DN D 125#	ØD	Ød	Øk	b	n	D2
6	11.00 (279)	8.50 (216)	9.50 (241)	1.00 (25)	8	.88 (22)

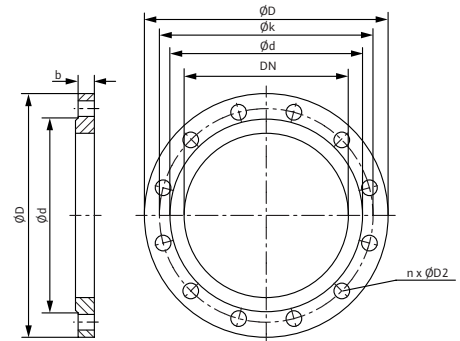

Submittal Data Sheet

Wilo SCP – Horizontal Split Case Pumps



SCP 8 x 6 x 17 HA

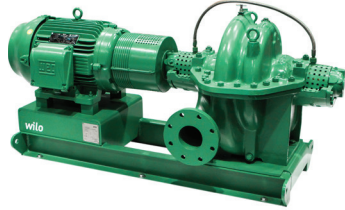

Project:										
Engineer:										
Contractor:										
Submitted By:							Date:			
Approved By:							Date:			

Tag #	Model #	Flow (USGPM)	Head (Feet)	HP	Enclosure TEFC/ODP	Frame	Cycle	Phase	Voltage	RPM
	SCP 8 x 6 x 17 HA						60 Hz	3		

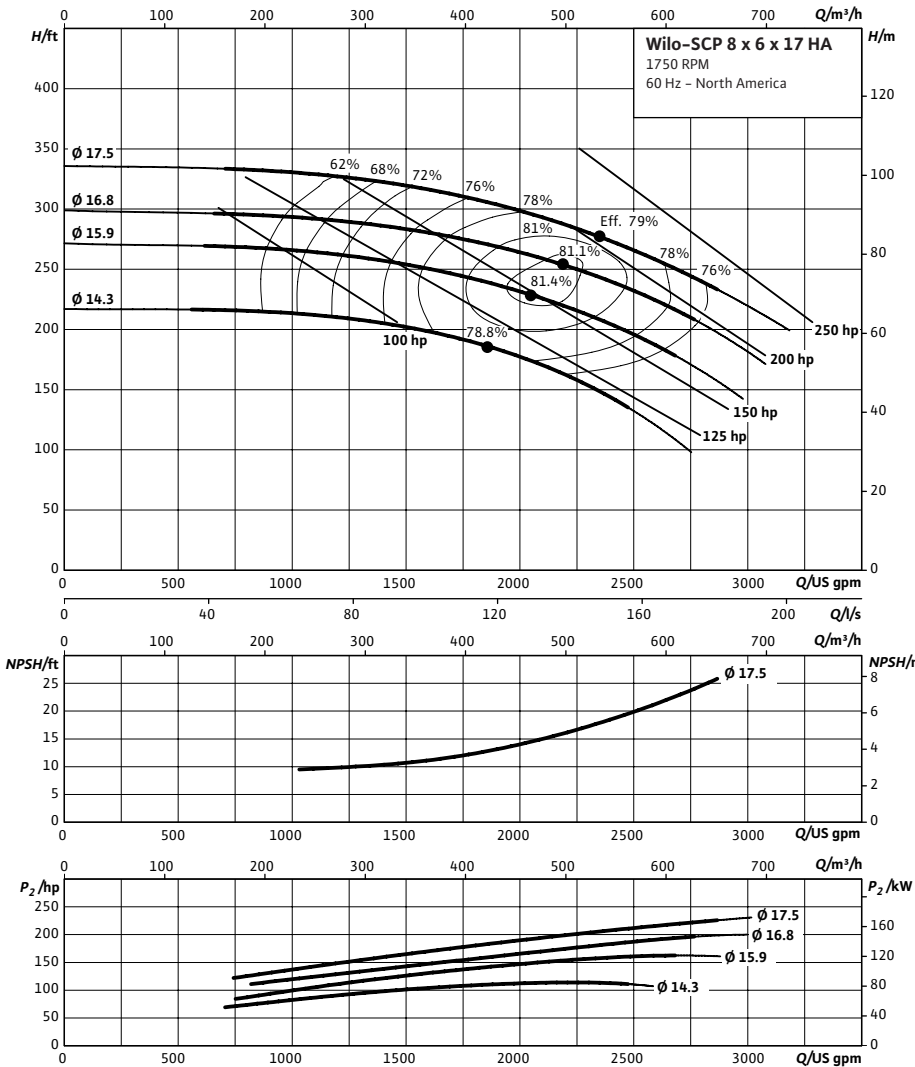

Technical Data

Approved Fluids
 Heating Water
 Cooling and cold water
 Water-Glycol mixtures (for 20-40% glycol and fluid temp ≤ 104°F [40°C])

Fluid Temperature
 Mechanical Seal: 18°F to 250°F (-8°C to 120°C)
 Stuffing Box Packing: 18°F to 220°F (-8°C to 105°C)

Materials of Construction

<input type="checkbox"/> Pump Housing	A48 Class 35
<input type="checkbox"/> Pump Housing (Optional)	Ni-resist BS 3468 Gr 2 / BS 2789 500.1
<input type="checkbox"/> Impeller	BS 84 C83 600
<input type="checkbox"/> Impeller (optional)	A48 Class 35 / BS 84 C83 600
<input type="checkbox"/> Stationary Wear Rings	BS 84 C93 700
<input type="checkbox"/> Pump Shaft	A276 type 410
<input type="checkbox"/> Pump Shaft (optional)	BS 970 316 S16
<input type="checkbox"/> Mechanical Seal	Carbon/silicon carbide/EPDM (E1)
<input type="checkbox"/> Other Mechanical Seals	Avail. on request
<input type="checkbox"/> Additional Spacer Coupling	Avail. on request
<input type="checkbox"/> Other:	

Approval Stamp

Dimensional Drawing

Single Stage Pump

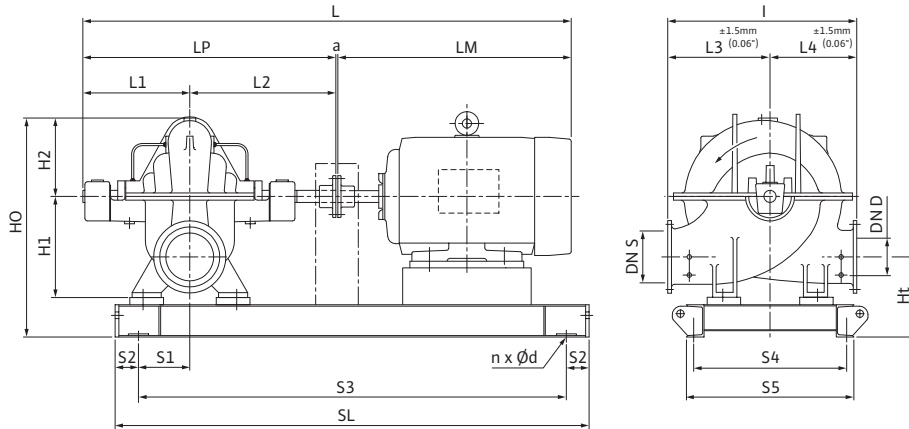

SCP 8 x 6 x 17 HA

Dimensions - Inches (mm)

Frame	a	L	I	L1	L2	L3	L4	LM	LP	H1	H2	HO	Ht	n	Ød	S1	S2	S3	S4	S5	SL	P5	P6
404T	.50 (13)	72.56 (1843)	32.00 (813)	16.19 (411)	18.69 (475)	17.00 (432)	15.00 (381)	37.25 (946)	34.81 (884)	16.75 (425)	12.00 (305)	39.56 (878)	11.75 (298)	4	.91 (23)	6.25 (159)	4.00 (102)	52.25 (1327)	18.50 (470)	20.88 (531)	60.25 (1530)	-	-
405T	.50 (13)	79.56 (2021)	32.00 (813)	16.19 (411)	18.69 (475)	17.00 (432)	15.00 (381)	44.25 (1124)	34.81 (884)	16.75 (425)	12.00 (305)	39.56 (878)	11.75 (298)	4	.91 (23)	6.25 (159)	4.00 (102)	52.25 (1327)	18.50 (470)	20.88 (531)	60.25 (1530)	-	-
444T	.50 (13)	79.56 (2021)	32.00 (813)	16.19 (411)	18.69 (475)	17.00 (432)	15.00 (381)	44.25 (1124)	34.81 (884)	16.75 (425)	12.00 (305)	39.56 (878)	11.75 (298)	4	.91 (23)	6.25 (159)	4.00 (102)	57.38 (1457)	21.56 (548)	23.88 (607)	65.38 (1661)	-	-
445T / 200 hp	.50 (13)	79.56 (2021)	32.00 (813)	16.19 (411)	18.69 (475)	17.00 (432)	15.00 (381)	44.25 (1124)	34.81 (884)	16.75 (425)	12.00 (305)	39.56 (878)	11.75 (298)	4	.91 (23)	6.25 (159)	4.00 (102)	57.38 (1457)	21.56 (548)	23.88 (607)	65.38 (1661)	-	-
445T / 250 hp	.19 (5)	82.81 (2103)	32.00 (813)	16.19 (411)	18.69 (475)	17.00 (432)	15.00 (381)	47.75 (1213)	34.81 (884)	16.75 (425)	12.00 (305)	39.56 (878)	11.75 (298)	4	.91 (23)	6.25 (159)	4.00 (102)	58.13 (1477)	21.56 (548)	23.88 (607)	66.13 (1680)	-	-

Flange Dimensions – Suction Side

Dimensions - Inches (mm)

DN S #125	ØD	Ød	Øk	b	n	D2
8	13.50 (343)	10.63 (270)	11.75 (298)	1.13 (29)	8	.88 (22)

Flange Dimensions – Discharge Side

Dimensions - Inches (mm)

DN D 125#	ØD	Ød	Øk	b	n	D2
6	11.00 (279)	8.50 (216)	9.50 (241)	1.00 (25)	8	.88 (22)

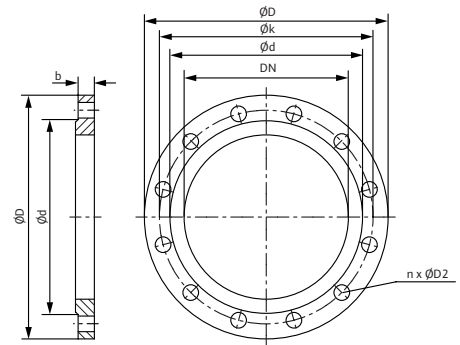

Submittal Data Sheet

Wilo SCP – Horizontal Split Case Pumps



SCP 8 x 6 x 18 DS

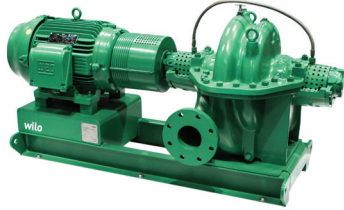

Project:	
Engineer:	
Contractor:	
Submitted By:	Date:
Approved By:	Date:

Tag #	Model #	Flow (USGPM)	Head (Feet)	HP	Enclosure TEFC/ODP	Frame	Cycle	Phase	Voltage	RPM
	SCP 8 x 6 x 18 DS						60 Hz	3		

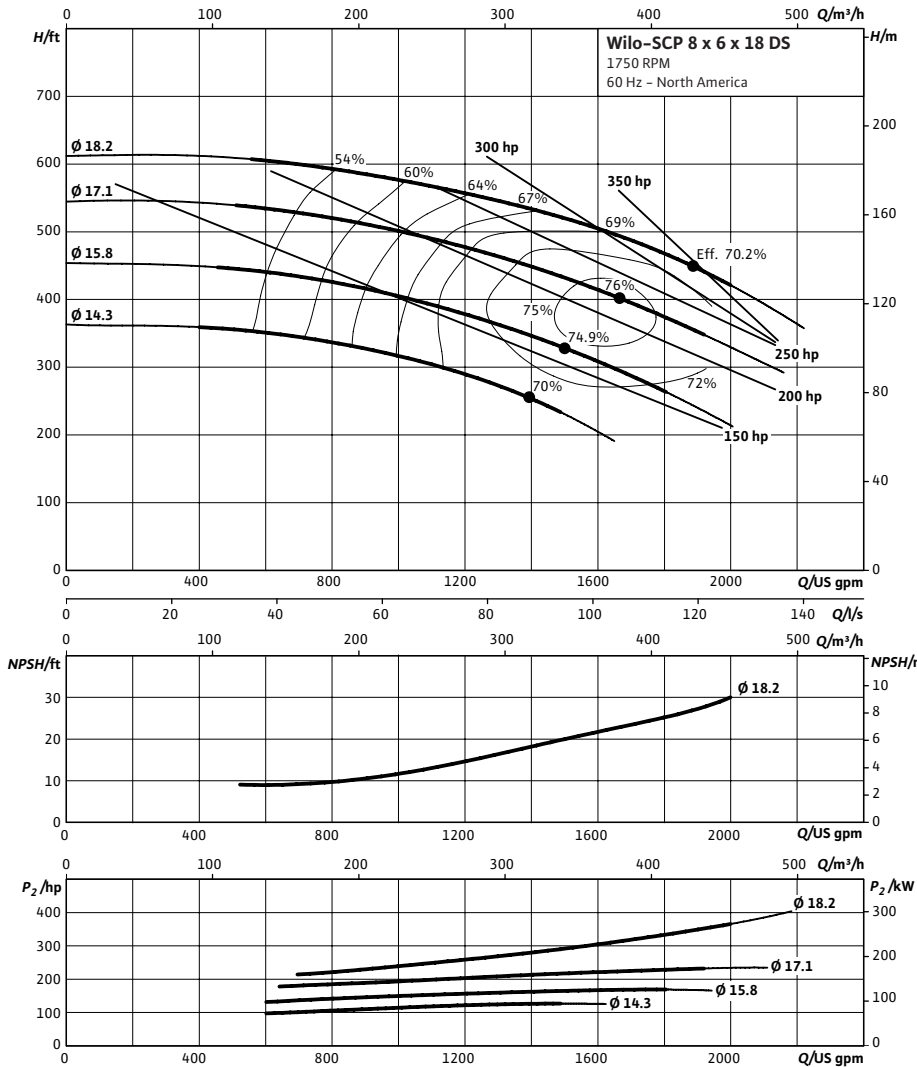

Technical Data

Approved Fluids

Heating Water
Cooling and cold water

Water-Glycol mixtures (for 20–40% glycol and fluid temp ≤ 104°F [40°C])

Fluid Temperature

Mechanical Seal: 18°F to 250°F (–8°C to 120°C)
Stuffing Box Packing: 18°F to 220°F (–8°C to 105°C)

Materials of Construction

<input type="checkbox"/>	Pump Housing	A48 Class 35
<input type="checkbox"/>	Pump Housing (Optional)	Ni-resist BS 3468 Gr 2 / BS 2789 500.1
<input type="checkbox"/>	Impeller	BS 84 C83 600
<input type="checkbox"/>	Impeller (optional)	A48 Class 35 / BS 84 C83 600
<input type="checkbox"/>	Stationary Wear Rings	BS 84 C93 700
<input type="checkbox"/>	Pump Shaft	A276 type 410
<input type="checkbox"/>	Pump Shaft (optional)	BS 970 316 S16
<input type="checkbox"/>	Mechanical Seal	Carbon/silicon carbide/EPDM (E1)
<input type="checkbox"/>	Other Mechanical Seals	Avail. on request
<input type="checkbox"/>	Additional Spacer Coupling	Avail. on request
<input type="checkbox"/>	Other:	

Approval Stamp

Dimensional Drawing

Dual Stage Pump

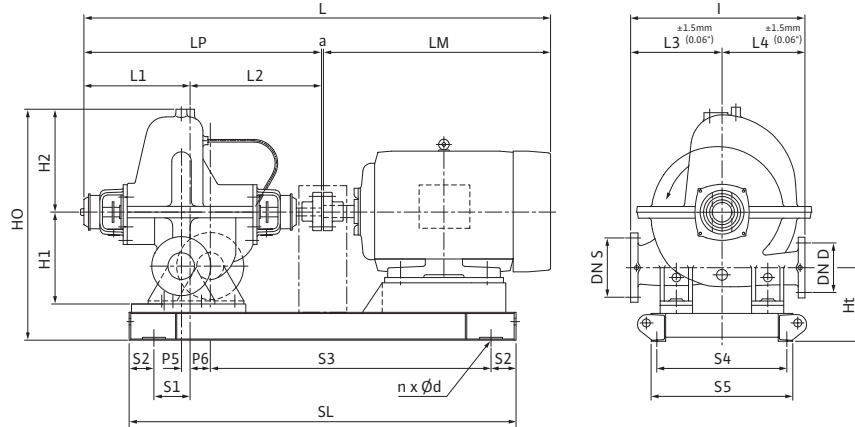

SCP 8 x 6 x 18 DS

Dimensions – Inches (mm)

Frame	a	L	I	L1	L2	L3	L4	LM	LP	H1	H2	HO	Ht	n	Ød	S1	S2	S3	S4	S5	SL	P5	P6
364T	.50 (13)	92.75 (2356)	30.31 (770)	21.88 (556)	26.19 (665)	17.31 (440)	13.00 (330)	44.25 (1124)	48.00 (1219)	18.50 (470)	12.50 (318)	36.81 (935)	14.50 (368)	4	.91 (23)	8.38 (213)	4.00 (102)	67.06 (1703)	21.56 (548)	23.88 (607)	75.06 (1907)	2.75 (70)	8.25 (210)
404T	.50 (13)	92.75 (2356)	30.31 (770)	21.88 (556)	26.19 (665)	17.31 (440)	13.00 (330)	44.25 (1124)	48.00 (1219)	18.50 (470)	12.50 (318)	36.81 (935)	14.50 (368)	4	.91 (23)	8.38 (213)	4.00 (102)	67.06 (1703)	21.56 (548)	23.88 (607)	75.06 (1907)	2.75 (70)	8.25 (210)
405T	.19 (5)	96.00 (2438)	30.31 (770)	21.88 (556)	26.19 (665)	17.31 (440)	13.00 (330)	47.75 (1213)	48.00 (1219)	18.50 (470)	12.50 (318)	36.81 (935)	14.50 (368)	4	.91 (23)	8.38 (213)	4.00 (102)	67.75 (1721)	21.56 (548)	23.88 (607)	75.75 (1924)	2.75 (70)	8.25 (210)
444T	.19 (5)	101.63 (2581)	30.31 (770)	21.88 (556)	26.19 (665)	17.31 (440)	13.00 (330)	53.38 (1356)	48.00 (1219)	18.50 (470)	12.50 (318)	36.81 (935)	14.50 (368)	4	.91 (23)	8.38 (213)	4.00 (102)	67.75 (1721)	21.56 (548)	23.88 (607)	75.75 (1924)	2.75 (70)	8.25 (210)
445T	.19 (5)	101.63 (2581)	30.31 (770)	21.88 (556)	26.19 (665)	17.31 (440)	13.00 (330)	53.38 (1356)	48.00 (1219)	18.50 (470)	12.50 (318)	36.81 (935)	14.50 (368)	4	.91 (23)	8.38 (213)	4.00 (102)	76.00 (1930)	21.06 (535)	23.38 (594)	84.00 (2134)	2.75 (70)	8.25 (210)

Flange Dimensions – Suction Side

Dimensions – Inches (mm)

DN S #125	ØD	Ød	Øk	b	n	D2
8	13.50 (343)	10.63 (270)	11.75 (298)	1.13 (29)	8	.88 (22)

Flange Dimensions – Discharge Side

Dimensions – Inches (mm)

DN D 125#	ØD	Ød	Øk	b	n	D2
6	11.00 (279)	8.50 (216)	9.50 (241)	1.00 (25)	8	.88 (22)

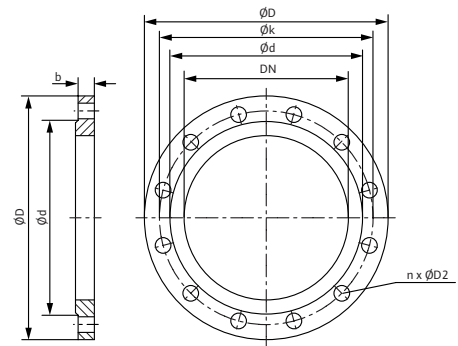

Submittal Data Sheet

Wilco SCP - Horizontal Split Case Pumps



SCP 8 x 6 x 20½ HA

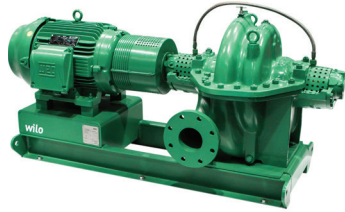

Project:	
Engineer:	
Contractor:	
Submitted By:	Date:
Approved By:	Date:

Tag #	Model #	Flow (USGPM)	Head (Feet)	HP	Enclosure TEFC/ODP	Frame	Cycle	Phase	Voltage	RPM
	SCP 8 x 6 x 20½ HA						60 Hz	3		

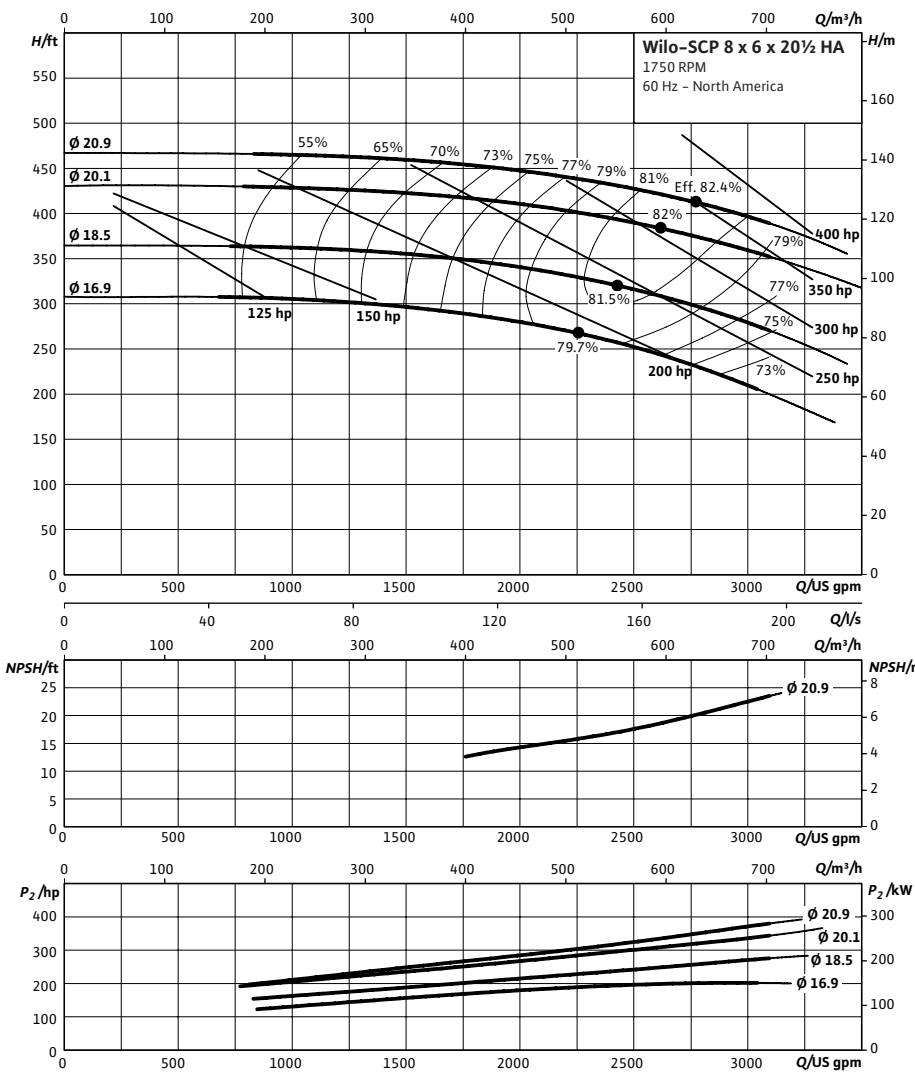

Technical Data

Approved Fluids	
Heating Water	
Cooling and cold water	
Water-Glycol mixtures (for 20-40% glycol and fluid temp ≤ 104°F [40°C])	
Fluid Temperature	
Mechanical Seal	18°F to 250°F (-8°C to 120°C)
Stuffing Box Packing	18°F to 220°F (-8°C to 105°C)

Materials of Construction

<input type="checkbox"/> Pump Housing	A48 Class 35
<input type="checkbox"/> Pump Housing (Optional)	Ni-resist BS 3468 Gr 2 / BS 2789 500.1
<input type="checkbox"/> Impeller	BS 84 C83 600
<input type="checkbox"/> Impeller (optional)	A48 Class 35 / BS 84 C83 600
<input type="checkbox"/> Stationary Wear Rings	BS 84 C93 700
<input type="checkbox"/> Pump Shaft	A276 type 410
<input type="checkbox"/> Pump Shaft (optional)	BS 970 316 S16
<input type="checkbox"/> Mechanical Seal	Carbon/silicon carbide/EPDM (E1)
<input type="checkbox"/> Other Mechanical Seals	Avail. on request
<input type="checkbox"/> Additional Spacer Coupling	Avail. on request
<input type="checkbox"/> Other:	

Approval Stamp

Dimensional Drawing

Single Stage Pump

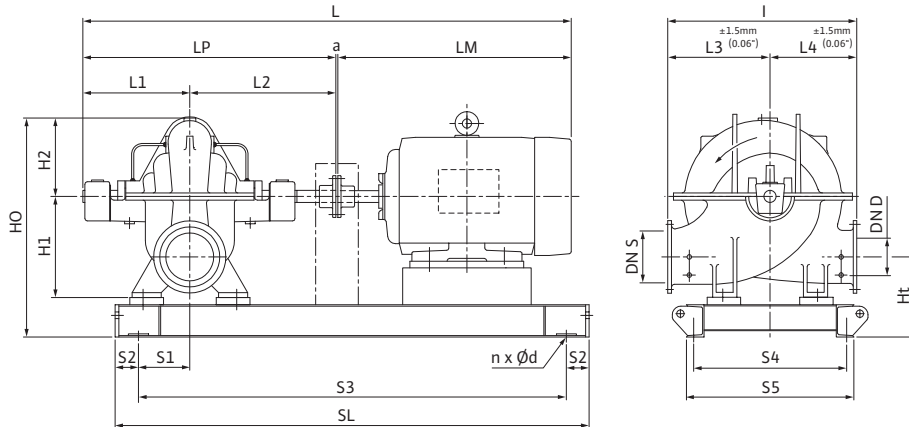

SCP 8 x 6 x 20½ HA

Dimensions - Inches (mm)

Frame	a	L	I	L1	L2	L3	L4	LM	LP	H1	H2	HO	Ht	n	Ød	S1	S2	S3	S4	S5	SL	P5	P6
405T	.50 (13)	89.13 (2264)	35.06 (891)	19.88 (505)	24.50 (622)	17.69 (449)	17.31 (440)	44.25 (1124)	44.38 (1127)	18.31 (465)	14.56 (370)	38.81 (986)	11.63 (295)	4	.91 (23)	8.19 (208)	4.00 (102)	60.06 (1526)	21.69 (551)	24.06 (611)	68.06 (1729)	-	-
444T	.50 (13)	89.13 (2264)	35.06 (891)	19.88 (505)	24.50 (622)	17.69 (449)	17.31 (440)	44.25 (1124)	44.38 (1127)	18.31 (465)	14.56 (370)	38.81 (986)	11.63 (295)	4	.91 (23)	8.19 (208)	4.00 (102)	53.19 (1356)	21.69 (551)	24.06 (611)	73.19 (1859)	-	-
445T/ 200 hp	.50 (13)	89.13 (2264)	35.06 (891)	19.88 (505)	24.50 (622)	17.69 (449)	17.31 (440)	44.25 (1124)	44.38 (1127)	18.31 (465)	14.56 (370)	38.81 (986)	11.63 (295)	4	.91 (23)	8.19 (208)	4.00 (102)	53.19 (1356)	21.69 (551)	24.06 (611)	73.19 (1859)	-	-
445T/ 250 hp	.19 (5)	95.31 (2345)	35.06 (891)	19.88 (505)	24.50 (622)	17.69 (449)	17.31 (440)	47.75 (1213)	44.38 (1127)	18.31 (465)	14.56 (370)	38.81 (986)	11.63 (295)	4	.91 (23)	8.19 (208)	4.00 (102)	65.94 (1675)	21.69 (551)	24.06 (611)	73.19 (1859)	-	-
445T/ 300 hp	.19 (5)	98.00 (2489)	35.06 (891)	19.88 (505)	24.50 (622)	17.69 (449)	17.31 (440)	53.38 (1356)	44.38 (1127)	18.31 (465)	14.56 (370)	38.81 (986)	11.63 (295)	4	.91 (23)	8.19 (208)	4.00 (102)	65.94 (1675)	21.69 (551)	24.06 (611)	73.19 (1859)	-	-
449T/ 350 hp	.19 (5)	98.00 (2489)	35.06 (891)	19.88 (505)	24.50 (622)	17.69 (449)	17.31 (440)	53.38 (1356)	44.38 (1127)	18.31 (465)	14.56 (370)	38.81 (986)	11.63 (295)	4	.91 (23)	8.19 (208)	4.00 (102)	74.19 (1884)	21.69 (551)	24.06 (611)	82.19 (2088)	-	-
449T/ 400 hp	.19 (5)	98.00 (2489)	35.06 (891)	19.88 (505)	24.50 (622)	17.69 (449)	17.31 (440)	53.38 (1356)	44.38 (1127)	18.31 (465)	14.56 (370)	38.81 (986)	11.63 (295)	4	.91 (23)	8.19 (208)	4.00 (102)	74.19 (1884)	21.69 (551)	24.06 (611)	82.19 (2088)	-	-

Flange Dimensions – Suction Side

Dimensions - Inches (mm)

DN S #125	ØD	Ød	Øk	b	n	D2
8	13.50 (343)	10.63 (270)	11.75 (298)	1.13 (29)	8	.88 (22)

Flange Dimensions – Discharge Side

Dimensions - Inches (mm)

DND 125#	ØD	Ød	Øk	b	n	D2
6	11.00 (279)	8.50 (216)	9.50 (241)	1.00 (25)	8	.88 (22)

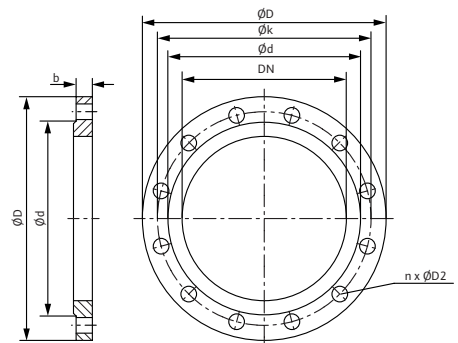

Submittal Data Sheet

Wilo SCP – Horizontal Split Case Pumps



SCP 8 x 8 x 12 HA

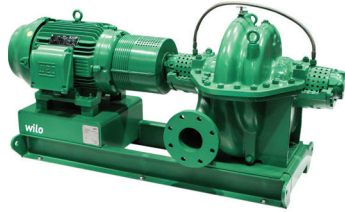

Project:	
Engineer:	
Contractor:	
Submitted By:	Date:
Approved By:	Date:

Tag #	Model #	Flow (USGPM)	Head (Feet)	HP	Enclosure TEFC/ODP	Frame	Cycle	Phase	Voltage	RPM
	SCP 8 x 8 x 12 HA						60 Hz	3		

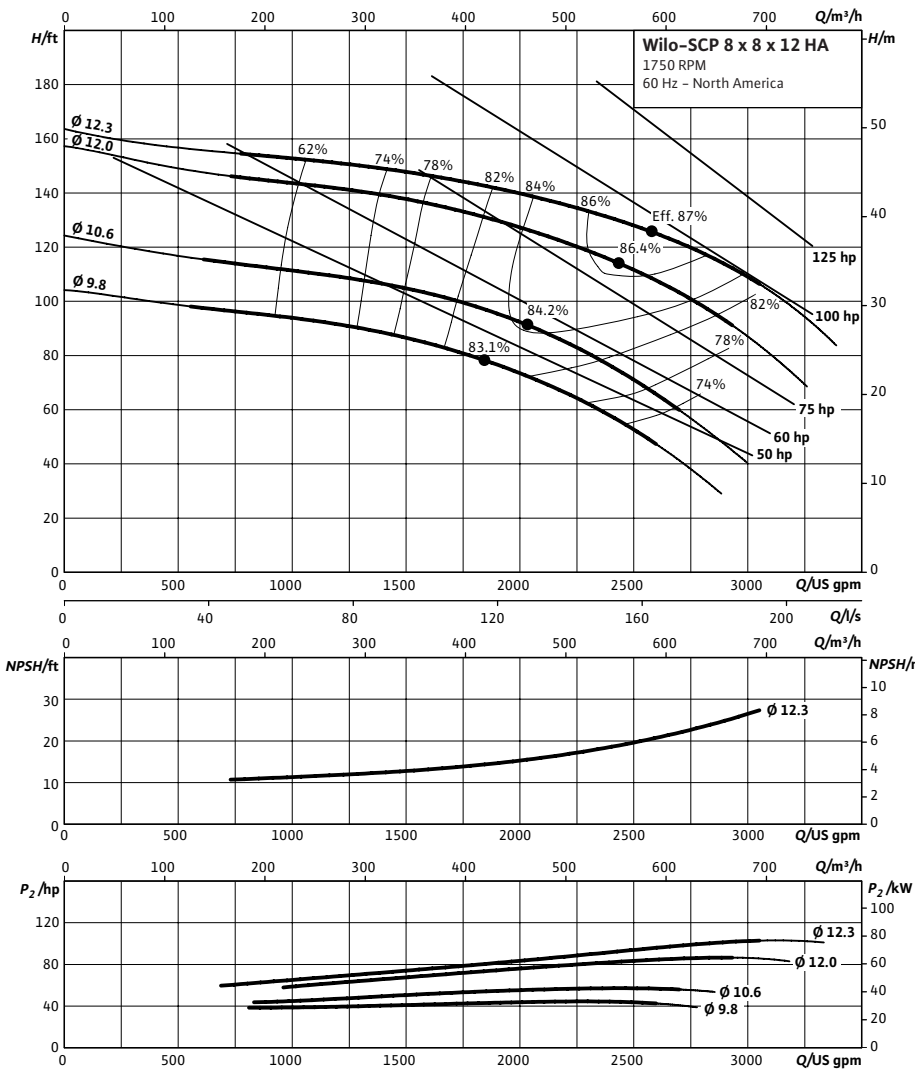

Technical Data

Approved Fluids
 Heating Water
 Cooling and cold water
 Water-Glycol mixtures (for 20-40% glycol and fluid temp ≤ 104°F [40°C])

Fluid Temperature
 Mechanical Seal: 18°F to 250°F (-8°C to 120°C)
 Stuffing Box Packing: 18°F to 220°F (-8°C to 105°C)

Materials of Construction

<input type="checkbox"/> Pump Housing	A48 Class 35
<input type="checkbox"/> Pump Housing (Optional)	Ni-resist BS 3468 Gr 2 / BS 2789 500.1
<input type="checkbox"/> Impeller	BS 84 C83 600
<input type="checkbox"/> Impeller (optional)	A48 Class 35 / BS 84 C83 600
<input type="checkbox"/> Stationary Wear Rings	BS 84 C93 700
<input type="checkbox"/> Pump Shaft	A276 type 410
<input type="checkbox"/> Pump Shaft (optional)	BS 970 316 S16
<input type="checkbox"/> Mechanical Seal	Carbon/silicon carbide/EPDM (E1)
<input type="checkbox"/> Other Mechanical Seals	Avail. on request
<input type="checkbox"/> Additional Spacer Coupling	Avail. on request
<input type="checkbox"/> Other:	

Approval Stamp

Dimensional Drawing

Single Stage Pump

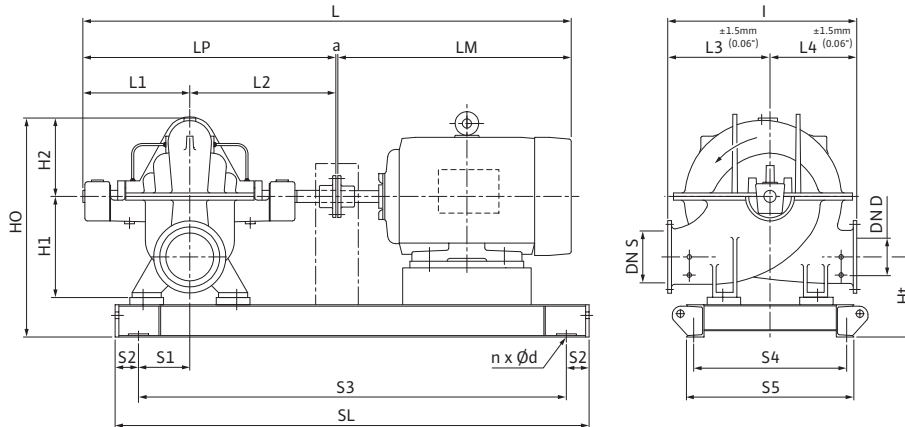

SCP 8 x 8 x 12 HA

Dimensions - Inches (mm)

Frame	a	L	I	L1	L2	L3	L4	LM	LP	H1	H2	HO	Ht	n	Ød	S1	S2	S3	S4	S5	SL	P5	P6
326T	.50 (13)	65.75 (1651)	28.50 (724)	16.19 (411)	18.69 (475)	16.00 (406)	12.50 (318)	30.38 (772)	34.81 (884)	13.50 (343)	10.63 (270)	29.94 (761)	10.38 (264)	4	.91 (23)	6.25 (159)	4.00 (102)	46.81 (1189)	17.38 (441)	19.75 (502)	54.81 (1392)	-	-
364T	.50 (13)	68.38 (1737)	28.50 (724)	16.19 (411)	18.69 (475)	16.00 (406)	12.50 (318)	33.00 (838)	34.81 (884)	13.50 (343)	10.63 (270)	29.94 (761)	10.38 (264)	4	.91 (23)	6.25 (159)	4.00 (102)	48.31 (1227)	17.38 (441)	19.75 (502)	56.31 (1430)	-	-
365T	.50 (13)	68.38 (1737)	28.50 (724)	16.19 (411)	18.69 (475)	16.00 (406)	12.50 (318)	33.00 (838)	34.81 (884)	13.50 (343)	10.63 (270)	29.94 (761)	10.38 (264)	4	.91 (23)	6.25 (159)	4.00 (102)	48.31 (1227)	17.38 (441)	19.75 (502)	56.31 (1430)	-	-
404T	.50 (13)	72.56 (1843)	28.50 (724)	16.19 (411)	18.69 (475)	16.00 (406)	12.50 (318)	37.25 (946)	34.81 (884)	13.50 (343)	10.63 (270)	29.94 (761)	10.38 (264)	4	.91 (23)	6.25 (159)	4.00 (102)	52.25 (1327)	18.50 (470)	20.88 (530)	60.25 (1530)	-	-
405T	.50 (13)	72.56 (1843)	28.50 (724)	16.19 (411)	18.69 (475)	16.00 (406)	12.50 (318)	44.25 (1124)	34.81 (884)	13.50 (343)	10.63 (270)	29.94 (761)	10.38 (264)	4	.91 (23)	6.25 (159)	4.00 (102)	52.25 (1327)	18.50 (470)	20.88 (530)	60.25 (1530)	-	-

Flange Dimensions – Suction Side

Dimensions - Inches (mm)

DN S #125	ØD	Ød	Øk	b	n	D2
8	13.50 (343)	10.63 (270)	11.75 (298)	1.13 (29)	8	.88 (22)

Flange Dimensions – Discharge Side

Dimensions - Inches (mm)

DN D 125#	ØD	Ød	Øk	b	n	D2
8	13.50 (343)	10.63 (270)	11.75 (298)	1.13 (29)	8	.88 (22)

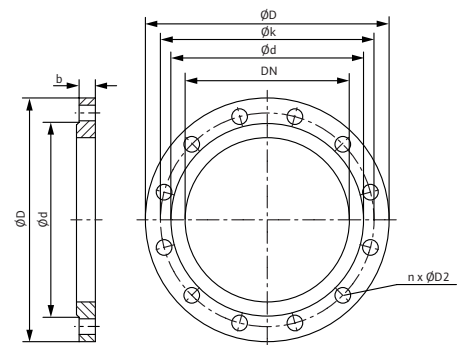

Submittal Data Sheet

Wilco SCP - Horizontal Split Case Pumps



SCP 8 x 8 x 14½ HA

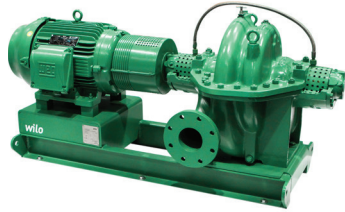

Project:										
Engineer:										
Contractor:										
Submitted By:							Date:			
Approved By:							Date:			

Tag #	Model #	Flow (USGPM)	Head (Feet)	HP	Enclosure TEFC/ODP	Frame	Cycle	Phase	Voltage	RPM
	SCP 8 x 8 x 14½ HA						60 Hz	3		

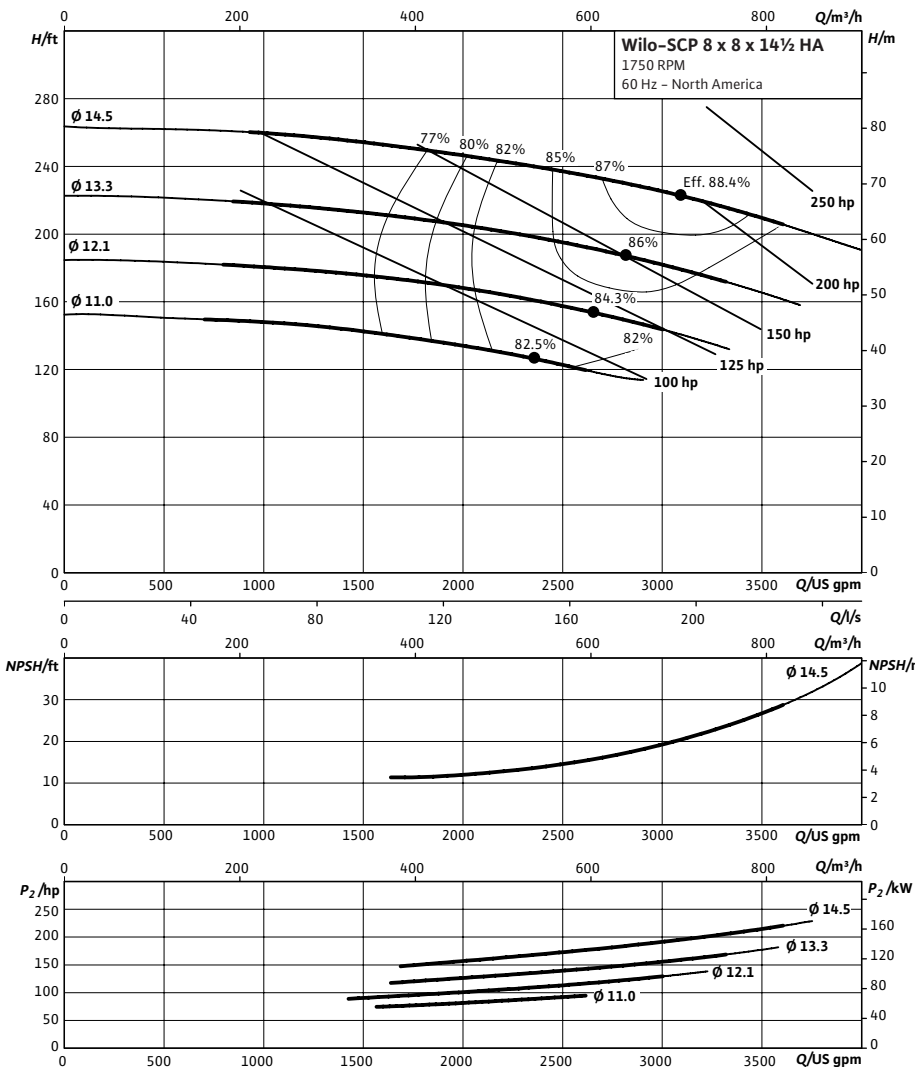

Technical Data

Approved Fluids

- Heating Water
- Cooling and cold water
- Water-Glycol mixtures (for 20-40% glycol and fluid temp ≤ 104°F [40°C])

Fluid Temperature

- Mechanical Seal: 18°F to 250°F (-8°C to 120°C)
- Stuffing Box Packing: 18°F to 220°F (-8°C to 105°C)

Materials of Construction

<input type="checkbox"/> Pump Housing	A48 Class 35
<input type="checkbox"/> Pump Housing (Optional)	Ni-resist BS 3468 Gr 2 / BS 2789 500.1
<input type="checkbox"/> Impeller	BS 84 C83 600
<input type="checkbox"/> Impeller (optional)	A48 Class 35 / BS 84 C83 600
<input type="checkbox"/> Stationary Wear Rings	BS 84 C93 700
<input type="checkbox"/> Pump Shaft	A276 type 410
<input type="checkbox"/> Pump Shaft (optional)	BS 970 316 S16
<input type="checkbox"/> Mechanical Seal	Carbon/silicon carbide/EPDM (E1)
<input type="checkbox"/> Other Mechanical Seals	Avail. on request
<input type="checkbox"/> Additional Spacer Coupling	Avail. on request
<input type="checkbox"/> Other:	

Approval Stamp

Dimensional Drawing

Single Stage Pump

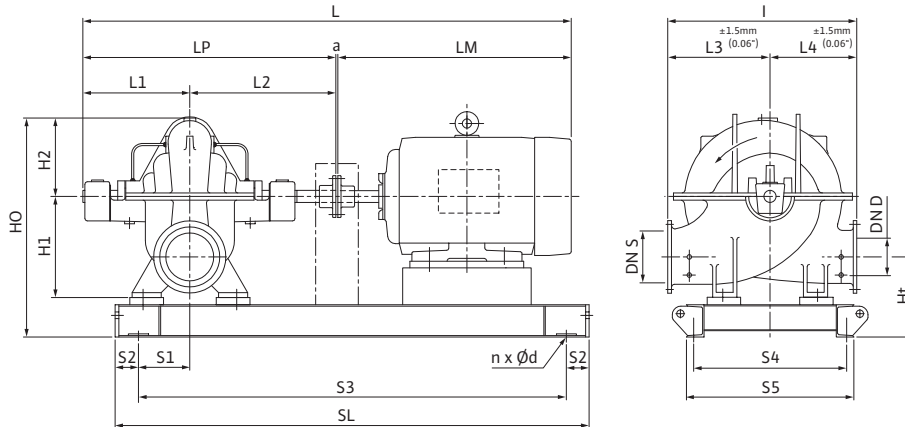

SCP 8 x 8 x 14 1/2 HA

Dimensions - Inches (mm)

Frame	a	L	I	L1	L2	L3	L4	LM	LP	H1	H2	HO	Ht	n	Ød	S1	S2	S3	S4	S5	SL	P5	P6
404T	.50 (13)	78.81 (2002)	30.31 (770)	19.00 (483)	22.06 (560)	16.56 (421)	13.75 (349)	37.25 (946)	41.06 (1043)	16.94 (430)	12.19 (310)	34.94 (887)	12.13 (308)	4	.91 (23)	5.44 (138)	4.00 (102)	54.88 (1394)	18.94 (481)	21.31 (541)	62.88 (1597)	-	-
405T	.50 (13)	85.81 (2180)	30.31 (770)	19.00 (483)	22.06 (560)	16.56 (421)	13.75 (349)	44.25 (1124)	41.06 (1043)	16.94 (430)	12.19 (310)	34.94 (887)	12.13 (308)	4	.91 (23)	5.44 (138)	4.00 (102)	54.88 (1394)	18.94 (481)	21.31 (541)	62.88 (1597)	-	-
444T	.50 (13)	85.81 (2180)	30.31 (770)	19.00 (483)	22.06 (560)	16.56 (421)	13.75 (349)	44.25 (1124)	41.06 (1043)	16.94 (430)	12.19 (310)	34.94 (887)	12.13 (308)	4	.91 (23)	5.44 (138)	4.00 (102)	60.00 (1524)	21.56 (548)	23.88 (607)	68.00 (1727)	-	-
445T / 200 hp	.50 (13)	85.81 (2180)	30.31 (770)	19.00 (483)	22.06 (560)	16.56 (421)	13.75 (349)	44.25 (1124)	41.06 (1043)	16.94 (430)	12.19 (310)	34.94 (887)	12.13 (308)	4	.91 (23)	5.44 (138)	4.00 (102)	60.00 (1524)	21.56 (548)	23.88 (607)	68.00 (1727)	-	-
445T / 250 hp	.19 (5)	89.00 (2261)	30.31 (770)	19.00 (483)	22.06 (560)	16.56 (421)	13.75 (349)	47.75 (1213)	41.06 (1043)	16.94 (430)	12.19 (310)	34.94 (887)	12.13 (308)	4	.91 (23)	5.44 (138)	4.00 (102)	60.69 (1542)	21.56 (548)	23.88 (607)	68.69 (1745)	-	-
445T / 300 hp	.19 (5)	94.69 (2405)	30.31 (770)	19.00 (483)	22.06 (560)	16.56 (421)	13.75 (349)	53.38 (1356)	41.06 (1043)	16.94 (430)	12.19 (310)	34.94 (887)	12.13 (308)	4	.91 (23)	5.44 (138)	4.00 (102)	60.69 (1542)	21.56 (548)	23.88 (607)	68.69 (1745)	-	-

Flange Dimensions - Suction Side

Dimensions - Inches (mm)

DN S #125	ØD	Ød	Øk	b	n	D2
8	13.50 (343)	10.63 (270)	11.75 (298)	1.13 (29)	8	.88 (22)

Flange Dimensions - Discharge Side

Dimensions - Inches (mm)

DN D 125#	ØD	Ød	Øk	b	n	D2
8	13.50 (343)	10.63 (270)	11.75 (298)	1.13 (29)	8	.88 (22)

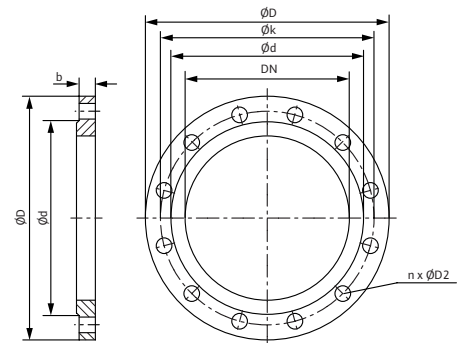

Submittal Data Sheet

Wilo SCP – Horizontal Split Case Pumps



SCP 8 x 8 x 18½ HA

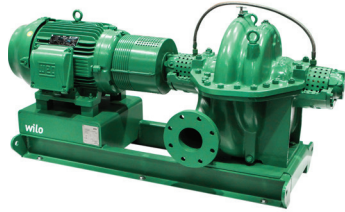

Project:	
Engineer:	
Contractor:	
Submitted By:	Date:
Approved By:	Date:

Tag #	Model #	Flow (USGPM)	Head (Feet)	HP	Enclosure TEFC/ODP	Frame	Cycle	Phase	Voltage	RPM
	SCP 8 x 8 x 18½ HA						60 Hz	3		

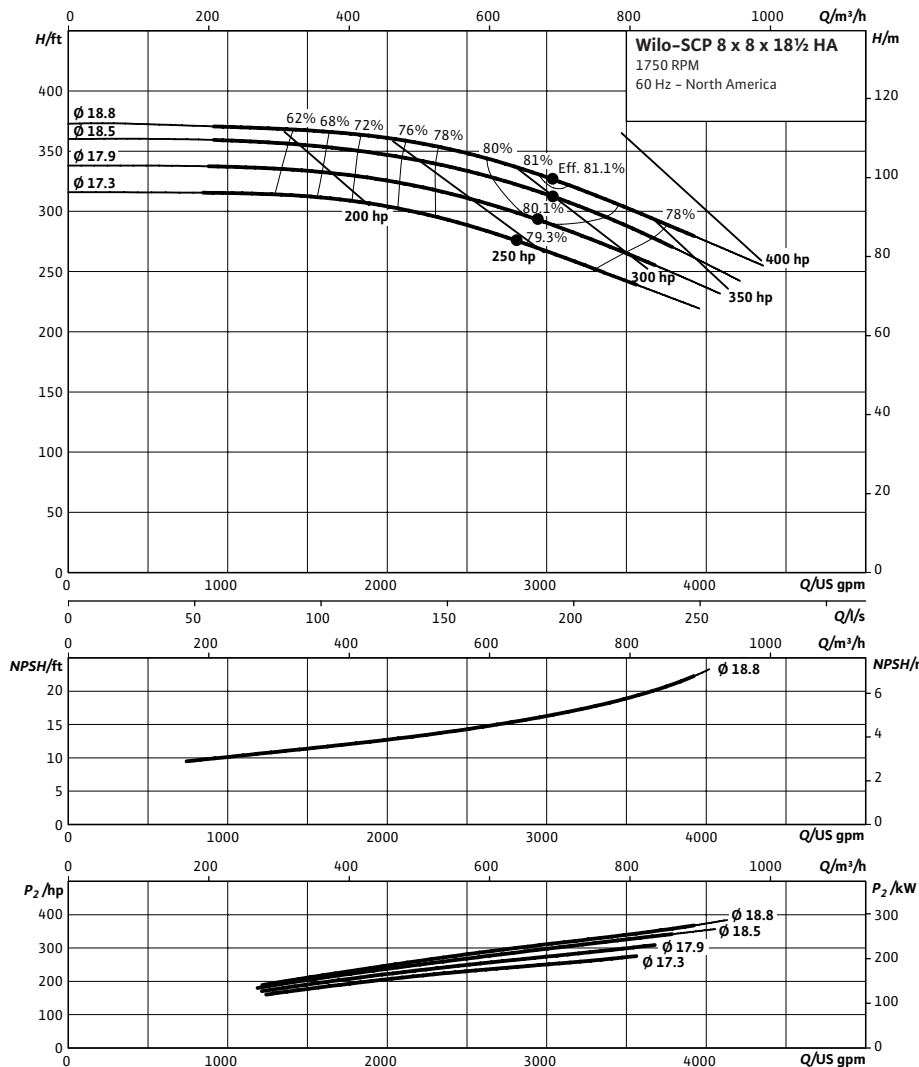

Technical Data

Approved Fluids

Heating Water
Cooling and cold water

Water-Glycol mixtures (for 20-40% glycol and fluid temp ≤ 104°F [40°C])

Fluid Temperature

Mechanical Seal: 18°F to 250°F (-8°C to 120°C)
Stuffing Box Packing: 18°F to 220°F (-8°C to 105°C)

Materials of Construction

<input type="checkbox"/> Pump Housing	A48 Class 35
<input type="checkbox"/> Pump Housing (Optional)	Ni-resist BS 3468 Gr 2 / BS 2789 500.1
<input type="checkbox"/> Impeller	BS 84 C83 600
<input type="checkbox"/> Impeller (optional)	A48 Class 35 / BS 84 C83 600
<input type="checkbox"/> Stationary Wear Rings	BS 84 C93 700
<input type="checkbox"/> Pump Shaft	A276 type 410
<input type="checkbox"/> Pump Shaft (optional)	BS 970 316 S16
<input type="checkbox"/> Mechanical Seal	Carbon/silicon carbide/EPDM (E1)
<input type="checkbox"/> Other Mechanical Seals	Avail. on request
<input type="checkbox"/> Additional Spacer Coupling	Avail. on request
<input type="checkbox"/> Other:	

Approval Stamp

Dimensional Drawing

Single Stage Pump

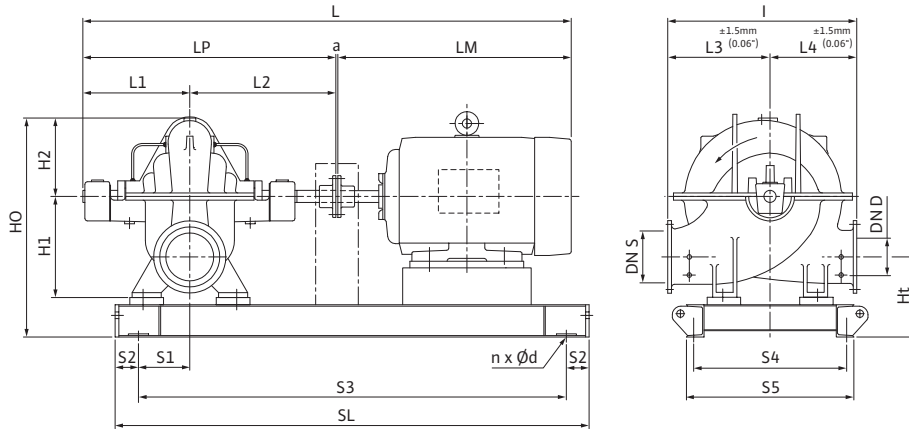

SCP 8 x 8 x 18½ HA

Dimensions - Inches (mm)

Frame	a	L	I	L1	L2	L3	L4	LM	LP	H1	H2	HO	Ht	n	Ød	S1	S2	S3	S4	S5	SL	P5	P6
445T / 200 hp	.50 (13)	89.50 (2273)	36.50 (927)	20.69 (526)	24.13 (613)	18.50 (470)	18.00 (457)	44.25 (1124)	44.75 (1137)	18.25 (464)	14.56 (370)	38.63 (981)	10.56 (268)	4	.91 (23)	6.25 (159)	4.00 (102)	62.81 (1595)	21.56 (548)	23.88 (607)	70.81 (1799)	-	-
445T / 250 hp	.19 (5)	92.69 (2354)	36.50 (927)	20.69 (526)	24.13 (613)	18.50 (470)	18.00 (457)	47.75 (1213)	44.75 (1137)	18.25 (464)	14.56 (370)	38.63 (981)	10.56 (268)	4	.91 (23)	6.25 (159)	4.00 (102)	63.56 (1614)	21.56 (548)	23.88 (607)	71.56 (1818)	-	-
445T / 300 hp	.19 (5)	98.38 (2499)	36.50 (927)	20.69 (526)	24.13 (613)	18.50 (470)	18.00 (457)	53.38 (1356)	44.75 (1137)	18.25 (464)	14.56 (370)	38.63 (981)	10.56 (268)	4	.91 (23)	6.25 (159)	4.00 (102)	63.56 (1614)	21.56 (548)	23.88 (607)	71.56 (1818)	-	-
449T / 350 hp	.19 (5)	98.38 (2499)	36.50 (927)	20.69 (526)	24.13 (613)	18.50 (470)	18.00 (457)	53.38 (1356)	44.75 (1137)	18.25 (464)	14.56 (370)	38.63 (981)	10.56 (268)	4	.91 (23)	6.25 (159)	4.00 (102)	71.81 (1824)	21.06 (535)	23.88 (607)	79.81 (2027)	-	-
449T / 400 hp	.19 (5)	98.38 (2499)	36.50 (927)	20.69 (526)	24.13 (613)	18.50 (470)	18.00 (457)	53.38 (1356)	44.75 (1137)	18.25 (464)	14.56 (370)	38.63 (981)	10.56 (268)	4	.91 (23)	6.25 (159)	4.00 (102)	71.81 (1824)	21.06 (535)	23.88 (607)	79.81 (2027)	-	-

Flange Dimensions – Suction Side

Dimensions - Inches (mm)

DN S #125	ØD	Ød	Øk	b	n	D2
8	13.50 (343)	10.63 (270)	11.75 (298)	1.13 (29)	8	.88 (22)

Flange Dimensions – Discharge Side

Dimensions - Inches (mm)

DN D 125#	ØD	Ød	Øk	b	n	D2
8	13.50 (343)	10.63 (270)	11.75 (298)	1.13 (29)	8	.88 (22)

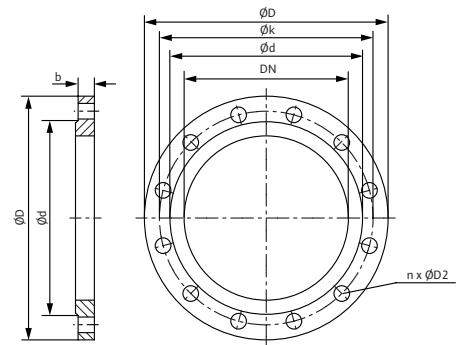

Submittal Data Sheet

Wilco SCP - Horizontal Split Case Pumps



SCP 8 x 8 x 21½ HA

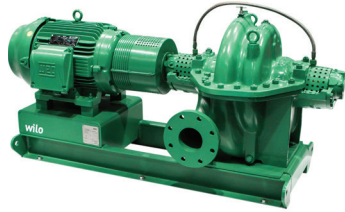

Project:	
Engineer:	
Contractor:	
Submitted By:	Date:
Approved By:	Date:

Tag #	Model #	Flow (USGPM)	Head (Feet)	HP	Enclosure TEFC/ODP	Frame	Cycle	Phase	Voltage	RPM
	SCP 8 x 8 x 21½ HA						60 Hz	3		

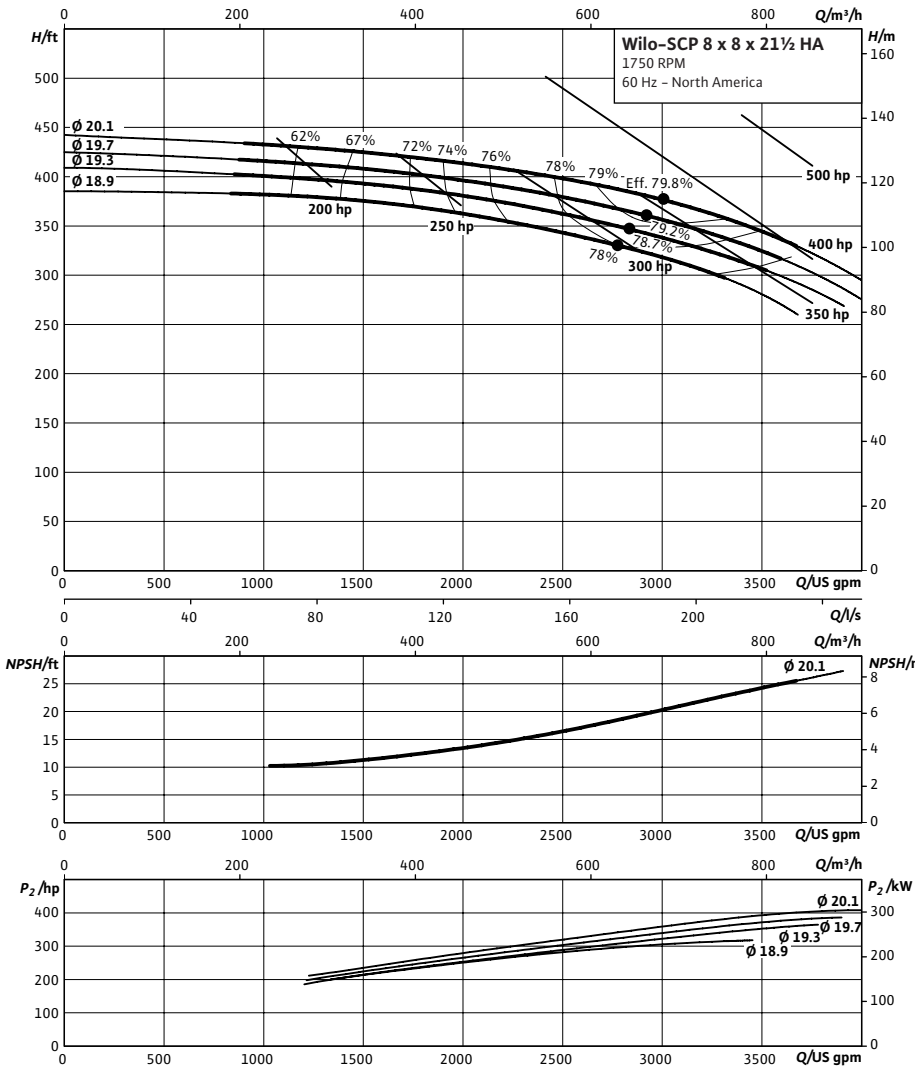

Technical Data

Approved Fluids	
Heating Water	
Cooling and cold water	
Water-Glycol mixtures (for 20-40% glycol and fluid temp ≤ 104°F [40°C])	
Fluid Temperature	
Mechanical Seal	18°F to 250°F (-8°C to 120°C)
Stuffing Box Packing	18°F to 220°F (-8°C to 105°C)

Materials of Construction

<input type="checkbox"/> Pump Housing	A48 Class 35
<input type="checkbox"/> Pump Housing (Optional)	Ni-resist BS 3468 Gr 2 / BS 2789 500.1
<input type="checkbox"/> Impeller	BS 84 C83 600
<input type="checkbox"/> Impeller (optional)	A48 Class 35 / BS 84 C83 600
<input type="checkbox"/> Stationary Wear Rings	BS 84 C93 700
<input type="checkbox"/> Pump Shaft	A276 type 410
<input type="checkbox"/> Pump Shaft (optional)	BS 970 316 S16
<input type="checkbox"/> Mechanical Seal	Carbon/silicon carbide/EPDM (E1)
<input type="checkbox"/> Other Mechanical Seals	Avail. on request
<input type="checkbox"/> Additional Spacer Coupling	Avail. on request
<input type="checkbox"/> Other:	

Approval Stamp

Dimensional Drawing

Single Stage Pump

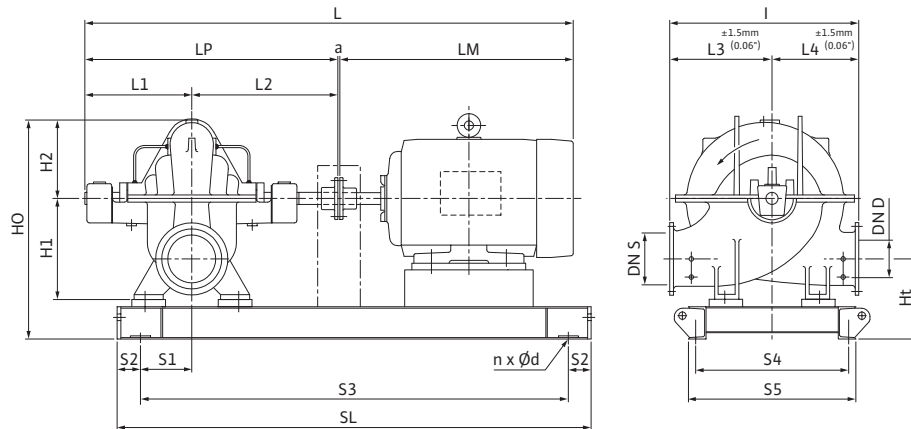

SCP 8 x 8 x 21½ HA

Dimensions - Inches (mm)

Frame	a	L	I	L1	L2	L3	L4	LM	LP	H1	H2	HO	Ht	n	Ød	S1	S2	S3	S4	S5	SL	P5	P6
445T / 200 hp	.50 (13)	89.50 (2273)	36.50 (927)	20.69 (526)	24.13 (613)	18.50 (470)	18.00 (457)	44.25 (1124)	44.75 (1137)	18.25 (464)	14.56 (370)	38.63 (981)	10.56 (268)	4	.91 (23)	6.25 (159)	4.00 (102)	62.81 (1595)	21.56 (548)	23.88 (607)	70.81 (1799)	-	-
445T / 250 hp	.19 (5)	92.69 (2354)	36.50 (927)	20.69 (526)	24.13 (613)	18.50 (470)	18.00 (457)	47.75 (1213)	44.75 (1137)	18.25 (464)	14.56 (370)	38.63 (981)	10.56 (268)	4	.91 (23)	6.25 (159)	4.00 (102)	63.56 (1614)	21.56 (548)	23.88 (607)	71.56 (1818)	-	-
445T / 300 hp	.19 (5)	98.38 (2499)	36.50 (927)	20.69 (526)	24.13 (613)	18.50 (470)	18.00 (457)	53.38 (1356)	44.75 (1137)	18.25 (464)	14.56 (370)	38.63 (981)	10.56 (268)	4	.91 (23)	6.25 (159)	4.00 (102)	63.56 (1614)	21.56 (548)	23.88 (607)	71.56 (1818)	-	-
449T / 350 hp	.19 (5)	98.38 (2499)	36.50 (927)	20.69 (526)	24.13 (613)	18.50 (470)	18.00 (457)	53.38 (1356)	44.75 (1137)	18.25 (464)	14.56 (370)	38.63 (981)	10.56 (268)	4	.91 (23)	6.25 (159)	4.00 (102)	71.81 (1824)	21.06 (535)	23.88 (607)	79.81 (2027)	-	-
449T / 400 hp	.19 (5)	98.38 (2499)	36.50 (927)	20.69 (526)	24.13 (613)	18.50 (470)	18.00 (457)	53.38 (1356)	44.75 (1137)	18.25 (464)	14.56 (370)	38.63 (981)	10.56 (268)	4	.91 (23)	6.25 (159)	4.00 (102)	71.81 (1824)	21.06 (535)	23.88 (607)	79.81 (2027)	-	-

Flange Dimensions – Suction Side

Dimensions - Inches (mm)

DN S #125	ØD	Ød	Øk	b	n	D2
8	13.50 (343)	10.63 (270)	11.75 (298)	1.13 (29)	8	.88 (22)

Flange Dimensions – Discharge Side

Dimensions - Inches (mm)

DN D 125#	ØD	Ød	Øk	b	n	D2
8	13.50 (343)	10.63 (270)	11.75 (298)	1.13 (29)	8	.88 (22)

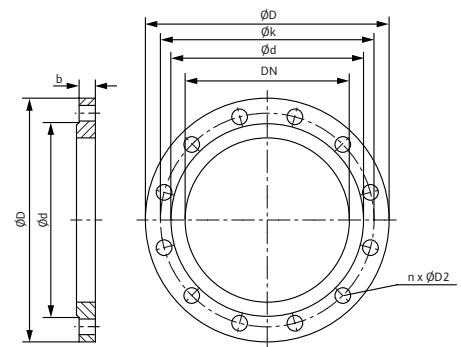

Submittal Data Sheet

Wilo SCP – Horizontal Split Case Pumps



SCP 10 x 8 x 12½ HA

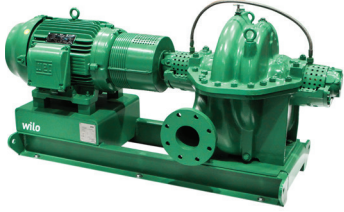

Project:										
Engineer:										
Contractor:										
Submitted By:							Date:			
Approved By:							Date:			

Tag #	Model #	Flow (USGPM)	Head (Feet)	HP	Enclosure TEFC/ODP	Frame	Cycle	Phase	Voltage	RPM
	SCP 10 x 8 x 12½ HA						60 Hz	3		

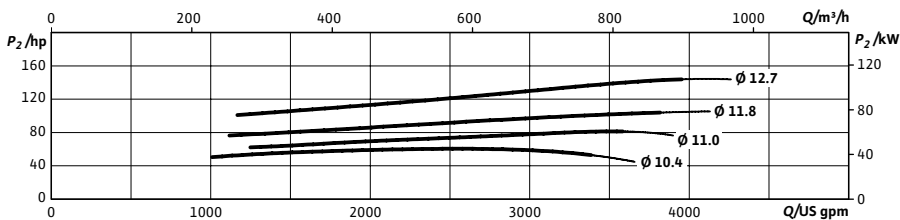
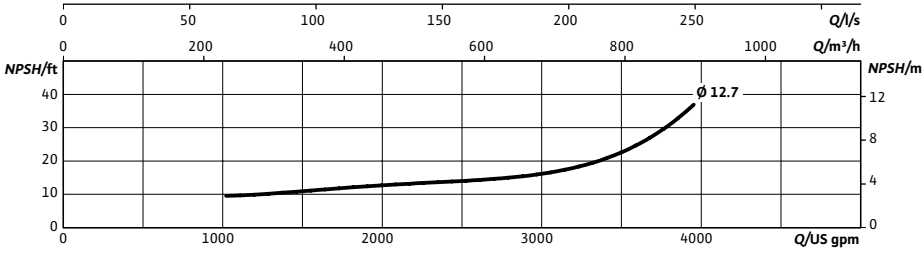
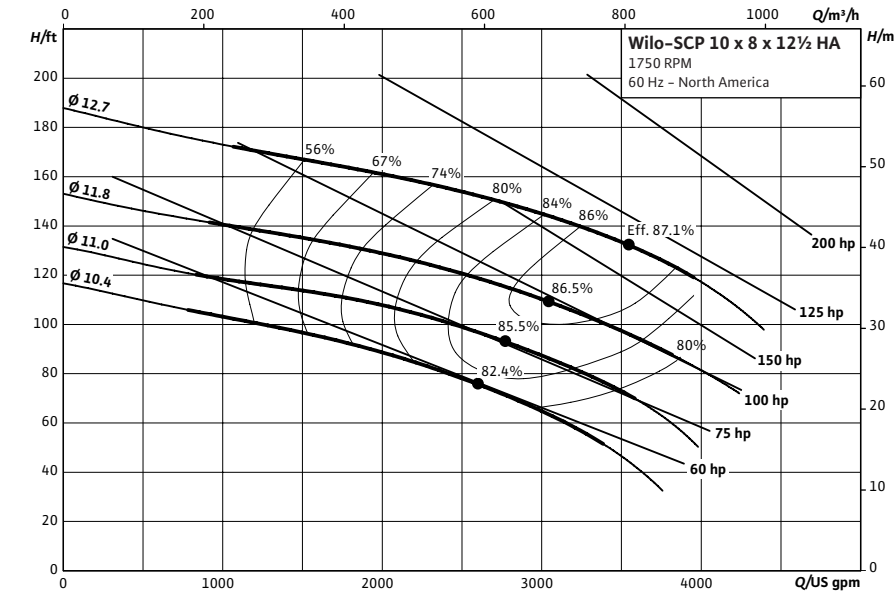

Technical Data

Approved Fluids

Heating Water
Cooling and cold water

Water-Glycol mixtures (for 20–40% glycol and fluid temp ≤ 104°F [40°C])

Fluid Temperature

Mechanical Seal: 18°F to 250°F (–8°C to 120°C)
Stuffing Box Packing: 18°F to 220°F (–8°C to 105°C)

Materials of Construction

<input type="checkbox"/> Pump Housing	A48 Class 35
<input type="checkbox"/> Pump Housing (Optional)	Ni-resist BS 3468 Gr 2 / BS 2789 500.1
<input type="checkbox"/> Impeller	BS 84 C83 600
<input type="checkbox"/> Impeller (optional)	A48 Class 35 / BS 84 C83 600
<input type="checkbox"/> Stationary Wear Rings	BS 84 C93 700
<input type="checkbox"/> Pump Shaft	A276 type 410
<input type="checkbox"/> Pump Shaft (optional)	BS 970 316 S16
<input type="checkbox"/> Mechanical Seal	Carbon/silicon carbide/EPDM (E1)
<input type="checkbox"/> Other Mechanical Seals	Avail. on request
<input type="checkbox"/> Additional Spacer Coupling	Avail. on request
<input type="checkbox"/> Other:	

Approval Stamp

Dimensional Drawing

Single Stage Pump

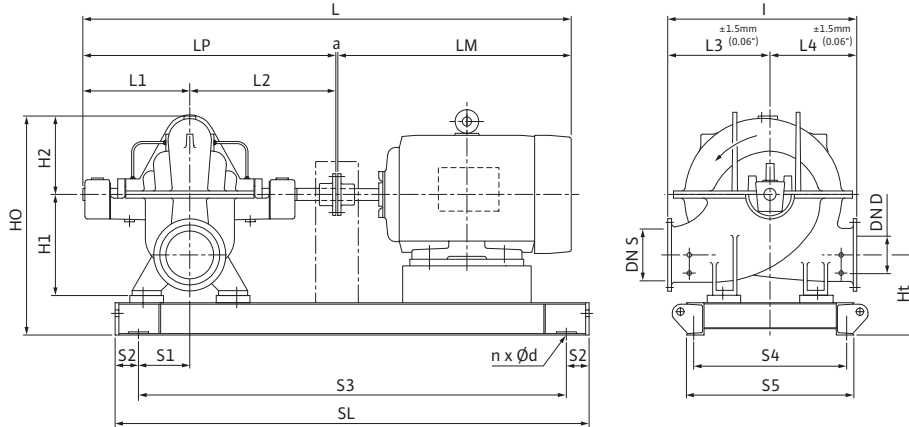

SCP 10 x 8 x 1 1/2 HA

Dimensions - Inches (mm)

Frame	a	L	I	L1	L2	L3	L4	LM	LP	H1	H2	HO	Ht	n	Ød	S1	S2	S3	S4	S5	SL	P5	P6
364T	.50 (13)	68.38 (1737)	29.50 (749)	16.19 (411)	18.69 (475)	17.00 (432)	12.50 (318)	33.00 (838)	34.81 (884)	16.75 (425)	11.44 (291)	33.94 (862)	12.75 (324)	4	.91 (23)	6.25 (159)	4.00 (102)	48.31 (1227)	17.38 (441)	19.75 (502)	56.31 (1430)	-	-
365T	.50 (13)	68.38 (1737)	29.50 (749)	16.19 (411)	18.69 (475)	17.00 (432)	12.50 (318)	33.00 (838)	34.81 (884)	16.75 (425)	11.44 (291)	33.94 (862)	12.75 (324)	4	.91 (23)	6.25 (159)	4.00 (102)	48.31 (1227)	17.38 (441)	19.75 (502)	56.31 (1430)	-	-
404T	.50 (13)	72.56 (1843)	29.50 (749)	16.19 (411)	18.69 (475)	17.00 (432)	12.50 (318)	37.25 (946)	34.81 (884)	16.75 (425)	11.44 (291)	33.94 (862)	12.75 (324)	4	.91 (23)	6.25 (159)	4.00 (102)	52.25 (1327)	18.50 (470)	20.88 (530)	60.25 (1530)	-	-
405T	.50 (13)	79.56 (2021)	29.50 (749)	16.19 (411)	18.69 (475)	17.00 (432)	12.50 (318)	44.25 (1124)	34.81 (884)	16.75 (425)	11.44 (291)	33.94 (862)	12.75 (324)	4	.91 (23)	6.25 (159)	4.00 (102)	52.25 (1327)	18.50 (470)	20.88 (530)	60.25 (1530)	-	-
444T	.50 (13)	79.56 (2021)	29.50 (749)	16.19 (411)	18.69 (475)	17.00 (432)	12.50 (318)	44.25 (1124)	34.81 (884)	16.75 (425)	11.44 (291)	33.94 (862)	12.75 (324)	4	.91 (23)	6.25 (159)	4.00 (102)	57.38 (1457)	21.56 (548)	23.88 (607)	56.38 (1661)	-	-
445T	.50 (13)	79.56 (2021)	29.50 (749)	16.19 (411)	18.69 (475)	17.00 (432)	12.50 (318)	44.25 (1124)	34.81 (884)	16.75 (425)	11.44 (291)	33.94 (862)	12.75 (324)	4	.91 (23)	6.25 (159)	4.00 (102)	57.38 (1457)	21.56 (548)	23.88 (607)	56.38 (1661)	-	-

Flange Dimensions – Suction Side

Dimensions - Inches (mm)

DN S #125	ØD	Ød	Øk	b	n	D2
10	16.00 (406)	12.75 (324)	14.25 (362)	1.19 (30)	12	1.00 (25)

Flange Dimensions – Discharge Side

Dimensions - Inches (mm)

DN D 125#	ØD	Ød	Øk	b	n	D2
8	13.50 (343)	10.63 (270)	11.75 (298)	1.13 (29)	8	.88 (22)

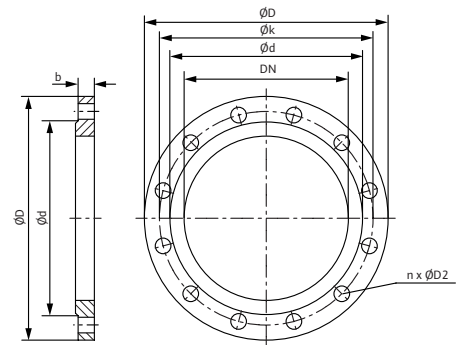

Submittal Data Sheet

Wilo SCP – Horizontal Split Case Pumps



SCP 10 x 8 x 15 HA

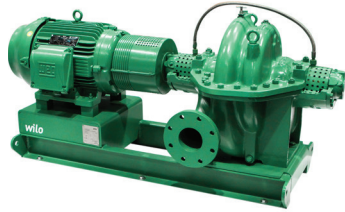

Project:	
Engineer:	
Contractor:	
Submitted By:	Date:
Approved By:	Date:

Tag #	Model #	Flow (USGPM)	Head (Feet)	HP	Enclosure TEFC/ODP	Frame	Cycle	Phase	Voltage	RPM
	SCP 10 x 8 x 15 HA						60 Hz	3		

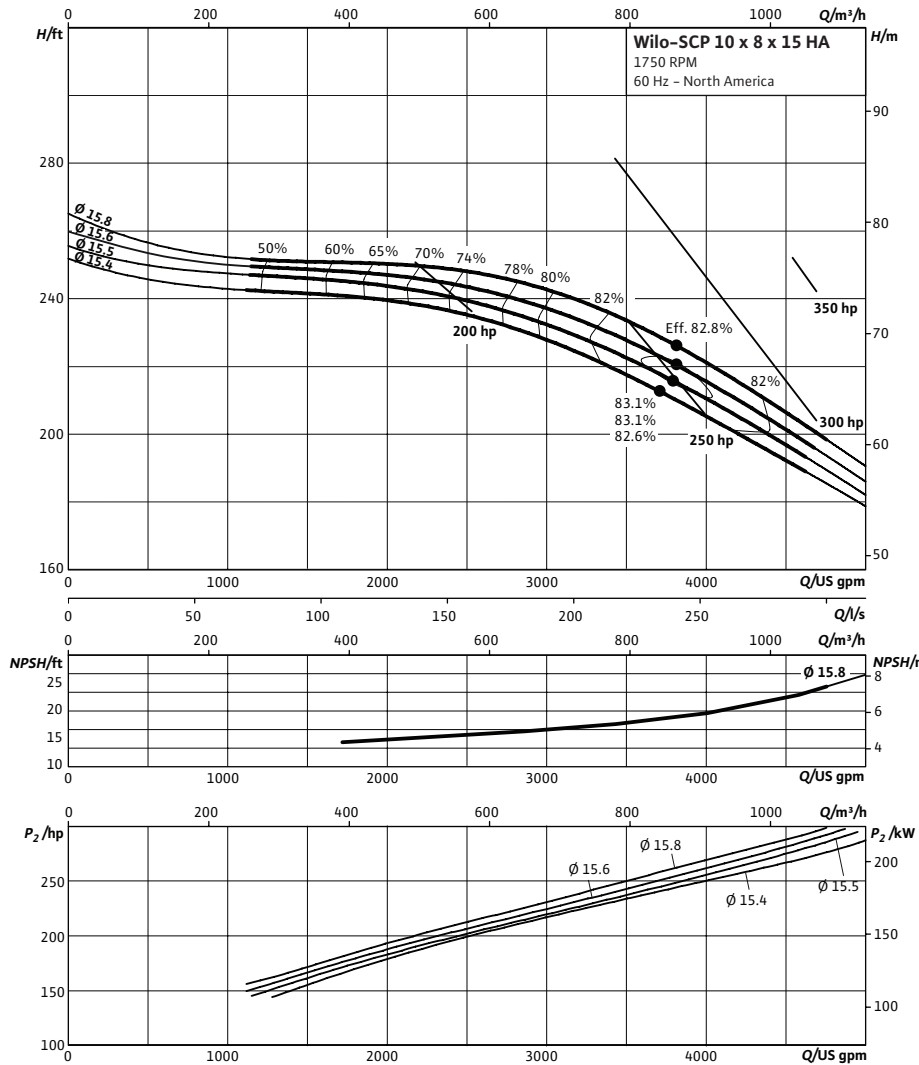

Technical Data

Approved Fluids

Heating Water
Cooling and cold water

Water-Glycol mixtures (for 20-40% glycol and fluid temp $\leq 104^\circ\text{F}$ [40°C])

Fluid Temperature

Mechanical Seal: 18°F to 250°F (-8°C to 120°C)
Stuffing Box Packing: 18°F to 220°F (-8°C to 105°C)

Materials of Construction

<input type="checkbox"/>	Pump Housing	A48 Class 35
<input type="checkbox"/>	Pump Housing (Optional)	Ni-resist BS 3468 Gr 2 / BS 2789 500.1
<input type="checkbox"/>	Impeller	BS 84 C83 600
<input type="checkbox"/>	Impeller (optional)	A48 Class 35 / BS 84 C83 600
<input type="checkbox"/>	Stationary Wear Rings	BS 84 C93 700
<input type="checkbox"/>	Pump Shaft	A276 type 410
<input type="checkbox"/>	Pump Shaft (optional)	BS 970 316 S16
<input type="checkbox"/>	Mechanical Seal	Carbon/silicon carbide/EPDM (E1)
<input type="checkbox"/>	Other Mechanical Seals	Avail. on request
<input type="checkbox"/>	Additional Spacer Coupling	Avail. on request
<input type="checkbox"/>	Other:	

Approval Stamp

Dimensional Drawing

Single Stage Pump

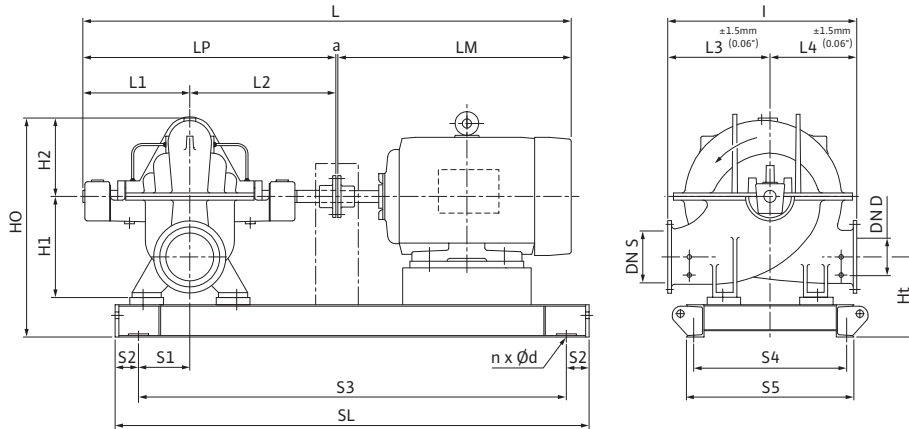

SCP 10 x 8 x 15 HA

Dimensions - Inches (mm)

Frame	a	L	l	L1	L2	L3	L4	LM	LP	H1	H2	HO	Ht	n	Ød	S1	S2	S3	S4	S5	SL	P5	P6
445T / 200 hp	.50 (13)	89.50 (2273)	37.00 (940)	20.69 (526)	24.13 (613)	19.00 (483)	18.00 (457)	44.25 (1124)	44.75 (1137)	18.25 (464)	13.75 (349)	37.88 (962)	12.56 (319)	4	.91 (23)	6.25 (159)	4.00 (102)	62.81 (1595)	21.56 (548)	23.38 (607)	70.81 (1799)	-	-
445T / 250 hp	.19 (5)	92.69 (2354)	37.00 (940)	20.69 (526)	24.13 (613)	19.00 (483)	18.00 (457)	44.25 (1124)	44.75 (1137)	18.25 (464)	13.75 (349)	37.88 (962)	12.56 (319)	4	.91 (23)	6.25 (159)	4.00 (102)	63.56 (1614)	21.56 (548)	23.38 (607)	71.56 (1818)	-	-
445T / 300 hp	.19 (5)	98.38 (2499)	37.00 (940)	20.69 (526)	24.13 (613)	19.00 (483)	18.00 (457)	44.25 (1124)	44.75 (1137)	18.25 (464)	13.75 (349)	37.88 (962)	12.56 (319)	4	.91 (23)	6.25 (159)	4.00 (102)	63.56 (1614)	21.56 (548)	23.38 (607)	71.56 (1818)	-	-
449T	.19 (5)	98.38 (2499)	37.00 (940)	20.69 (526)	24.13 (613)	19.00 (483)	18.00 (457)	44.25 (1124)	44.75 (1137)	18.25 (464)	13.75 (349)	37.88 (962)	12.56 (319)	4	.91 (23)	6.25 (159)	4.00 (102)	71.81 (1824)	21.06 (535)	23.38 (594)	79.81 (2027)	-	-

Flange Dimensions – Suction Side

Dimensions - Inches (mm)

DN S #125	ØD	Ød	Øk	b	n	D2
10	16.00 (406)	12.75 (324)	14.25 (362)	1.19 (30)	12	1.00 (25)

Flange Dimensions – Discharge Side

Dimensions - Inches (mm)

DN D 125#	ØD	Ød	Øk	b	n	D2
8	13.50 (343)	10.63 (270)	11.75 (298)	1.13 (29)	8	.88 (22)

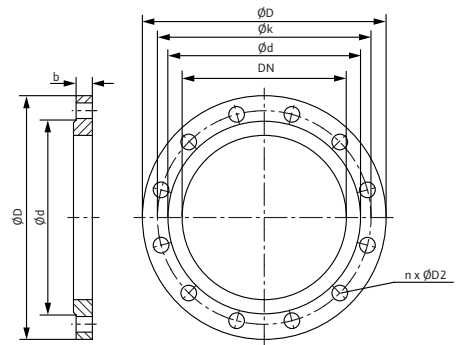

Submittal Data Sheet

Wilo SCP – Horizontal Split Case Pumps



SCP 10 x 8 x 17 HA

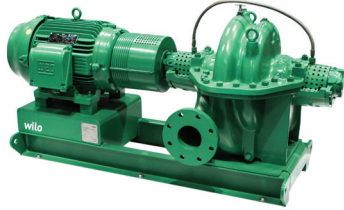

Project:	
Engineer:	
Contractor:	
Submitted By:	Date:
Approved By:	Date:

Tag #	Model #	Flow (USGPM)	Head (Feet)	HP	Enclosure TEFC/ODP	Frame	Cycle	Phase	Voltage	RPM
	SCP 10 x 8 x 17 HA						60 Hz	3		

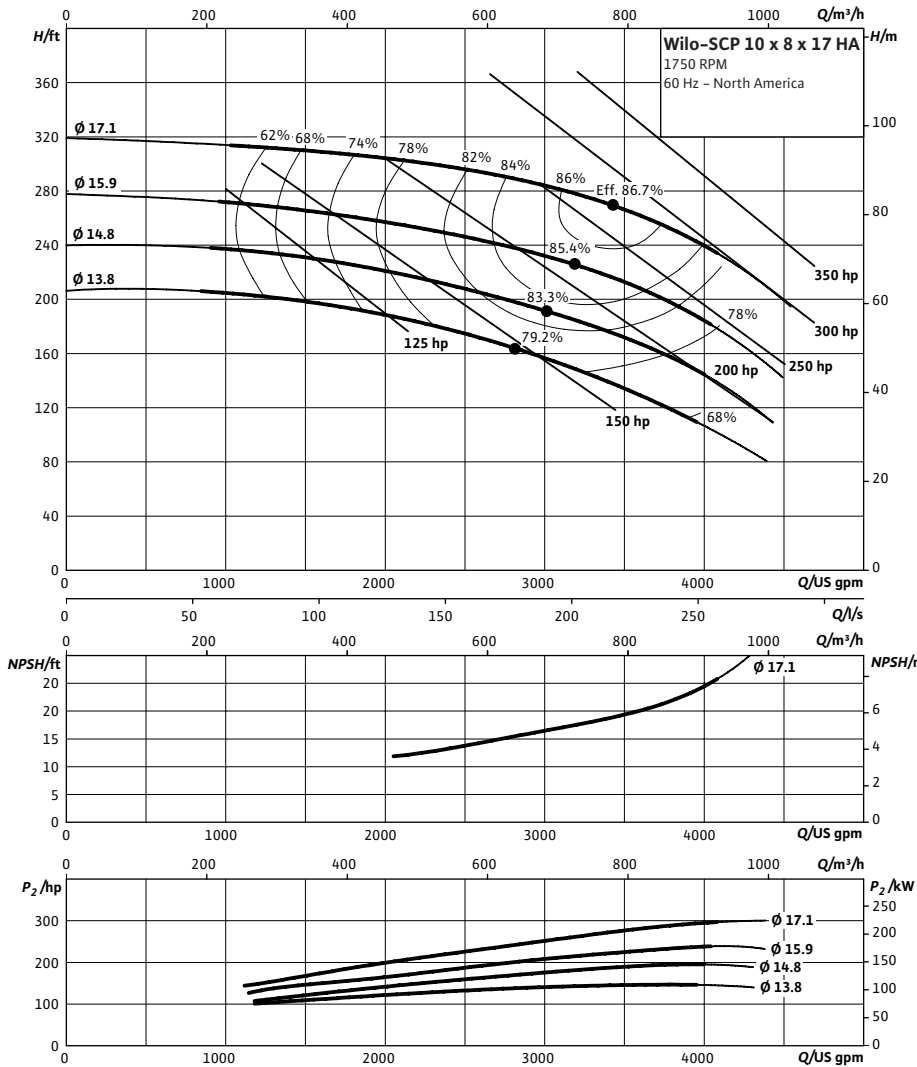

Technical Data

Approved Fluids

Heating Water
Cooling and cold water

Water-Glycol mixtures (for 20–40% glycol and fluid temp ≤ 104°F [40°C])

Fluid Temperature

Mechanical Seal 18°F to 250°F (–8°C to 120°C)
Stuffing Box Packing 18°F to 220°F (–8°C to 105°C)

Materials of Construction

<input type="checkbox"/> Pump Housing	A48 Class 35
<input type="checkbox"/> Pump Housing (Optional)	Ni-resist BS 3468 Gr 2 / BS 2789 500.1
<input type="checkbox"/> Impeller	BS 84 C83 600
<input type="checkbox"/> Impeller (optional)	A48 Class 35 / BS 84 C83 600
<input type="checkbox"/> Stationary Wear Rings	BS 84 C93 700
<input type="checkbox"/> Pump Shaft	A276 type 410
<input type="checkbox"/> Pump Shaft (optional)	BS 970 316 S16
<input type="checkbox"/> Mechanical Seal	Carbon/silicon carbide/EPDM (E1)
<input type="checkbox"/> Other Mechanical Seals	Avail. on request
<input type="checkbox"/> Additional Spacer Coupling	Avail. on request
<input type="checkbox"/> Other:	

Approval Stamp

Dimensional Drawing

Single Stage Pump

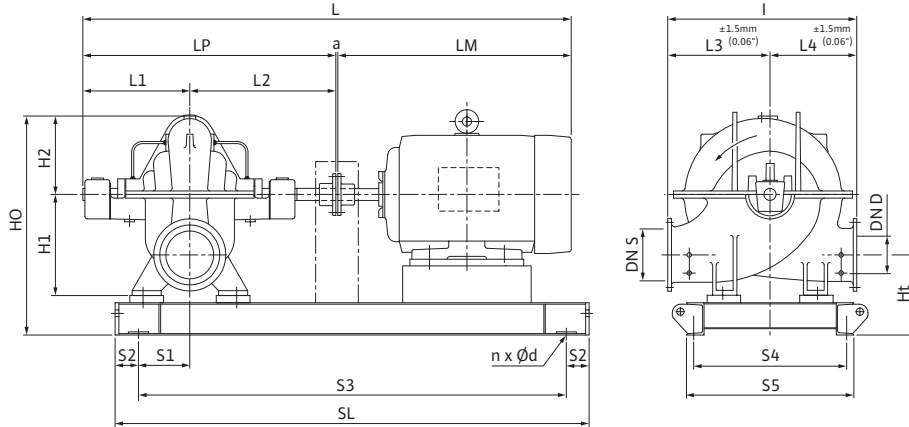

SCP 10 x 8 x 17 HA

Dimensions - Inches (mm)

Frame	a	L	l	L1	L2	L3	L4	LM	LP	H1	H2	HO	Ht	n	Ød	S1	S2	S3	S4	S5	SL	P5	P6
405T	.50 (13)	89.13 (2264)	33.06 (840)	19.88 (505)	24.50 (622)	17.31 (440)	15.75 (400)	44.25 (1124)	44.38 (1127)	18.31 (465)	13.00 (330)	37.25 (946)	12.44 (316)	4	.91 (23)	6.44 (164)	4.00 (102)	58.31 (1481)	21.69 (551)	24.06 (611)	66.31 (1684)	-	-
444T	.50 (13)	89.13 (2264)	33.06 (840)	19.88 (505)	24.50 (622)	17.31 (440)	15.75 (400)	44.25 (1124)	44.38 (1127)	18.31 (465)	13.00 (330)	37.25 (946)	12.44 (316)	4	.91 (23)	6.44 (164)	4.00 (102)	63.44 (1611)	21.69 (551)	24.06 (611)	71.44 (1815)	-	-
445T/ 200 hp	.50 (13)	89.13 (2264)	33.06 (840)	19.88 (505)	24.50 (622)	17.31 (440)	15.75 (400)	44.25 (1124)	44.38 (1127)	18.31 (465)	13.00 (330)	37.25 (946)	12.44 (316)	4	.91 (23)	6.25 (159)	4.00 (102)	63.44 (1611)	21.69 (551)	24.06 (611)	71.44 (1815)	-	-
445T/ 250 hp	.19 (5)	92.31 (2340)	33.06 (840)	19.88 (505)	24.50 (622)	17.31 (440)	15.75 (400)	47.75 (1213)	44.38 (1127)	18.31 (465)	13.00 (330)	37.25 (946)	12.44 (316)	4	.91 (23)	6.25 (159)	4.00 (102)	64.13 (1629)	21.69 (551)	24.06 (611)	72.13 (1832)	-	-
445T/ 300 hp	.19 (5)	98.00 (2489)	33.06 (840)	19.88 (505)	24.50 (622)	17.31 (440)	15.75 (400)	53.38 (1356)	44.38 (1127)	18.31 (465)	13.00 (330)	37.25 (946)	12.44 (316)	4	.91 (23)	6.25 (159)	4.00 (102)	64.13 (1629)	21.69 (551)	24.06 (611)	72.13 (1832)	-	-
449T	.19 (5)	98.00 (2489)	33.06 (840)	19.88 (505)	24.50 (622)	17.31 (440)	15.75 (400)	53.38 (1356)	44.38 (1127)	18.31 (465)	13.00 (330)	37.25 (946)	12.44 (316)	4	.91 (23)	6.25 (159)	4.00 (102)	72.38 (1838)	21.69 (551)	24.06 (611)	80.38 (2052)	-	-

Flange Dimensions – Suction Side

Dimensions - Inches (mm)

DN S #125	ØD	Ød	Øk	b	n	D2
10	16.00 (406)	12.75 (324)	14.25 (362)	1.19 (30)	12	1.00 (25)

Flange Dimensions – Discharge Side

Dimensions - Inches (mm)

DND 125#	ØD	Ød	Øk	b	n	D2
8	13.50 (343)	10.63 (270)	11.75 (298)	1.13 (29)	8	.88 (22)

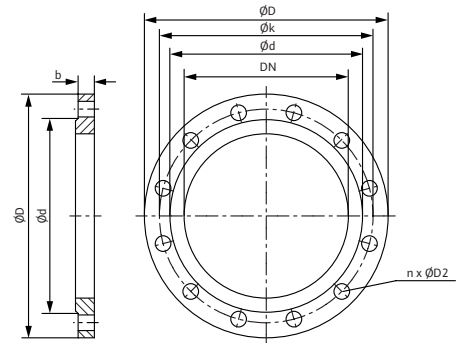

Submittal Data Sheet

Wilco SCP - Horizontal Split Case Pumps



SCP 10 x 8 x 18 HA

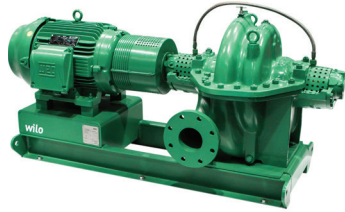

Project:	
Engineer:	
Contractor:	
Submitted By:	Date:
Approved By:	Date:

Tag #	Model #	Flow (USGPM)	Head (Feet)	HP	Enclosure TEFC/ODP	Frame	Cycle	Phase	Voltage	RPM
	SCP 10 x 8 x 18 HA						60 Hz	3		

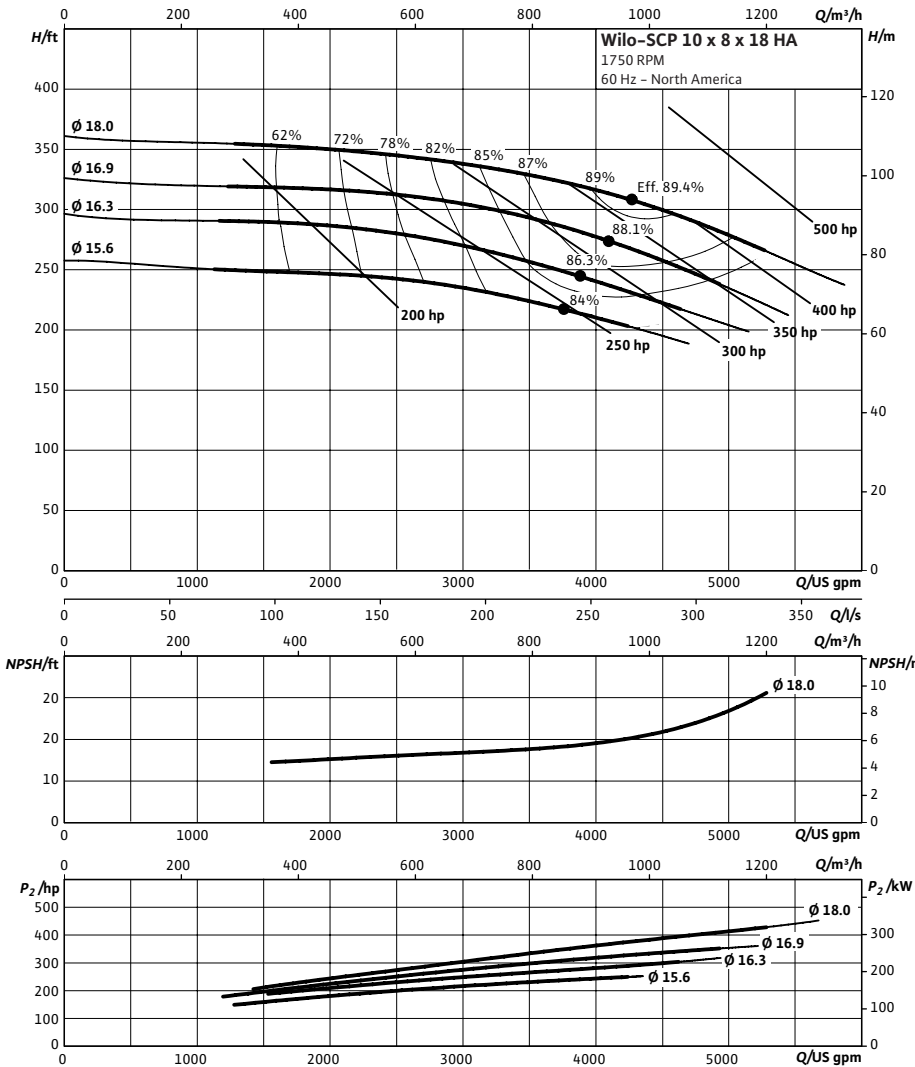

Technical Data

Approved Fluids

Heating Water
Cooling and cold water

Water-Glycol mixtures (for 20-40% glycol and fluid temp ≤ 104°F [40°C])

Fluid Temperature

Mechanical Seal 18°F to 250°F (-8°C to 120°C)
Stuffing Box Packing 18°F to 220°F (-8°C to 105°C)

Materials of Construction

<input type="checkbox"/>	Pump Housing	A48 Class 35
<input type="checkbox"/>	Pump Housing (Optional)	Ni-resist BS 3468 Gr 2 / BS 2789 500.1
<input type="checkbox"/>	Impeller	BS 84 C83 600
<input type="checkbox"/>	Impeller (optional)	A48 Class 35 / BS 84 C83 600
<input type="checkbox"/>	Stationary Wear Rings	BS 84 C93 700
<input type="checkbox"/>	Pump Shaft	A276 type 410
<input type="checkbox"/>	Pump Shaft (optional)	BS 970 316 S16
<input type="checkbox"/>	Mechanical Seal	Carbon/silicon carbide/EPDM (E1)
<input type="checkbox"/>	Other Mechanical Seals	Avail. on request
<input type="checkbox"/>	Additional Spacer Coupling	Avail. on request
<input type="checkbox"/>	Other:	

Approval Stamp

Dimensional Drawing

Single Stage Pump

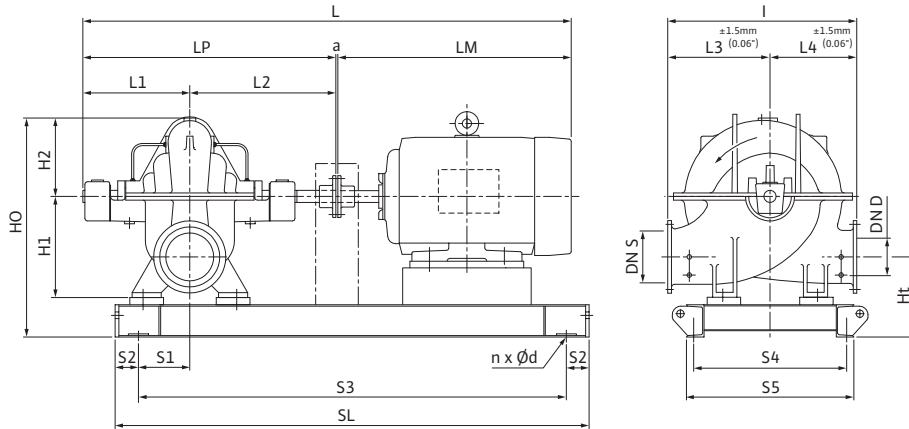

SCP 10 x 8 x 18 HA

Dimensions - Inches (mm)

Frame	a	L	I	L1	L2	L3	L4	LM	LP	H1	H2	HO	Ht	n	Ød	S1	S2	S3	S4	S5	SL	P5	P6
445T / 200 hp	.50 (13)	89.50 (2273)	37.00 (940)	20.69 (526)	24.13 (613)	19.00 (483)	18.00 (457)	44.25 (1124)	44.75 (1137)	18.25 (464)	13.75 (349)	37.88 (962)	12.31 (313)	4	.91 (23)	6.25 (159)	4.00 (102)	62.81 (1595)	21.56 (548)	23.88 (607)	70.81 (1799)	-	-
445T / 250 hp	.19 (5)	92.69 (2354)	37.00 (940)	20.69 (526)	24.13 (613)	19.00 (483)	18.00 (457)	47.75 (1213)	44.75 (1137)	18.25 (464)	13.75 (349)	37.88 (962)	12.31 (313)	4	.91 (23)	6.25 (159)	4.00 (102)	63.56 (1614)	21.56 (548)	23.88 (607)	71.56 (1818)	-	-
445T / 300 hp	.19 (5)	98.38 (2499)	37.00 (940)	20.69 (526)	24.13 (613)	19.00 (483)	18.00 (457)	53.38 (1356)	44.75 (1137)	18.25 (464)	13.75 (349)	37.88 (962)	12.31 (313)	4	.91 (23)	6.25 (159)	4.00 (102)	63.56 (1614)	21.56 (548)	23.88 (607)	71.56 (1818)	-	-
449T / 350 hp	.19 (5)	98.38 (2499)	37.00 (940)	20.69 (526)	24.13 (613)	19.00 (483)	18.00 (457)	53.38 (1356)	44.75 (1137)	18.25 (464)	13.75 (349)	37.88 (962)	12.31 (313)	4	.91 (23)	6.25 (159)	4.00 (102)	71.81 (1824)	21.56 (548)	23.88 (607)	79.81 (2027)	-	-
449T / 400 hp	.19 (5)	98.38 (2499)	37.00 (940)	20.69 (526)	24.13 (613)	19.00 (483)	18.00 (457)	53.38 (1356)	44.75 (1137)	18.25 (464)	13.75 (349)	37.88 (962)	12.31 (313)	4	.91 (23)	6.25 (159)	4.00 (102)	71.81 (1824)	21.56 (548)	23.88 (607)	79.81 (2027)	-	-

Flange Dimensions – Suction Side

Dimensions - Inches (mm)

DN S #125	ØD	Ød	Øk	b	n	D2
10	16.00 (406)	12.75 (324)	14.25 (362)	1.19 (30)	12	1.00 (25)

Flange Dimensions – Discharge Side

Dimensions - Inches (mm)

DND 125#	ØD	Ød	Øk	b	n	D2
8	13.50 (343)	10.63 (270)	11.75 (298)	1.13 (29)	8	.88 (22)

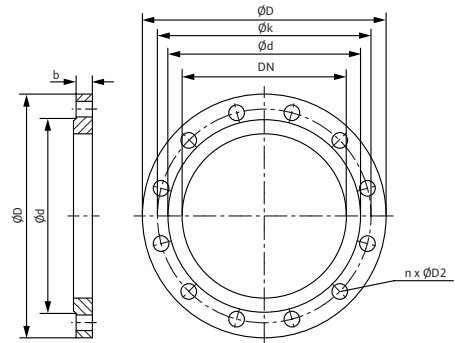

Submittal Data Sheet

Wilo SCP – Horizontal Split Case Pumps



SCP 10 x 8 x 22 HA

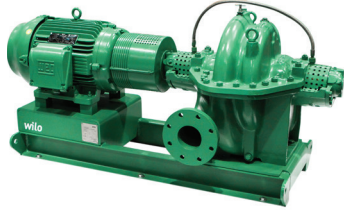

Project:	
Engineer:	
Contractor:	
Submitted By:	Date:
Approved By:	Date:

Tag #	Model #	Flow (USGPM)	Head (Feet)	HP	Enclosure TEFC/ODP	Frame	Cycle	Phase	Voltage	RPM
	SCP 10 x 8 x 22 HA						60 Hz	3		

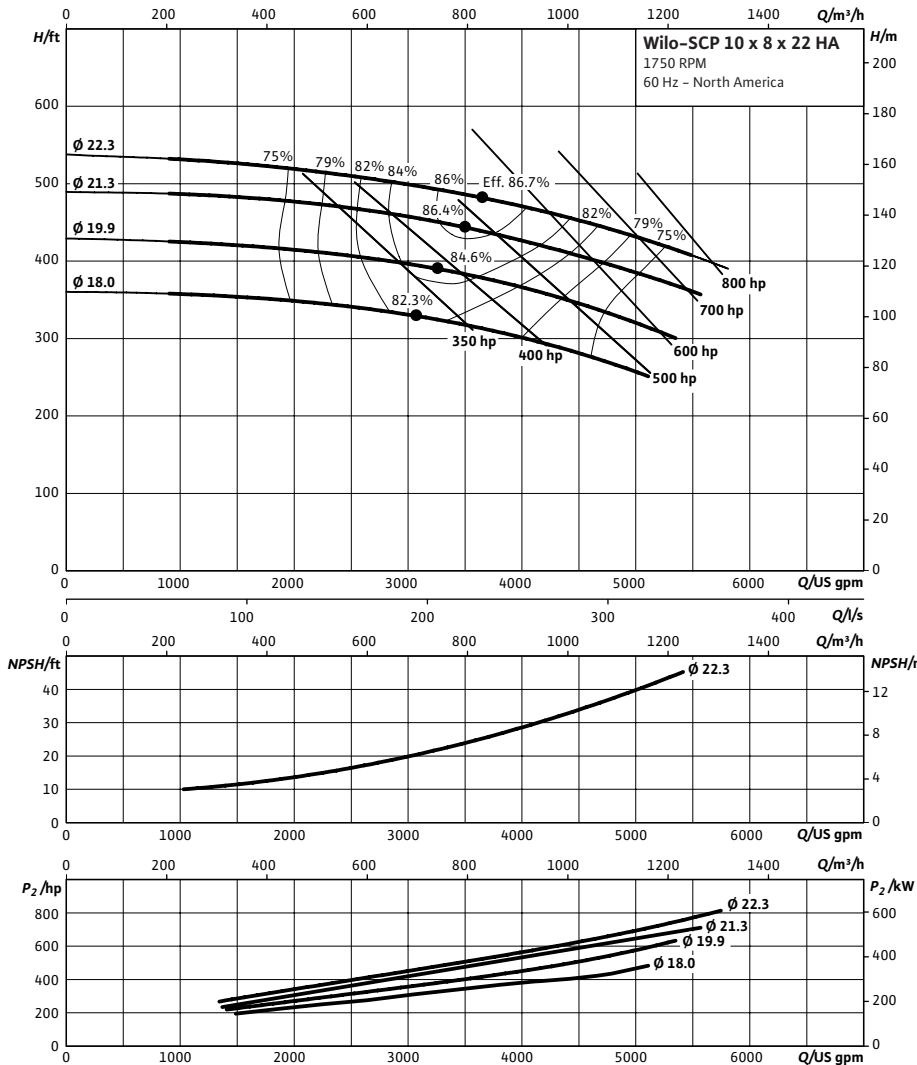

Technical Data

Approved Fluids
 Heating Water
 Cooling and cold water
 Water-Glycol mixtures (for 20-40% glycol and fluid temp ≤ 104°F [40°C])

Fluid Temperature
 Mechanical Seal: 18°F to 250°F (-8°C to 120°C)
 Stuffing Box Packing: 18°F to 220°F (-8°C to 105°C)

Materials of Construction

<input type="checkbox"/> Pump Housing	A48 Class 35
<input type="checkbox"/> Pump Housing (Optional)	Ni-resist BS 3468 Gr 2 / BS 2789 500.1
<input type="checkbox"/> Impeller	BS 84 C83 600
<input type="checkbox"/> Impeller (optional)	A48 Class 35 / BS 84 C83 600
<input type="checkbox"/> Stationary Wear Rings	BS 84 C93 700
<input type="checkbox"/> Pump Shaft	A276 type 410
<input type="checkbox"/> Pump Shaft (optional)	BS 970 316 S16
<input type="checkbox"/> Mechanical Seal	Carbon/silicon carbide/EPDM (E1)
<input type="checkbox"/> Other Mechanical Seals	Avail. on request
<input type="checkbox"/> Additional Spacer Coupling	Avail. on request
<input type="checkbox"/> Other:	

Approval Stamp

Dimensional Drawing

Single Stage Pump

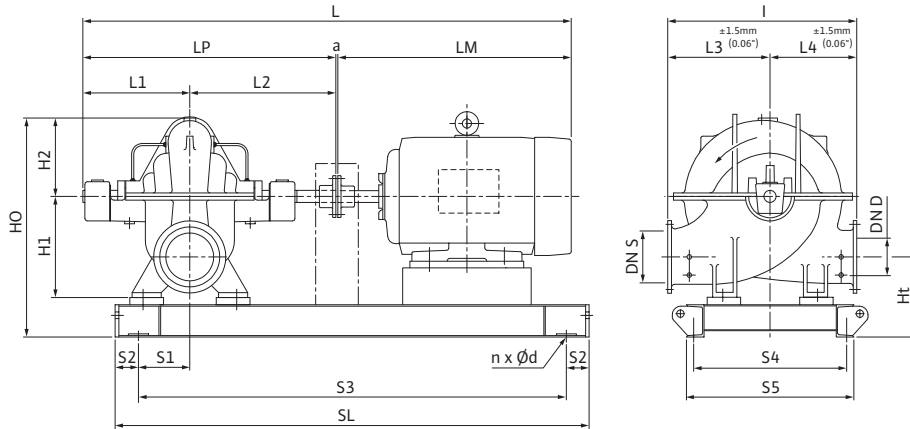

SCP 10 x 8 x 22 HA

Dimensions - Inches (mm)

Frame	a	L	l	L1	L2	L3	L4	LM	LP	H1	H2	HO	Ht	n	Ød	S1	S2	S3	S4	S5	SL	P5	P6
449T / 350 hp	.19 (5)	104.25 (2648)	38.56 (979)	23.38 (954)	27.31 (694)	20.50 (521)	18.06 (459)	23.38 (1356)	20.69 (1288)	21.50 (546)	15.56 (395)	44.00 (1118)	14.44 (367)	4	.91 (23)	9.75 (248)	4.00 (102)	78.50 (1994)	23.63 (600)	26.38 (670)	86.50 (2197)	-	-
449T / 400 hp	.19 (5)	104.25 (2648)	38.56 (979)	23.38 (954)	27.31 (694)	20.50 (521)	18.06 (459)	23.38 (1356)	20.69 (1288)	21.50 (546)	15.56 (395)	44.00 (1118)	14.44 (367)	4	.91 (23)	9.75 (248)	4.00 (102)	78.50 (1994)	23.63 (600)	26.38 (670)	86.50 (2197)	-	-

Flange Dimensions – Suction Side

Dimensions - Inches (mm)

DN S #125	ØD	Ød	Øk	b	n	D2
10	16.00 (406)	12.75 (324)	14.25 (362)	1.19 (30)	12	1.00 (25)

Flange Dimensions – Discharge Side

Dimensions - Inches (mm)

DN D 125#	ØD	Ød	Øk	b	n	D2
8	13.50 (343)	10.63 (270)	11.75 (298)	1.13 (29)	8	.88 (22)

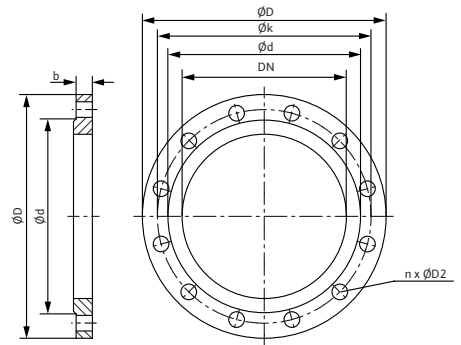

Submittal Data Sheet

Wilo SCP – Horizontal Split Case Pumps



SCP 10 x 10 x 9½ HA

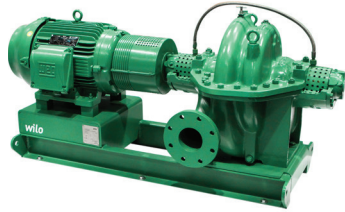

Project:	
Engineer:	
Contractor:	
Submitted By:	Date:
Approved By:	Date:

Tag #	Model #	Flow (USGPM)	Head (Feet)	HP	Enclosure TEFC/ODP	Frame	Cycle	Phase	Voltage	RPM
	SCP 10 x 10 x 9½ HA						60 Hz	3		

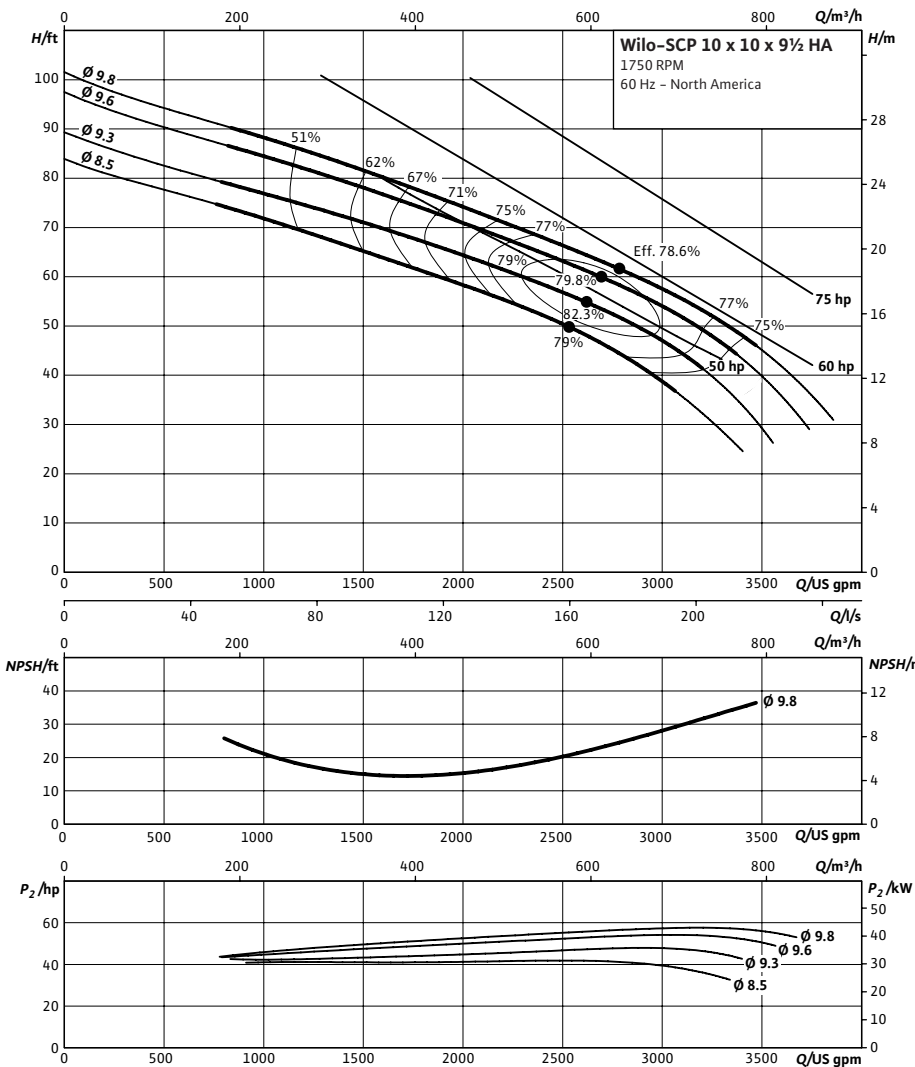

Technical Data

Approved Fluids
 Heating Water
 Cooling and cold water
 Water-Glycol mixtures (for 20-40% glycol and fluid temp ≤ 104°F [40°C])

Fluid Temperature
 Mechanical Seal: 18°F to 250°F (-8°C to 120°C)
 Stuffing Box Packing: 18°F to 220°F (-8°C to 105°C)

Materials of Construction

<input type="checkbox"/> Pump Housing	A48 Class 35
<input type="checkbox"/> Pump Housing (Optional)	Ni-resist BS 3468 Gr 2 / BS 2789 500.1
<input type="checkbox"/> Impeller	BS 84 C83 600
<input type="checkbox"/> Impeller (optional)	A48 Class 35 / BS 84 C83 600
<input type="checkbox"/> Stationary Wear Rings	BS 84 C93 700
<input type="checkbox"/> Pump Shaft	A276 type 410
<input type="checkbox"/> Pump Shaft (optional)	BS 970 316 S16
<input type="checkbox"/> Mechanical Seal	Carbon/silicon carbide/EPDM (E1)
<input type="checkbox"/> Other Mechanical Seals	Avail. on request
<input type="checkbox"/> Additional Spacer Coupling	Avail. on request
<input type="checkbox"/> Other:	

Approval Stamp

Dimensional Drawing

Single Stage Pump

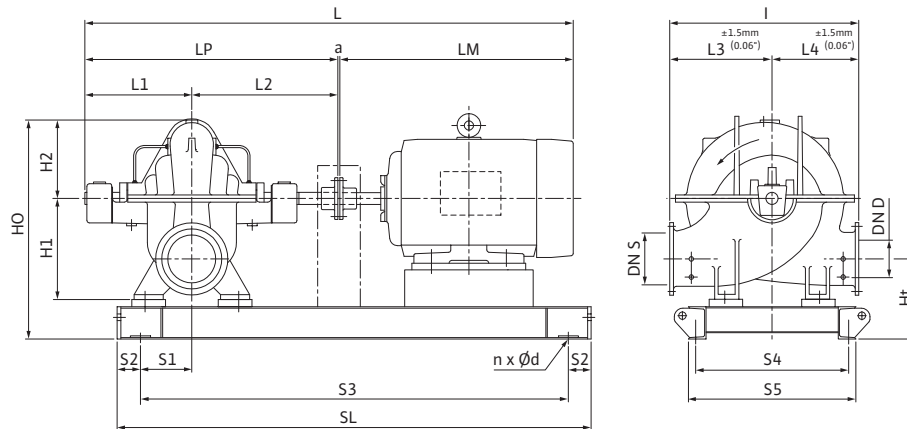

SCP 10 x 10 x 9½ HA

Dimensions - Inches (mm)																							
Frame	a	L	I	L1	L2	L3	L4	LM	LP	H1	H2	HO	Ht	n	Ød	S1	S2	S3	S4	S5	SL	P5	P6
326T	.50 (13)	65.13 (1654)	24.81 (630)	15.63 (397)	18.63 (473)	14.56 (370)	10.25 (260)	30.38 (772)	34.25 (870)	16.13 (410)	10.44 (265)	32.19 (818)	13.00 (330)	4	.91 (23)	6.25 (159)	4.00 (102)	46.75 (1187)	14.31 (363)	16.63 (422)	54.75 (1391)	-	-
364T	.50 (13)	67.74 (1721)	24.81 (630)	15.63 (397)	18.63 (473)	14.56 (370)	10.25 (260)	33.00 (838)	34.25 (870)	16.13 (410)	10.44 (265)	32.19 (818)	13.00 (330)	4	.91 (23)	6.25 (159)	4.00 (102)	48.25 (1226)	15.81 (402)	18.13 (461)	56.25 (1429)	-	-
365T	.50 (13)	67.74 (1721)	24.81 (630)	15.63 (397)	18.63 (473)	14.56 (370)	10.25 (260)	33.00 (838)	34.25 (870)	16.13 (410)	10.44 (265)	32.19 (818)	13.00 (330)	4	.91 (23)	6.25 (159)	4.00 (102)	48.25 (1226)	15.81 (402)	18.13 (461)	56.25 (1429)	-	-

Flange Dimensions – Suction Side

Dimensions - Inches (mm)						
DN S #125	ØD	Ød	Øk	b	n	D2
10	16.00 (406)	12.75 (324)	14.25 (362)	1.19 (30)	12	1.00 (25)

Flange Dimensions – Discharge Side

Dimensions - Inches (mm)						
DND 125#	ØD	Ød	Øk	b	n	D2
10	16.00 (406)	12.75 (324)	14.25 (362)	1.19 (30)	12	1.00 (25)

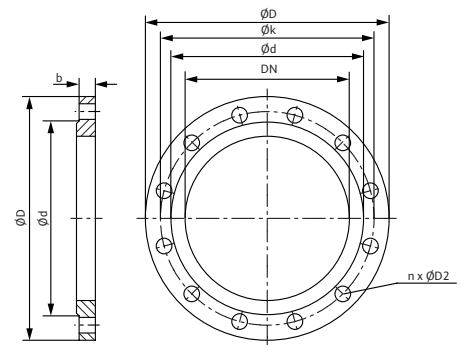

Submittal Data Sheet

Wilo SCP – Horizontal Split Case Pumps



SCP 12 x 8 x 14 HB

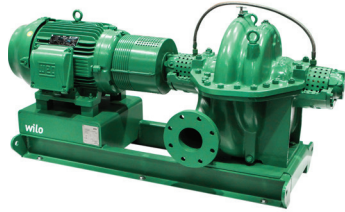

Project:	
Engineer:	
Contractor:	
Submitted By:	Date:
Approved By:	Date:

Tag #	Model #	Flow (USGPM)	Head (Feet)	HP	Enclosure TEFC/ODP	Frame	Cycle	Phase	Voltage	RPM
	SCP 12 x 8 x 14 HB						60 Hz	3		

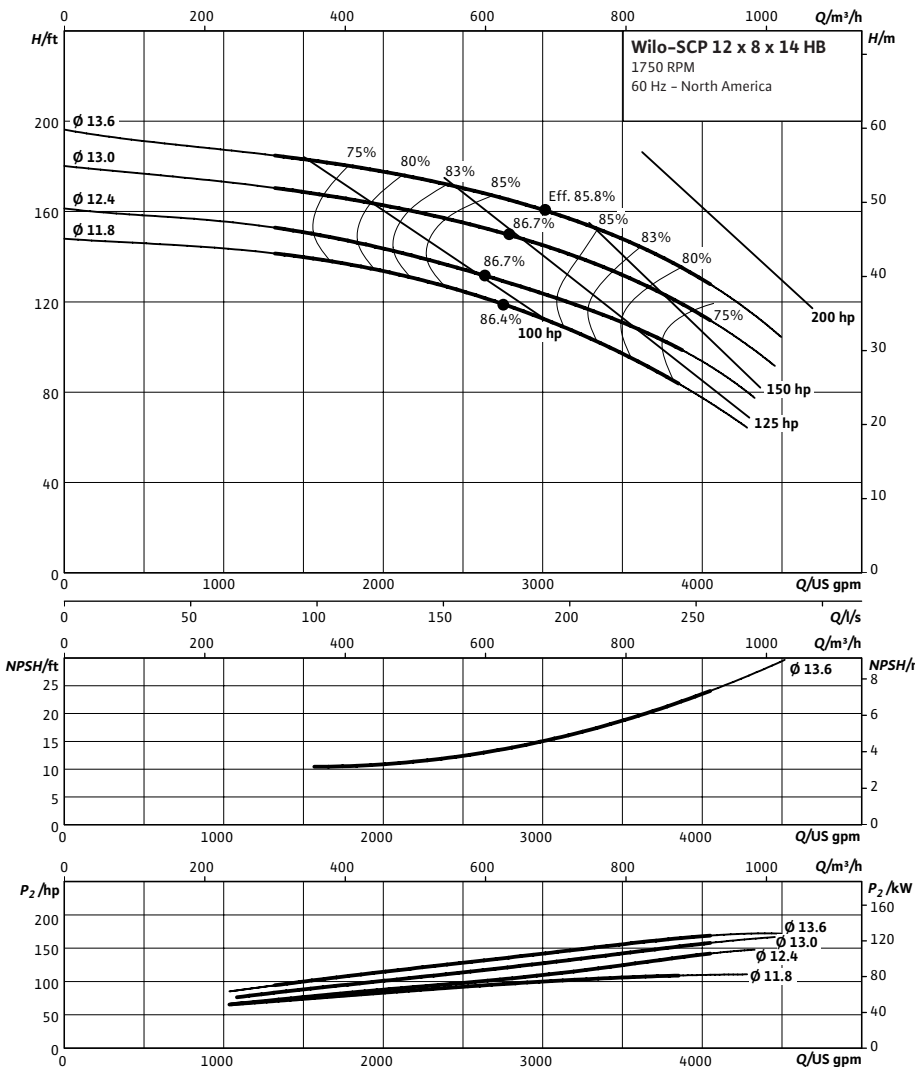

Technical Data

Approved Fluids
 Heating Water
 Cooling and cold water
 Water-Glycol mixtures (for 20-40% glycol and fluid temp ≤ 104°F [40°C])

Fluid Temperature
 Mechanical Seal: 18°F to 250°F (-8°C to 120°C)
 Stuffing Box Packing: 18°F to 220°F (-8°C to 105°C)

Materials of Construction

<input type="checkbox"/> Pump Housing	A48 Class 35
<input type="checkbox"/> Pump Housing (Optional)	Ni-resist BS 3468 Gr 2 / BS 2789 500.1
<input type="checkbox"/> Impeller	BS 84 C83 600
<input type="checkbox"/> Impeller (optional)	A48 Class 35 / BS 84 C83 600
<input type="checkbox"/> Stationary Wear Rings	BS 84 C93 700
<input type="checkbox"/> Pump Shaft	A276 type 410
<input type="checkbox"/> Pump Shaft (optional)	BS 970 316 S16
<input type="checkbox"/> Mechanical Seal	Carbon/silicon carbide/EPDM (E1)
<input type="checkbox"/> Other Mechanical Seals	Avail. on request
<input type="checkbox"/> Additional Spacer Coupling	Avail. on request
<input type="checkbox"/> Other:	

Approval Stamp

Dimensional Drawing

Single Stage Pump

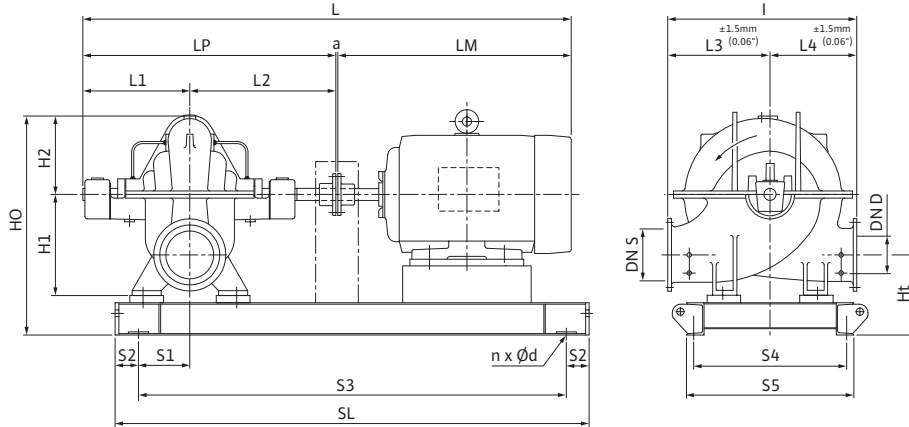

SCP 12 x 8 x 14 HB

Dimensions - Inches (mm)

Frame	a	L	I	L1	L2	L3	L4	LM	LP	H1	H2	HO	Ht	n	Ød	S1	S2	S3	S4	S5	SL	P5	P6
404T	.50 (13)	78.81 (2002)	32.31 (821)	19.06 (484)	22.06 (560)	18.50 (470)	13.75 (349)	37.25 (946)	41.13 (1045)	17.69 (449)	12.63 (321)	36.13 (918)	12.63 (321)	4	.91 (23)	6.25 (159)	4.00 (102)	55.63 (1413)	18.94 (481)	21.31 (541)	63.63 (1616)	-	-
405T	.50 (13)	85.88 (2181)	32.31 (821)	19.06 (484)	22.06 (560)	18.50 (470)	13.75 (349)	44.25 (1124)	41.13 (1045)	17.69 (449)	12.63 (321)	36.13 (918)	12.63 (321)	4	.91 (23)	6.25 (159)	4.00 (102)	55.63 (1413)	18.94 (481)	21.31 (541)	63.63 (1616)	-	-
444T	.50 (13)	85.88 (2181)	32.31 (821)	19.06 (484)	22.06 (560)	18.50 (470)	13.75 (349)	44.25 (1124)	41.13 (1045)	17.69 (449)	12.63 (321)	36.13 (918)	12.63 (321)	4	.91 (23)	6.25 (159)	4.00 (102)	60.81 (1545)	21.56 (548)	23.88 (607)	68.81 (1748)	-	-
445T	.50 (13)	85.88 (2181)	32.31 (821)	19.06 (484)	22.06 (560)	18.50 (470)	13.75 (349)	44.25 (1124)	41.13 (1045)	17.69 (449)	12.63 (321)	36.13 (918)	12.63 (321)	4	.91 (23)	6.25 (159)	4.00 (102)	60.81 (1545)	21.56 (548)	23.88 (607)	68.81 (1748)	-	-

Flange Dimensions – Suction Side

Dimensions - Inches (mm)

DN S #125	ØD	Ød	Øk	b	n	D2
12	19 (483)	15.00 (381)	17.00 (432)	1.25 (32)	12	1.00 (25)

Flange Dimensions – Discharge Side

Dimensions - Inches (mm)

DN D 125#	ØD	Ød	Øk	b	n	D2
8	13.50 (343)	10.63 (270)	11.75 (298)	1.13 (29)	8	.88 (22)

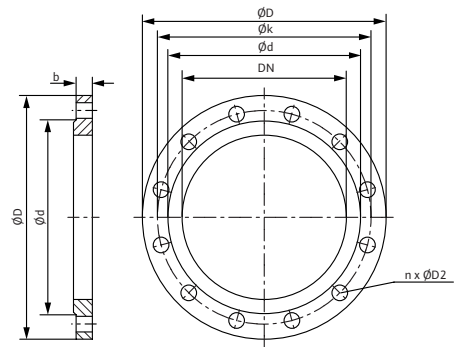

Submittal Data Sheet

Wilco SCP - Horizontal Split Case Pumps



SCP 12 x 10 x 14 HA

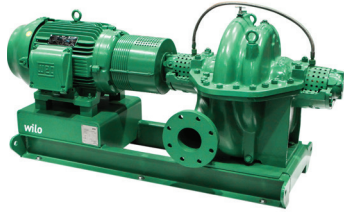

Project:	
Engineer:	
Contractor:	
Submitted By:	Date:
Approved By:	Date:

Tag #	Model #	Flow (USGPM)	Head (Feet)	HP	Enclosure TEFC/ODP	Frame	Cycle	Phase	Voltage	RPM
	SCP 12 x 10 x 14 HA						60 Hz	3		

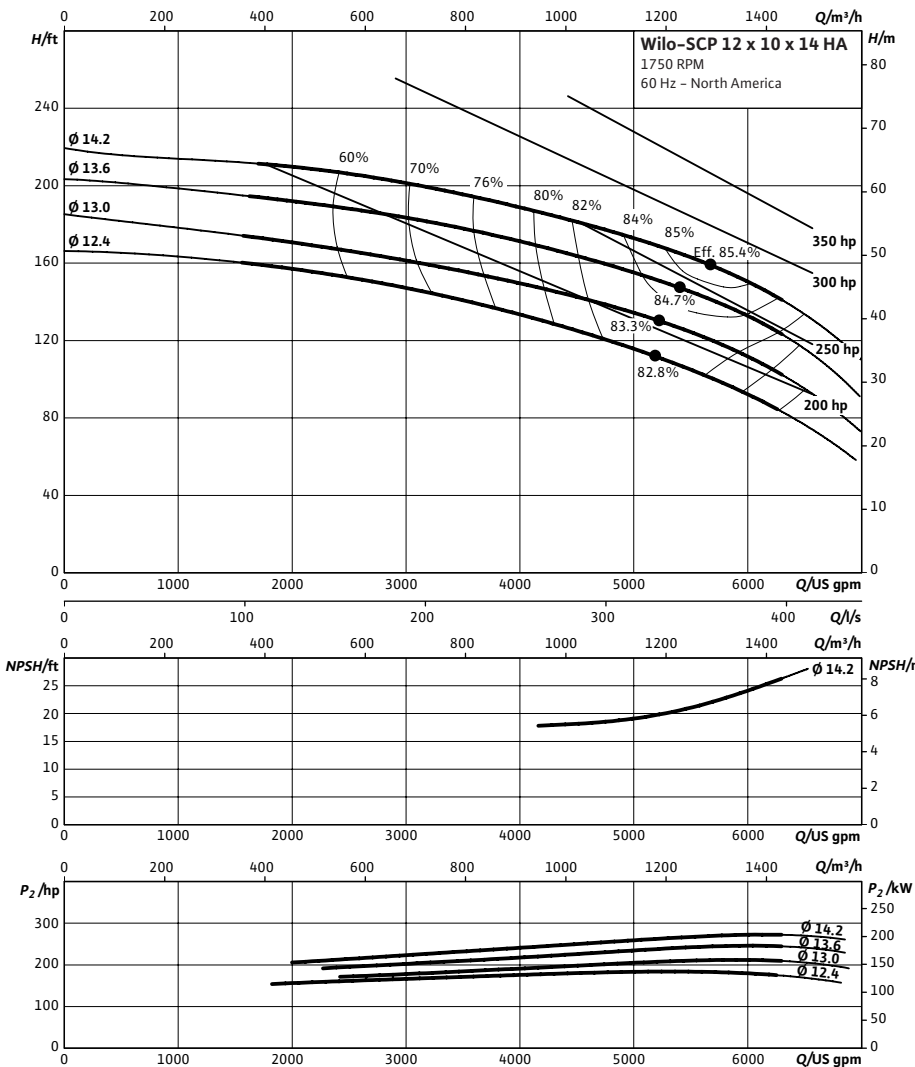

Technical Data

Approved Fluids

- Heating Water
- Cooling and cold water
- Water-Glycol mixtures (for 20-40% glycol and fluid temp \leq 104°F [40°C])

Fluid Temperature

- Mechanical Seal: 18°F to 250°F (-8°C to 120°C)
- Stuffing Box Packing: 18°F to 220°F (-8°C to 105°C)

Materials of Construction

<input type="checkbox"/> Pump Housing	A48 Class 35
<input type="checkbox"/> Pump Housing (Optional)	Ni-resist BS 3468 Gr 2 / BS 2789 500.1
<input type="checkbox"/> Impeller	BS 84 C83 600
<input type="checkbox"/> Impeller (optional)	A48 Class 35 / BS 84 C83 600
<input type="checkbox"/> Stationary Wear Rings	BS 84 C93 700
<input type="checkbox"/> Pump Shaft	A276 type 410
<input type="checkbox"/> Pump Shaft (optional)	BS 970 316 S16
<input type="checkbox"/> Mechanical Seal	Carbon/silicon carbide/EPDM (E1)
<input type="checkbox"/> Other Mechanical Seals	Avail. on request
<input type="checkbox"/> Additional Spacer Coupling	Avail. on request
<input type="checkbox"/> Other:	

Approval Stamp

Dimensional Drawing

Single Stage Pump

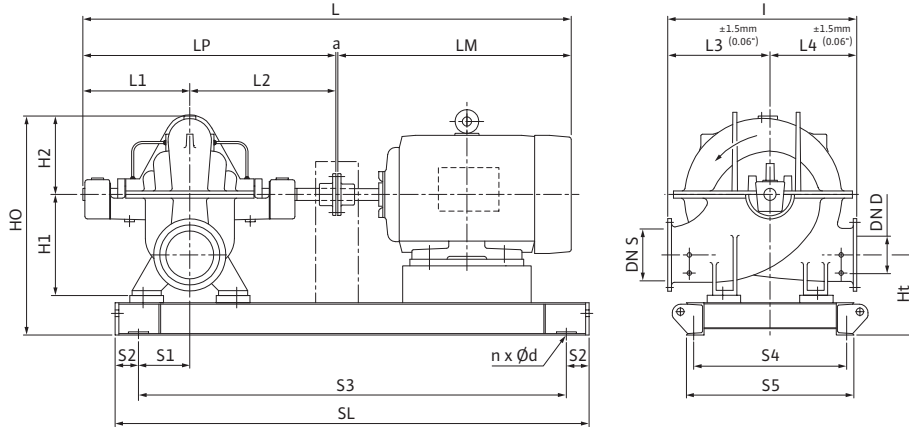

SCP 12 x 10 x 14 HA

Dimensions - Inches (mm)

Frame	a	L	I	L1	L2	L3	L4	LM	LP	H1	H2	HO	Ht	n	Ød	S1	S2	S3	S4	S5	SL	P5	P6
445T / 200 hp	.50 (13)	89.13 (2264)	35.31 (897)	19.88 (505)	24.50 (622)	20.38 (518)	14.94 (380)	44.25 (1124)	44.38 (1127)	21.25 (540)	13.38 (340)	40.44 (1027)	14.44 (367)	4	.91 (23)	8.19 (208)	4.00 (102)	65.19 (1656)	21.56 (548)	23.88 (607)	73.19 (1859)	-	-
445T / 250 hp	.19 (5)	95.31 (2340)	35.31 (897)	19.88 (505)	24.50 (622)	20.38 (518)	14.94 (380)	47.75 (1213)	44.38 (1127)	21.25 (540)	13.38 (340)	40.44 (1027)	14.44 (367)	4	.91 (23)	8.19 (208)	4.00 (102)	65.81 (1672)	21.56 (548)	23.88 (607)	73.94 (1878)	-	-
445T / 300 hp	.19 (5)	98.00 (2489)	35.31 (897)	19.88 (505)	24.50 (622)	20.38 (518)	14.94 (380)	53.38 (1356)	44.38 (1127)	21.25 (540)	13.38 (340)	40.44 (1027)	14.44 (367)	4	.91 (23)	8.19 (208)	4.00 (102)	65.81 (1672)	21.56 (548)	23.88 (607)	73.94 (1878)	-	-
449T / 350 hp	.19 (5)	98.00 (2489)	35.31 (897)	19.88 (505)	24.50 (622)	20.38 (518)	14.94 (380)	53.38 (1356)	44.38 (1127)	21.25 (540)	13.38 (340)	40.44 (1027)	14.44 (367)	4	.91 (23)	8.19 (208)	4.00 (102)	74.19 (1884)	21.06 (535)	23.38 (593)	82.19 (2088)	-	-

Flange Dimensions – Suction Side

Dimensions - Inches (mm)

DN S #125	ØD	Ød	Øk	b	n	D2
12	19 (483)	15.00 (381)	17.00 (432)	1.25 (32)	12	1.00 (25)

Flange Dimensions – Discharge Side

Dimensions - Inches (mm)

DN D 125#	ØD	Ød	Øk	b	n	D2
10	16.00 (406)	12.75 (324)	14.25 (362)	1.81 (30.16)	12	1.00 (25)

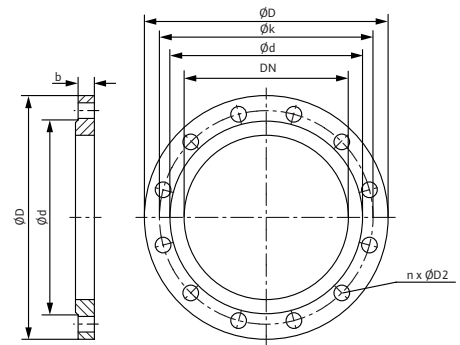

Submittal Data Sheet

Wilco SCP – Horizontal Split Case Pumps



SCP 12 x 10 x 15 HA

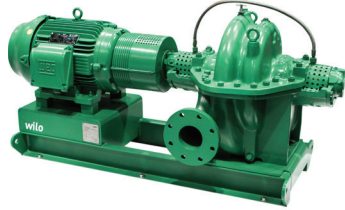

Project:	
Engineer:	
Contractor:	
Submitted By:	Date:
Approved By:	Date:

Tag #	Model #	Flow (USGPM)	Head (Feet)	HP	Enclosure TEFC/ODP	Frame	Cycle	Phase	Voltage	RPM
	SCP 12 x 10 x 15 HA						60 Hz	3		

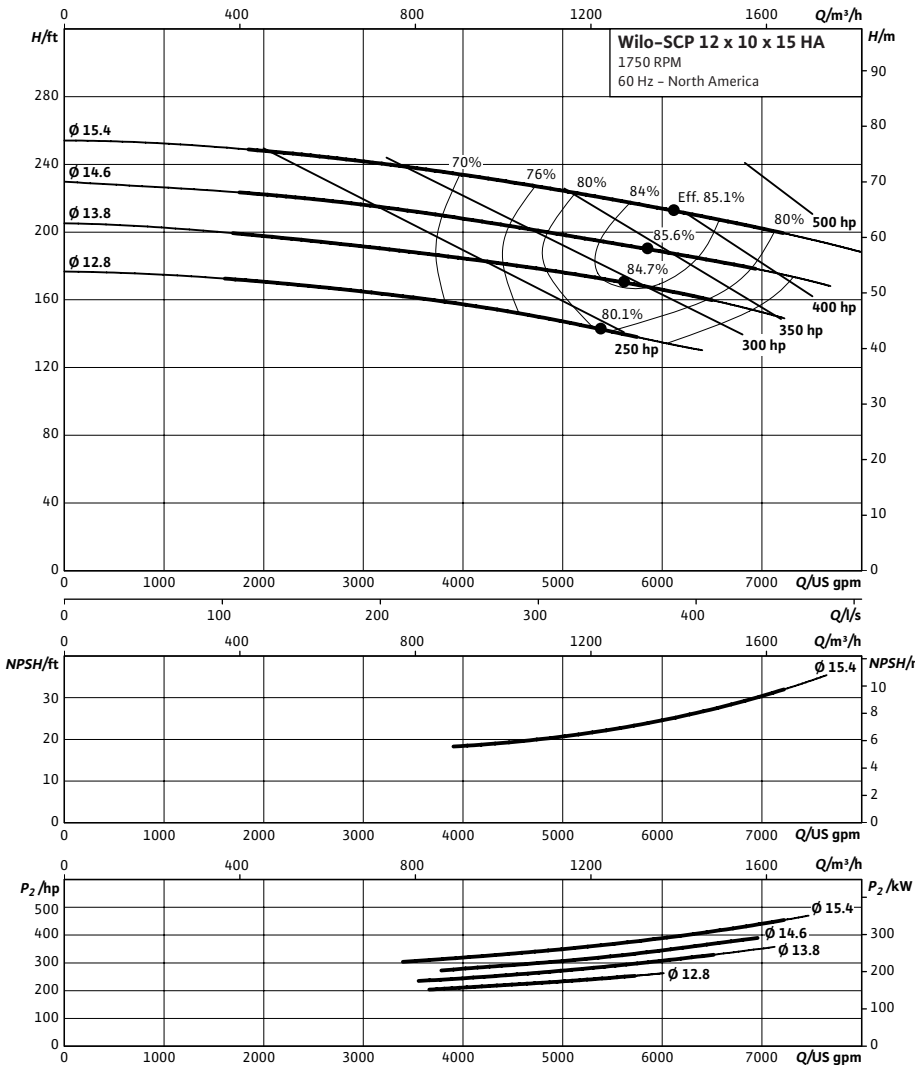

Technical Data

Approved Fluids
 Heating Water
 Cooling and cold water
 Water-Glycol mixtures (for 20–40% glycol and fluid temp ≤ 104°F [40°C])

Fluid Temperature
 Mechanical Seal: 18°F to 250°F (–8°C to 120°C)
 Stuffing Box Packing: 18°F to 220°F (–8°C to 105°C)

Materials of Construction

<input type="checkbox"/> Pump Housing	A48 Class 35
<input type="checkbox"/> Pump Housing (Optional)	Ni-resist BS 3468 Gr 2 / BS 2789 500.1
<input type="checkbox"/> Impeller	BS 84 C83 600
<input type="checkbox"/> Impeller (optional)	A48 Class 35 / BS 84 C83 600
<input type="checkbox"/> Stationary Wear Rings	BS 84 C93 700
<input type="checkbox"/> Pump Shaft	A276 type 410
<input type="checkbox"/> Pump Shaft (optional)	BS 970 316 S16
<input type="checkbox"/> Mechanical Seal	Carbon/silicon carbide/EPDM (E1)
<input type="checkbox"/> Other Mechanical Seals	Avail. on request
<input type="checkbox"/> Additional Spacer Coupling	Avail. on request
<input type="checkbox"/> Other:	

Approval Stamp

Dimensional Drawing

Single Stage Pump

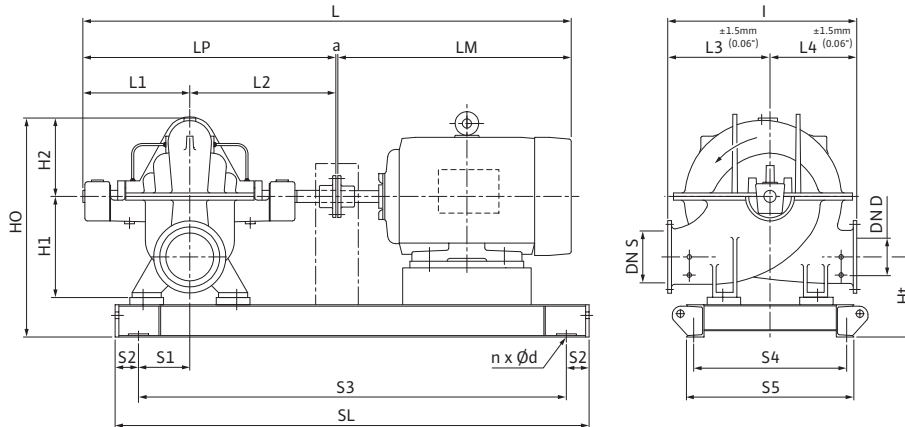

SCP 12 x 10 x 15 HA

Dimensions - Inches (mm)

Frame	a	L	I	L1	L2	L3	L4	LM	LP	H1	H2	HO	Ht	n	Ød	S1	S2	S3	S4	S5	SL	P5	P6
445T / 250 hp	.19 (5)	92.31 (2345)	35.31 (897)	19.88 (505)	24.50 (622)	20.38 (518)	14.94 (380)	47.75 (1213)	44.38 (1127)	21.25 (540)	13.38 (340)	40.44 (1027)	14.44 (367)	4	.91 (23)	8.19 (208)	4.00 (102)	65.81 (1672)	21.56 (548)	23.88 (607)	73.94 (1878)	-	-
445T / 300 hp	.19 (5)	98.00 (2489)	35.31 (897)	19.88 (505)	24.50 (622)	20.38 (518)	14.94 (380)	53.38 (1356)	44.38 (1127)	21.25 (540)	13.38 (340)	40.44 (1027)	14.44 (367)	4	.91 (23)	8.19 (208)	4.00 (102)	65.81 (1672)	21.56 (548)	23.88 (607)	73.94 (1878)	-	-
449T / 350 hp	.19 (5)	98.00 (2489)	35.31 (897)	19.88 (505)	24.50 (622)	20.38 (518)	14.94 (380)	53.38 (1356)	44.38 (1127)	21.25 (540)	13.38 (340)	40.44 (1027)	14.44 (367)	4	.91 (23)	8.19 (208)	4.00 (102)	74.19 (1884)	21.06 (535)	23.38 (593)	82.19 (2088)	-	-
449T / 400 hp	.19 (5)	98.00 (2489)	35.31 (897)	19.88 (505)	24.50 (622)	20.38 (518)	14.94 (380)	53.38 (1356)	44.38 (1127)	21.25 (540)	13.38 (340)	40.44 (1027)	14.44 (367)	4	.91 (23)	8.19 (208)	4.00 (102)	74.19 (1884)	21.06 (535)	23.38 (593)	82.19 (2088)	-	-

Flange Dimensions – Suction Side

Dimensions - Inches (mm)

DN S #125	ØD	Ød	Øk	b	n	D2
12	19 (483)	15.00 (381)	17.00 (432)	1.25 (32)	12	1.00 (25)

Flange Dimensions – Discharge Side

Dimensions - Inches (mm)

DN D 125#	ØD	Ød	Øk	b	n	D2
10	16.00 (406)	12.75 (324)	14.25 (362)	1.81 (30.16)	12	1.00 (25)

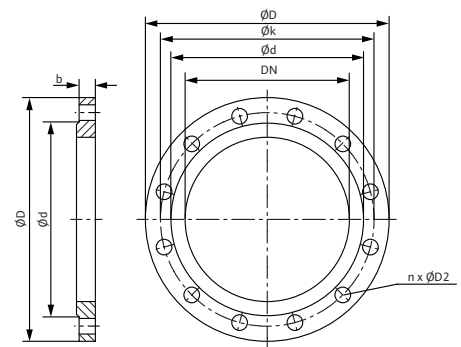

Submittal Data Sheet

Wilco SCP - Horizontal Split Case Pumps



SCP 12 x 10 x 17½ HA

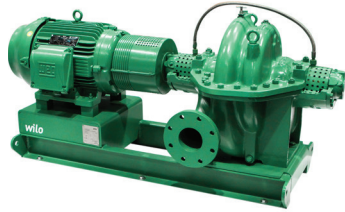

Project:	
Engineer:	
Contractor:	
Submitted By:	Date:
Approved By:	Date:

Tag #	Model #	Flow (USGPM)	Head (Feet)	HP	Enclosure TEFC/ODP	Frame	Cycle	Phase	Voltage	RPM
	SCP 12 x 10 x 17½ HA						60 Hz	3		

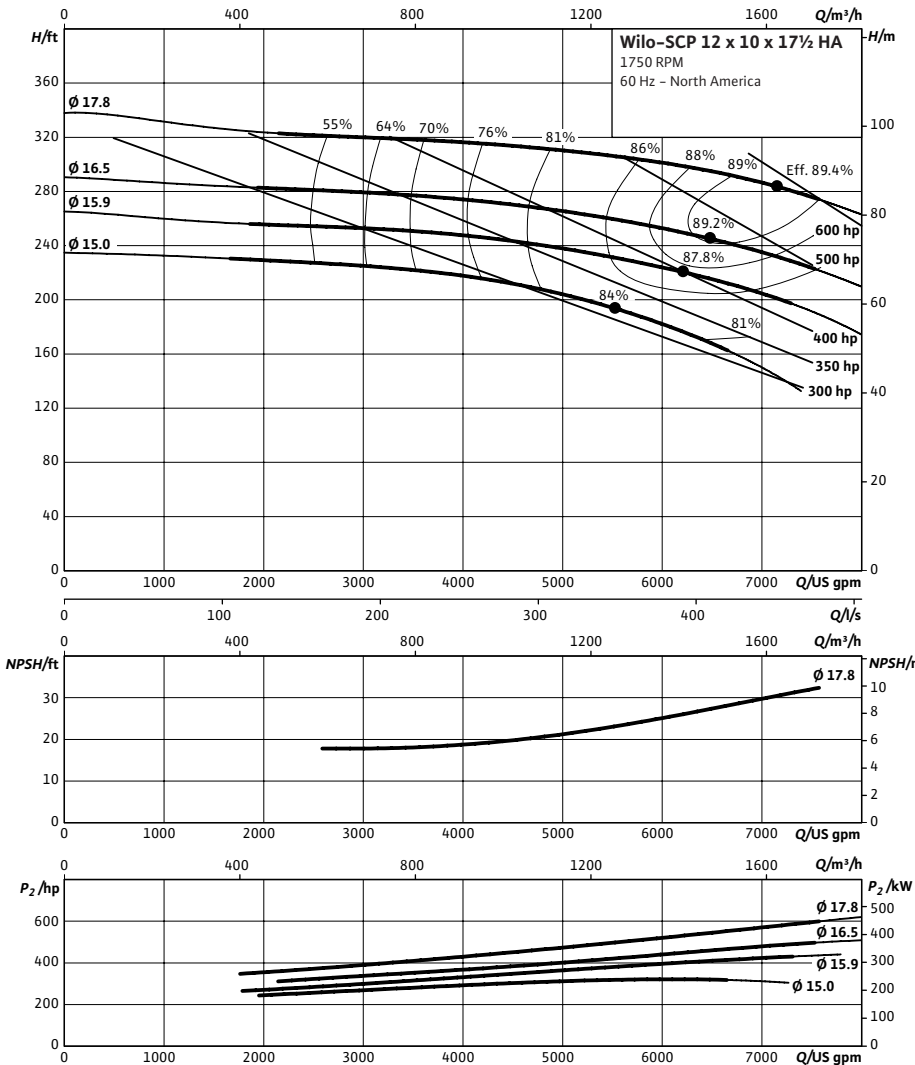

Technical Data

Approved Fluids

Heating Water
Cooling and cold water

Water-Glycol mixtures (for 20-40% glycol and fluid temp ≤ 104°F [40°C])

Fluid Temperature

Mechanical Seal: 18°F to 250°F (-8°C to 120°C)
Stuffing Box Packing: 18°F to 220°F (-8°C to 105°C)

Materials of Construction

<input type="checkbox"/>	Pump Housing	A48 Class 35
<input type="checkbox"/>	Pump Housing (Optional)	Ni-resist BS 3468 Gr 2 / BS 2789 500.1
<input type="checkbox"/>	Impeller	BS 84 C83 600
<input type="checkbox"/>	Impeller (optional)	A48 Class 35 / BS 84 C83 600
<input type="checkbox"/>	Stationary Wear Rings	BS 84 C93 700
<input type="checkbox"/>	Pump Shaft	A276 type 410
<input type="checkbox"/>	Pump Shaft (optional)	BS 970 316 S16
<input type="checkbox"/>	Mechanical Seal	Carbon/silicon carbide/EPDM (E1)
<input type="checkbox"/>	Other Mechanical Seals	Avail. on request
<input type="checkbox"/>	Additional Spacer Coupling	Avail. on request
<input type="checkbox"/>	Other:	

Approval Stamp

Dimensional Drawing

Single Stage Pump

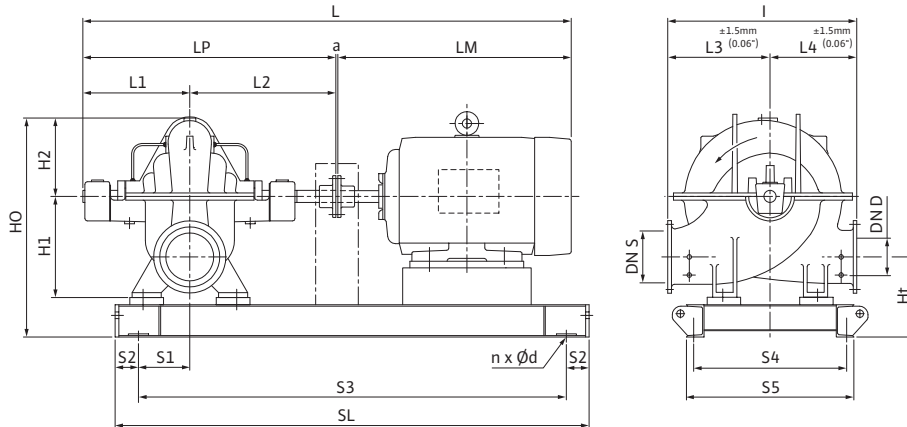

SCP 12 x 10 x 17½ HA

Dimensions – Inches (mm)

Frame	a	L	I	L1	L2	L3	L4	LM	LP	H1	H2	HO	Ht	n	Ød	S1	S2	S3	S4	S5	SL	P5	P6
445T/ 300 hp	.19 (5)	104.25 (2648)	39.00 (991)	23.38 (594)	27.31 (694)	21.00 (533)	18.00 (457)	53.38 (1356)	50.69 (1288)	21.50 (546)	14.94 (379)	43.38 (1102)	14.94 (379)	4	.91 (23)	9.75 (248)	4.00 (102)	70.25 (1784)	23.63 (600)	26.38 (670)	78.25 (1988)	-	-
449T/ 350 hp	.19 (5)	104.25 (2648)	39.00 (991)	23.38 (594)	27.31 (694)	21.00 (533)	18.00 (457)	53.38 (1356)	50.69 (1288)	21.50 (546)	14.94 (379)	43.38 (1102)	14.94 (379)	4	.91 (23)	9.75 (248)	4.00 (102)	78.50 (1994)	23.63 (600)	26.38 (670)	86.50 (2197)	-	-
449T/ 400 hp	.19 (5)	104.25 (2648)	39.00 (991)	23.38 (594)	27.31 (694)	21.00 (533)	18.00 (457)	53.38 (1356)	50.69 (1288)	21.50 (546)	14.94 (379)	43.38 (1102)	14.94 (379)	4	.91 (23)	9.75 (248)	4.00 (102)	78.50 (1994)	23.63 (600)	26.38 (670)	86.50 (2197)	-	-

Flange Dimensions – Suction Side

Dimensions – Inches (mm)

DN S #125	ØD	Ød	Øk	b	n	D2
12	19 (483)	15.00 (381)	17.00 (432)	1.25 (32)	12	1.00 (25)

Flange Dimensions – Discharge Side

Dimensions – Inches (mm)

DN D 125#	ØD	Ød	Øk	b	n	D2
10	16.00 (406)	12.75 (324)	14.25 (362)	1.81 (30.16)	12	1.00 (25)

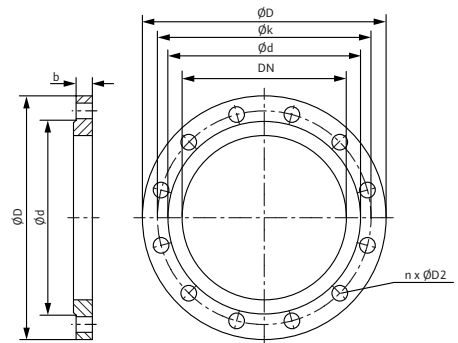

Submittal Data Sheet

Wilco SCP - Horizontal Split Case Pumps



SCP 12 x 10 x 22 HA

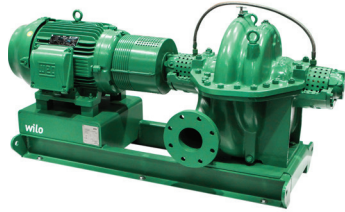

Project:	
Engineer:	
Contractor:	
Submitted By:	Date:
Approved By:	Date:

Tag #	Model #	Flow (USGPM)	Head (Feet)	HP	Enclosure TEFC/ODP	Frame	Cycle	Phase	Voltage	RPM
	SCP 12 x 10 x 22 HA						60 Hz	3		

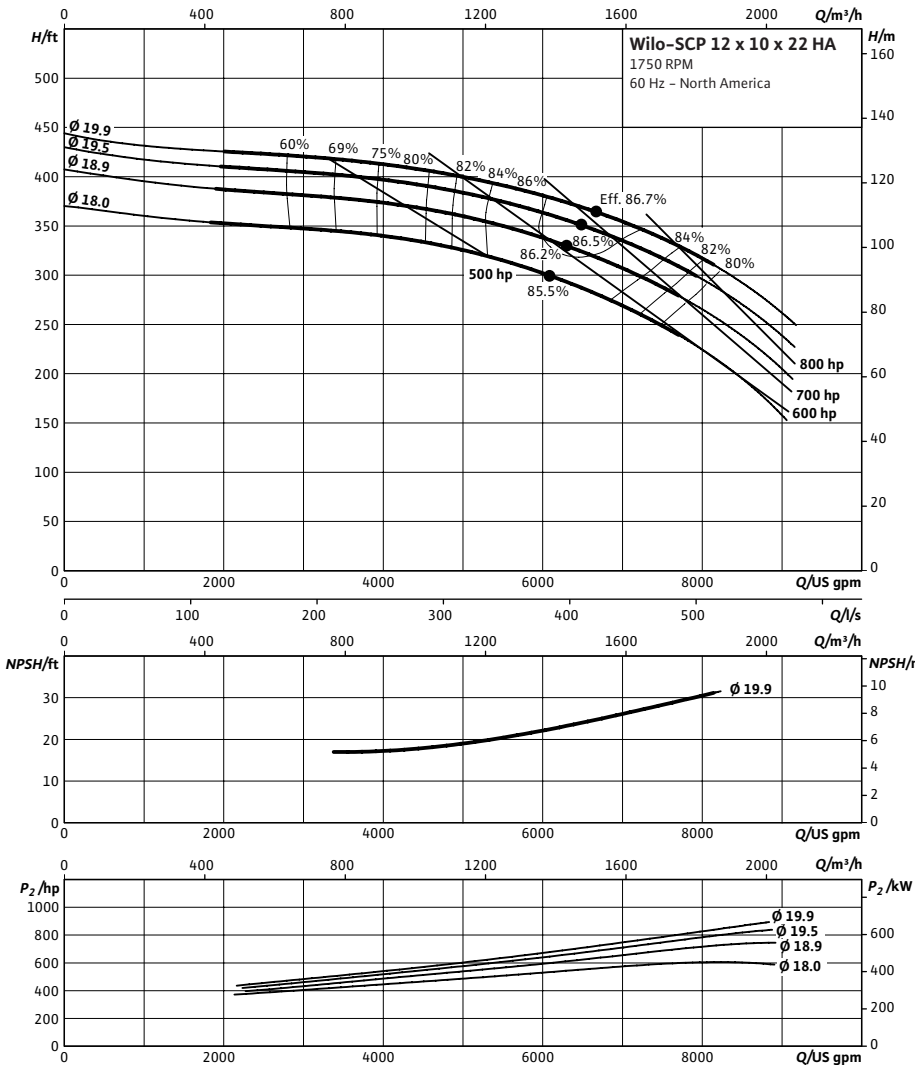

Technical Data

Approved Fluids	
Heating Water	
Cooling and cold water	
Water-Glycol mixtures (for 20-40% glycol and fluid temp $\leq 104^{\circ}\text{F}$ [40°C])	
Fluid Temperature	
Mechanical Seal	18°F to 250°F (-8°C to 120°C)
Stuffing Box Packing	18°F to 220°F (-8°C to 105°C)

Materials of Construction

<input type="checkbox"/> Pump Housing	A48 Class 35
<input type="checkbox"/> Pump Housing (Optional)	Ni-resist BS 3468 Gr 2 / BS 2789 500.1
<input type="checkbox"/> Impeller	BS 84 C83 600
<input type="checkbox"/> Impeller (optional)	A48 Class 35 / BS 84 C83 600
<input type="checkbox"/> Stationary Wear Rings	BS 84 C93 700
<input type="checkbox"/> Pump Shaft	A276 type 410
<input type="checkbox"/> Pump Shaft (optional)	BS 970 316 S16
<input type="checkbox"/> Mechanical Seal	Carbon/silicon carbide/EPDM (E1)
<input type="checkbox"/> Other Mechanical Seals	Avail. on request
<input type="checkbox"/> Additional Spacer Coupling	Avail. on request
<input type="checkbox"/> Other:	

Approval Stamp

Dimensional Drawing

Single Stage Pump

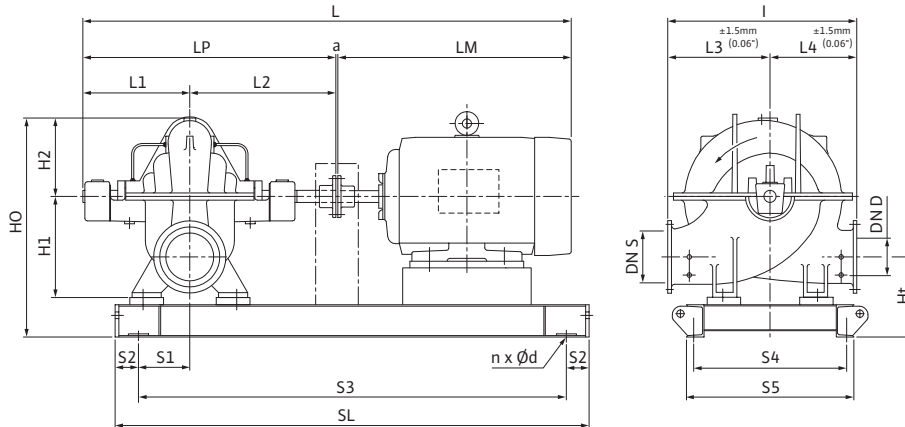

SCP 12 x 10 x 22 HA

Dimensions - Inches (mm)

Frame	a	L	I	L1	L2	L3	L4	LM	LP	H1	H2	HO	Ht	n	Ød	S1	S2	S3	S4	S5	SL	P5	P6
*	.19 (5)	*	39.00 (991)	23.38 (594)	27.25 (692)	23.00 (584)	19.38 (492)	*	50.69 (1288)	21.50 (546)	16.38 (416)	44.81 (1138)	14.44 (367)	*	*	9.75 (248)	4.00 (102)	*	*	*	*	-	-

* CONSULT FACTORY FOR MOTOR AND DIMENSIONS

Flange Dimensions – Suction Side

Dimensions - Inches (mm)

DN S #125	ØD	Ød	Øk	b	n	D2
12	19 (483)	15.00 (381)	17.00 (432)	1.25 (32)	12	1.00 (25)

Flange Dimensions – Discharge Side

Dimensions - Inches (mm)

DN D 125#	ØD	Ød	Øk	b	n	D2
10	16.00 (406)	12.75 (324)	14.25 (362)	1.81 (30.16)	12	1.00 (25)

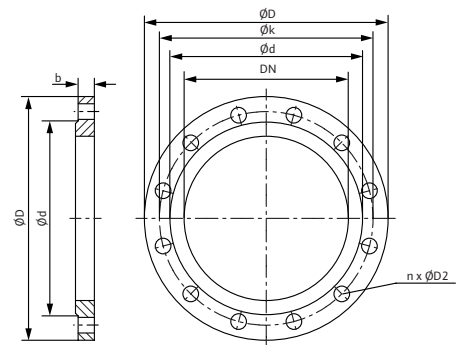

Submittal Data Sheet

Wilo SCP – Horizontal Split Case Pumps



SCP 12 x 10 x 27½ DV

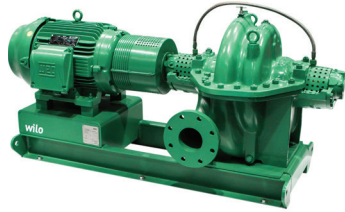

Project:	
Engineer:	
Contractor:	
Submitted By:	Date:
Approved By:	Date:

Tag #	Model #	Flow (USGPM)	Head (Feet)	HP	Enclosure TEFC/ODP	Frame	Cycle	Phase	Voltage	RPM
	SCP 12 x 10 x 27½ DV						60 Hz	3		

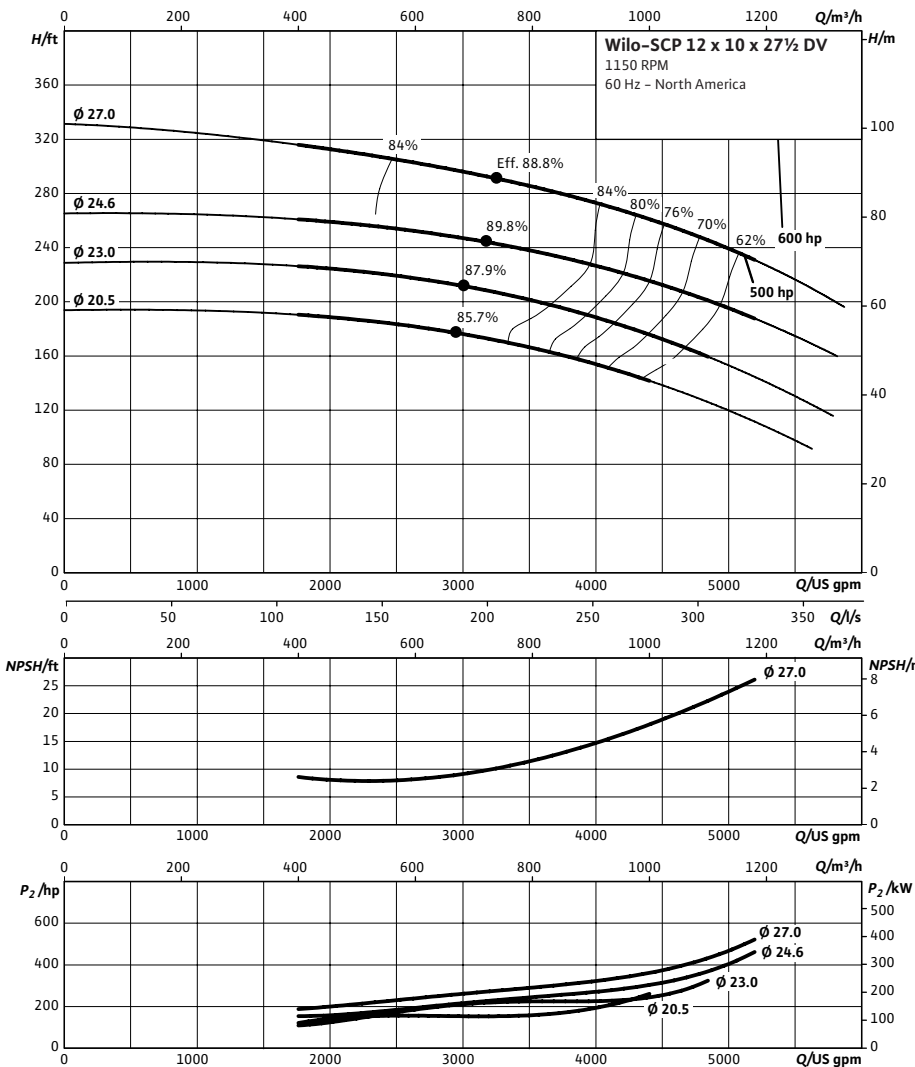

Technical Data

Approved Fluids
 Heating Water
 Cooling and cold water
 Water-Glycol mixtures (for 20–40% glycol and fluid temp ≤ 104°F [40°C])

Fluid Temperature
 Mechanical Seal 18°F to 250°F (–8°C to 120°C)
 Stuffing Box Packing 18°F to 220°F (–8°C to 105°C)

Materials of Construction

<input type="checkbox"/> Pump Housing	A48 Class 35
<input type="checkbox"/> Pump Housing (Optional)	Ni-resist BS 3468 Gr 2 / BS 2789 500.1
<input type="checkbox"/> Impeller	BS 84 C83 600
<input type="checkbox"/> Impeller (optional)	A48 Class 35 / BS 84 C83 600
<input type="checkbox"/> Stationary Wear Rings	BS 84 C93 700
<input type="checkbox"/> Pump Shaft	A276 type 410
<input type="checkbox"/> Pump Shaft (optional)	BS 970 316 S16
<input type="checkbox"/> Mechanical Seal	Carbon/silicon carbide/EPDM (E1)
<input type="checkbox"/> Other Mechanical Seals	Avail. on request
<input type="checkbox"/> Additional Spacer Coupling	Avail. on request
<input type="checkbox"/> Other:	

Approval Stamp

Dimensional Drawing

Single Stage Pump

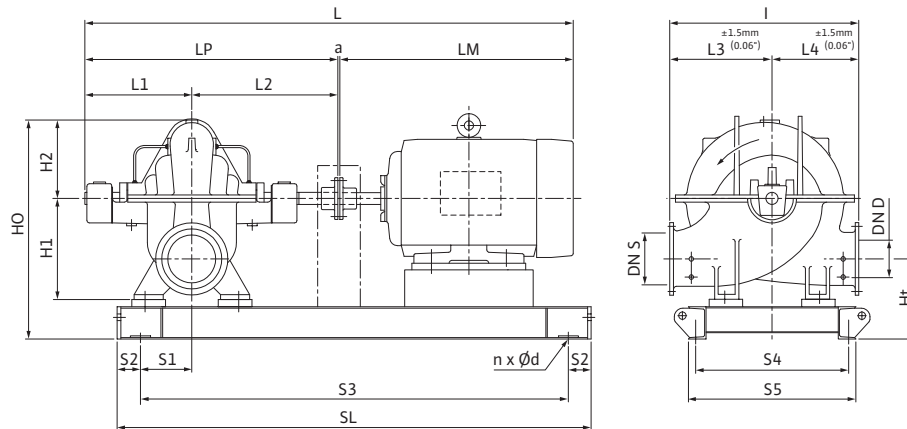

SCP 12 x 10 x 27½ DV

Dimensions - Inches (mm)

Frame	a	L	I	L1	L2	L3	L4	LM	LP	H1	H2	HO	Ht	n	Ød	S1	S2	S3	S4	S5	SL	P5	P6
*	.19 (5)	*	47.00 (1194)	25.31 (643)	30.13 (765)	25.00 (635)	22.00 (559)	*	55.44 (1408)	24.50 (622)	18.75 (476)	50.19 (1275)	15.44 (392)	*	*	9.56 (243)	4.00 (102)	*	*	*	*	-	-

* CONSULT FACTORY FOR MOTOR AND DIMENSIONS

Flange Dimensions – Suction Side

Dimensions - Inches (mm)

DN S #125	ØD	Ød	Øk	b	n	D2
12	19 (483)	15.00 (381)	17.00 (432)	1.25 (32)	12	1.00 (25)

Flange Dimensions – Discharge Side

Dimensions - Inches (mm)

DND 125#	ØD	Ød	Øk	b	n	D2
10	16.00 (406)	12.75 (324)	14.25 (362)	1.81 (30.16)	12	1.00 (25)

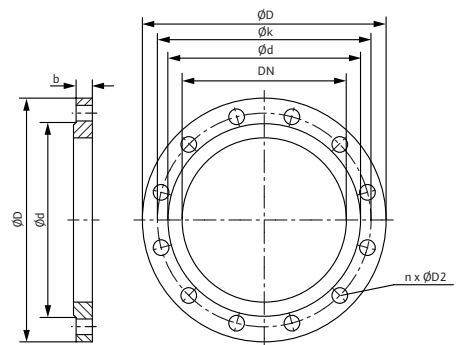

Submittal Data Sheet

Wilo SCP – Horizontal Split Case Pumps



SCP 12 x 10 x 29½ DV

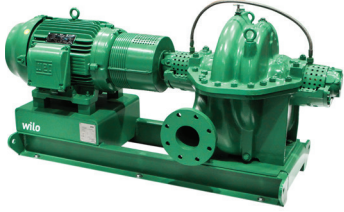

Project:	
Engineer:	
Contractor:	
Submitted By:	Date:
Approved By:	Date:

Tag #	Model #	Flow (USGPM)	Head (Feet)	HP	Enclosure TEFC/ODP	Frame	Cycle	Phase	Voltage	RPM
	SCP 12 x 10 x 29½ DV						60 Hz	3		

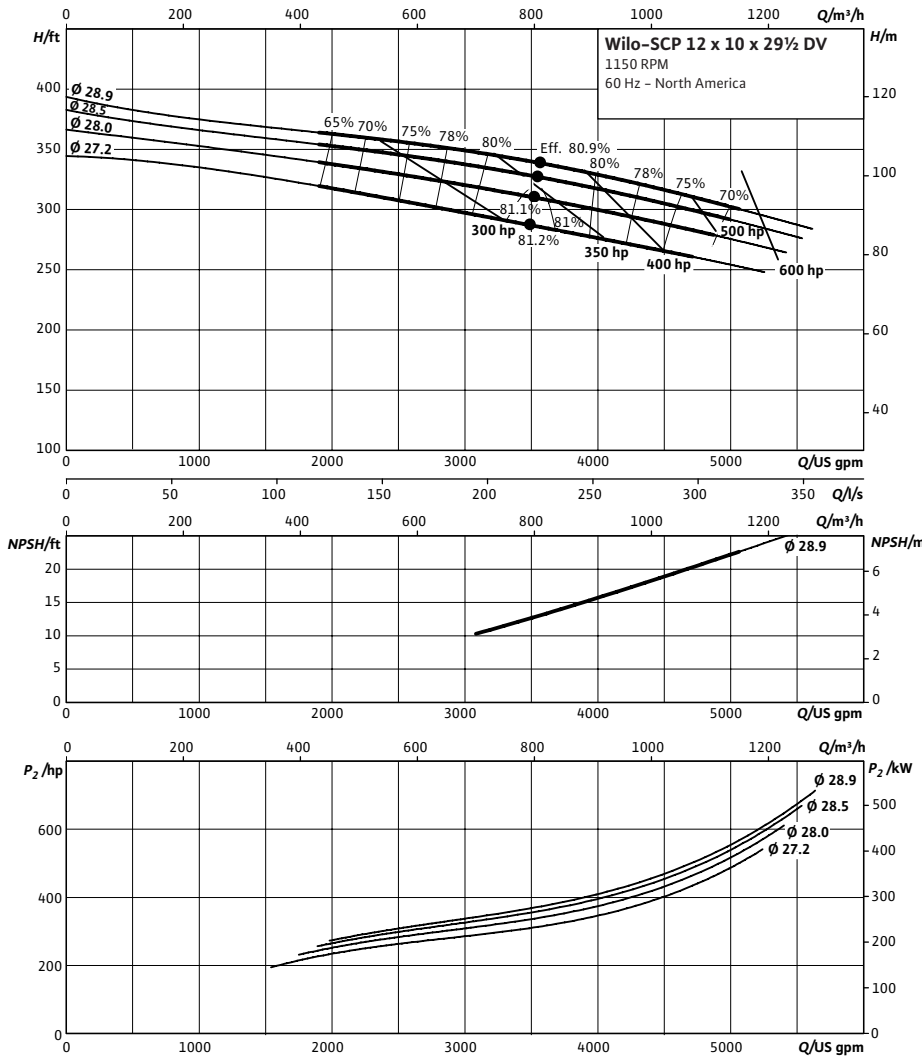

Technical Data

Approved Fluids

Heating Water
Cooling and cold water

Water-Glycol mixtures (for 20-40% glycol and fluid temp ≤ 104°F [40°C])

Fluid Temperature

Mechanical Seal 18°F to 250°F (-8°C to 120°C)
Stuffing Box Packing 18°F to 220°F (-8°C to 105°C)

Materials of Construction

<input type="checkbox"/>	Pump Housing	A48 Class 35
<input type="checkbox"/>	Pump Housing (Optional)	Ni-resist BS 3468 Gr 2 / BS 2789 500.1
<input type="checkbox"/>	Impeller	BS 84 C83 600
<input type="checkbox"/>	Impeller (optional)	A48 Class 35 / BS 84 C83 600
<input type="checkbox"/>	Stationary Wear Rings	BS 84 C93 700
<input type="checkbox"/>	Pump Shaft	A276 type 410
<input type="checkbox"/>	Pump Shaft (optional)	BS 970 316 S16
<input type="checkbox"/>	Mechanical Seal	Carbon/silicon carbide/EPDM (E1)
<input type="checkbox"/>	Other Mechanical Seals	Avail. on request
<input type="checkbox"/>	Additional Spacer Coupling	Avail. on request
<input type="checkbox"/>	Other:	

Approval Stamp

Dimensional Drawing

Single Stage Pump

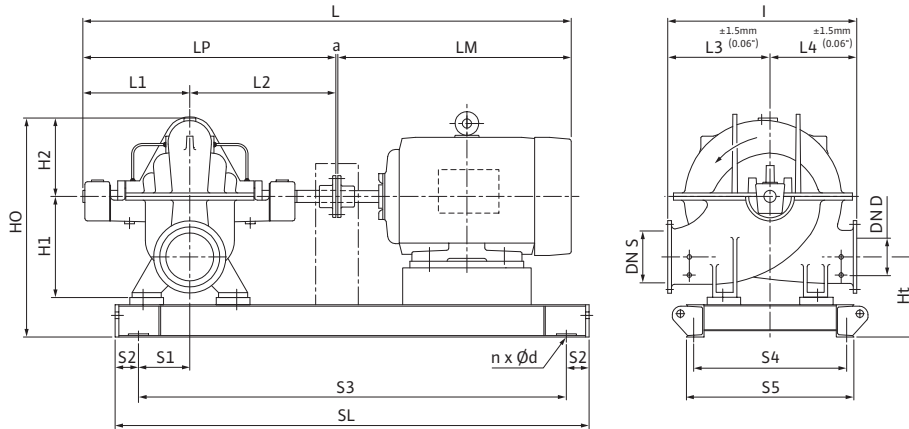

SCP 12 x 10 x 29½ DV

Dimensions - Inches (mm)

Frame	a	L	I	L1	L2	L3	L4	LM	LP	H1	H2	HO	Ht	n	Ød	S1	S2	S3	S4	S5	SL	P5	P6
*	.19 (5)	*	47.00 (1194)	25.31 (643)	30.13 (765)	25.00 (635)	22.00 (559)	*	55.44 (1408)	24.50 (622)	18.75 (476)	50.19 (1275)	15.44 (392)	*	*	9.56 (243)	4.00 (102)	*	*	*	*	-	-

* CONSULT FACTORY FOR MOTOR AND DIMENSIONS

Flange Dimensions – Suction Side

Dimensions - Inches (mm)

DN S #125	ØD	Ød	Øk	b	n	D2
12	19 (483)	15.00 (381)	17.00 (432)	1.25 (32)	12	1.00 (25)

Flange Dimensions – Discharge Side

Dimensions - Inches (mm)

DN D 125#	ØD	Ød	Øk	b	n	D2
10	16.00 (406)	12.75 (324)	14.25 (362)	1.81 (30.16)	12	1.00 (25)

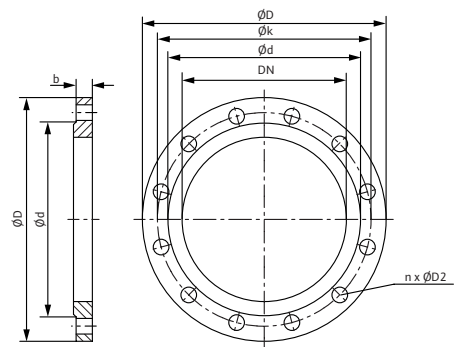

Submittal Data Sheet

Wilco SCP - Horizontal Split Case Pumps



SCP 14 x 12 x 15 HA

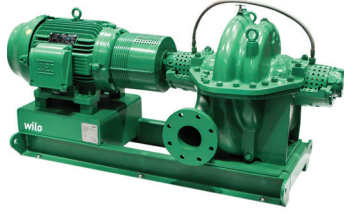

Project:	
Engineer:	
Contractor:	
Submitted By:	Date:
Approved By:	Date:

Tag #	Model #	Flow (USGPM)	Head (Feet)	HP	Enclosure TEFC/ODP	Frame	Cycle	Phase	Voltage	RPM
	SCP 14 x 12 x 15 HA						60 Hz	3		

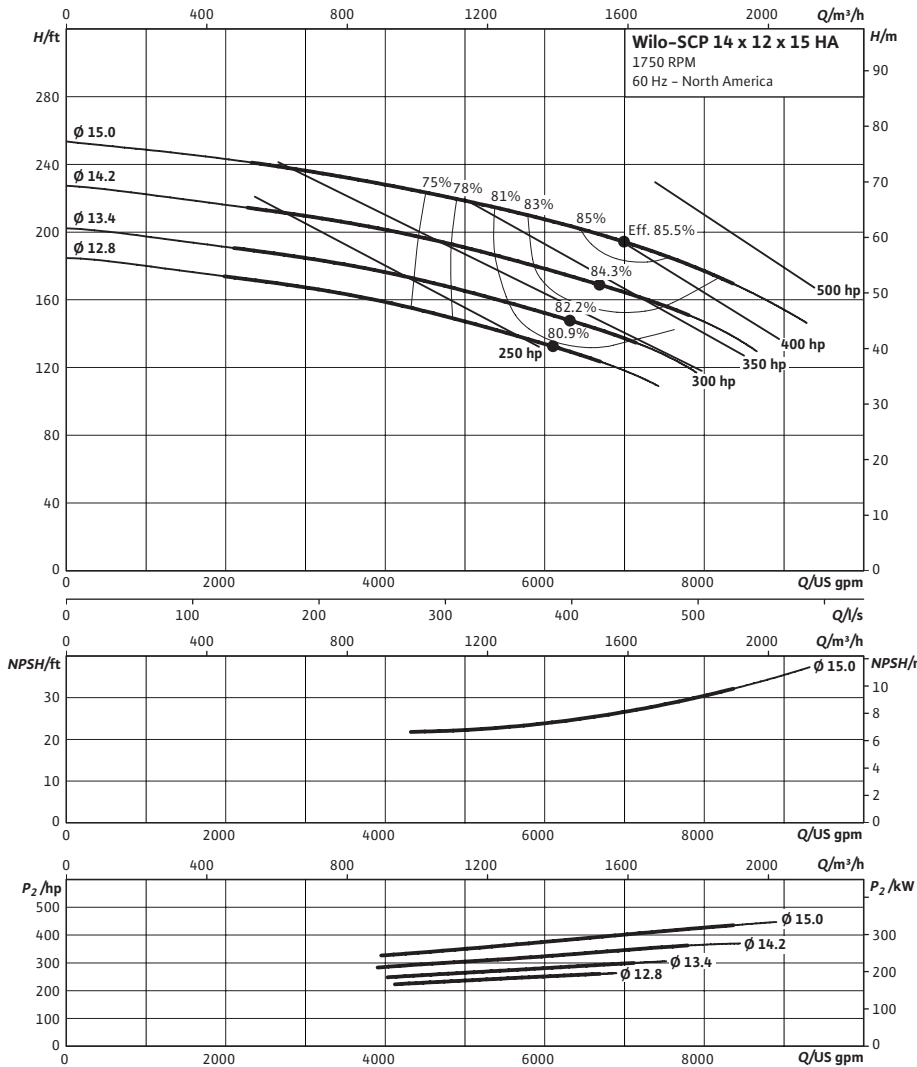

Technical Data

Approved Fluids

- Heating Water
- Cooling and cold water
- Water-Glycol mixtures (for 20-40% glycol and fluid temp ≤ 104°F [40°C])

Fluid Temperature

- Mechanical Seal: 18°F to 250°F (-8°C to 120°C)
- Stuffing Box Packing: 18°F to 220°F (-8°C to 105°C)

Materials of Construction

<input type="checkbox"/> Pump Housing	A48 Class 35
<input type="checkbox"/> Pump Housing (Optional)	Ni-resist BS 3468 Gr 2 / BS 2789 500.1
<input type="checkbox"/> Impeller	BS 84 C83 600
<input type="checkbox"/> Impeller (optional)	A48 Class 35 / BS 84 C83 600
<input type="checkbox"/> Stationary Wear Rings	BS 84 C93 700
<input type="checkbox"/> Pump Shaft	A276 type 410
<input type="checkbox"/> Pump Shaft (optional)	BS 970 316 S16
<input type="checkbox"/> Mechanical Seal	Carbon/silicon carbide/EPDM (E1)
<input type="checkbox"/> Other Mechanical Seals	Avail. on request
<input type="checkbox"/> Additional Spacer Coupling	Avail. on request
<input type="checkbox"/> Other:	

Approval Stamp

Dimensional Drawing

Single Stage Pump

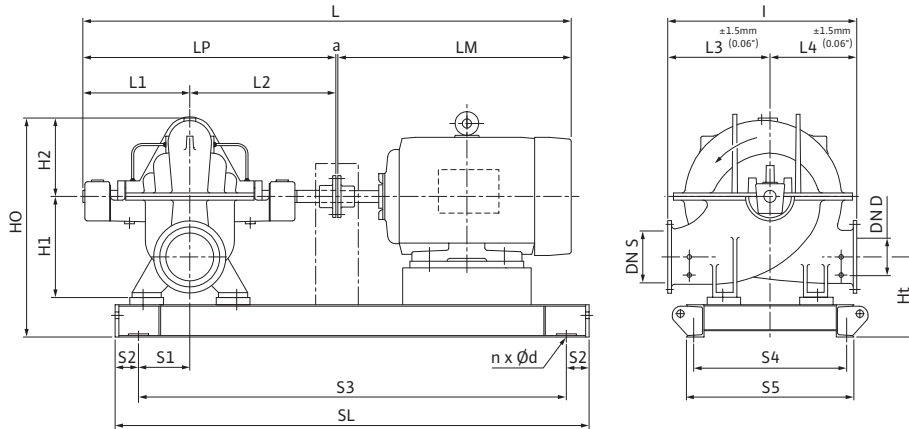

SCP 14 x 12 x 15 HA

Dimensions - Inches (mm)

Frame	a	L	I	L1	L2	L3	L4	LM	LP	H1	H2	HO	Ht	n	Ød	S1	S2	S3	S4	S5	SL	P5	P6
445T / 250 hp	.19 (5)	92.69 (2354)	37.38 (949)	20.69 (526)	24.13 (613)	22.00 (559)	15.38 (391)	47.75 (1213)	44.75 (1137)	21.50 (546)	14.75 (375)	42.13 (1070)	14.81 (376)	4	.91 (23)	8.19 (208)	4.00 (102)	65.50 (1664)	21.56 (548)	23.88 (607)	73.50 (1867)	-	-
445T / 300 hp	.19 (5)	98.38 (2499)	37.38 (949)	20.69 (526)	24.13 (613)	22.00 (559)	15.38 (391)	53.38 (1356)	44.75 (1137)	21.50 (546)	14.75 (375)	42.13 (1070)	14.81 (376)	4	.91 (23)	8.19 (208)	4.00 (102)	65.50 (1664)	21.56 (548)	23.88 (607)	73.50 (1867)	-	-
449T / 350 hp	.19 (5)	98.38 (2499)	37.38 (949)	20.69 (526)	24.13 (613)	22.00 (559)	15.38 (391)	53.38 (1356)	44.75 (1137)	21.50 (546)	14.75 (375)	42.13 (1070)	14.81 (376)	4	.91 (23)	8.19 (208)	4.00 (102)	73.75 (1873)	21.56 (548)	23.38 (594)	81.75 (2076)	-	-
449T / 400 hp	.19 (5)	98.38 (2499)	37.38 (949)	20.69 (526)	24.13 (613)	22.00 (559)	15.38 (391)	53.38 (1356)	44.75 (1137)	21.50 (546)	14.75 (375)	42.13 (1070)	14.81 (376)	4	.91 (23)	8.19 (208)	4.00 (102)	73.75 (1873)	21.56 (548)	23.38 (594)	81.75 (2076)	-	-

Flange Dimensions - Suction Side

Dimensions - Inches (mm)

DN S #125	ØD	Ød	Øk	b	n	D2
14	21.00 (533)	16.25 (413)	18.75 (476)	1.38 (35)	12	1.13 (29)

Flange Dimensions - Discharge Side

Dimensions - Inches (mm)

DN D 125#	ØD	Ød	Øk	b	n	D2
12	19 (483)	15.00 (381)	17.00 (432)	1.25 (32)	12	1.00 (25)

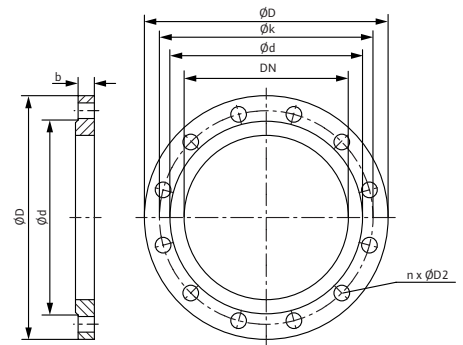

Submittal Data Sheet

Wilo SCP – Horizontal Split Case Pumps



SCP 14 x 12 x 19 HA

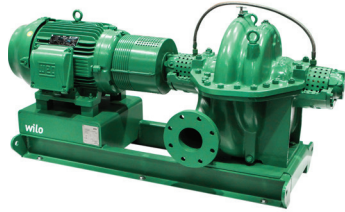

Project:	
Engineer:	
Contractor:	
Submitted By:	Date:
Approved By:	Date:

Tag #	Model #	Flow (USGPM)	Head (Feet)	HP	Enclosure TEFC/ODP	Frame	Cycle	Phase	Voltage	RPM
	SCP 14 x 12 x 19 HA						60 Hz	3		

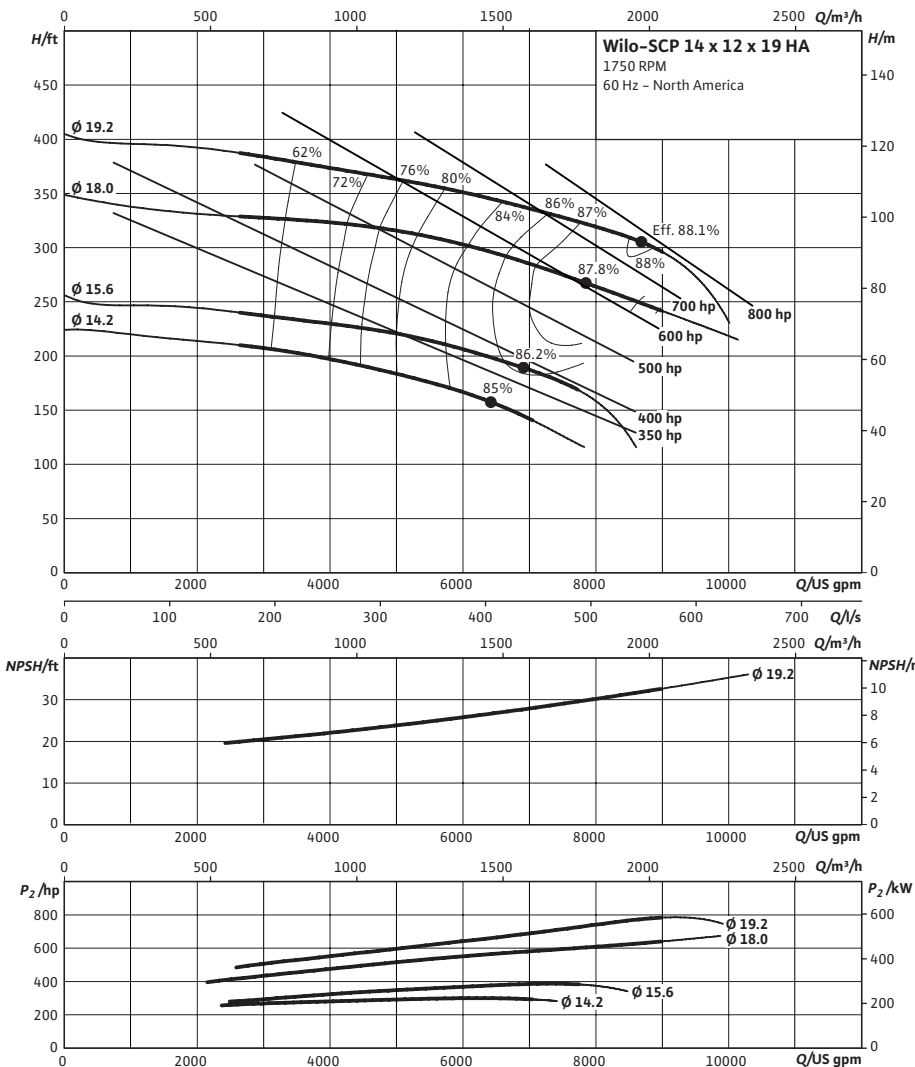

Technical Data

Approved Fluids	
Heating Water	
Cooling and cold water	
Water-Glycol mixtures (for 20–40% glycol and fluid temp ≤ 104°F [40°C])	

Fluid Temperature	
Mechanical Seal	18°F to 250°F (-8°C to 120°C)
Stuffing Box Packing	18°F to 220°F (-8°C to 105°C)

Materials of Construction

<input type="checkbox"/> Pump Housing	A48 Class 35
<input type="checkbox"/> Pump Housing (Optional)	Ni-resist BS 3468 Gr 2 / BS 2789 500.1
<input type="checkbox"/> Impeller	BS 84 C83 600
<input type="checkbox"/> Impeller (optional)	A48 Class 35 / BS 84 C83 600
<input type="checkbox"/> Stationary Wear Rings	BS 84 C93 700
<input type="checkbox"/> Pump Shaft	A276 type 410
<input type="checkbox"/> Pump Shaft (optional)	BS 970 316 S16
<input type="checkbox"/> Mechanical Seal	Carbon/silicon carbide/EPDM (E1)
<input type="checkbox"/> Other Mechanical Seals	Avail. on request
<input type="checkbox"/> Additional Spacer Coupling	Avail. on request
<input type="checkbox"/> Other:	

Approval Stamp

Dimensional Drawing

Single Stage Pump

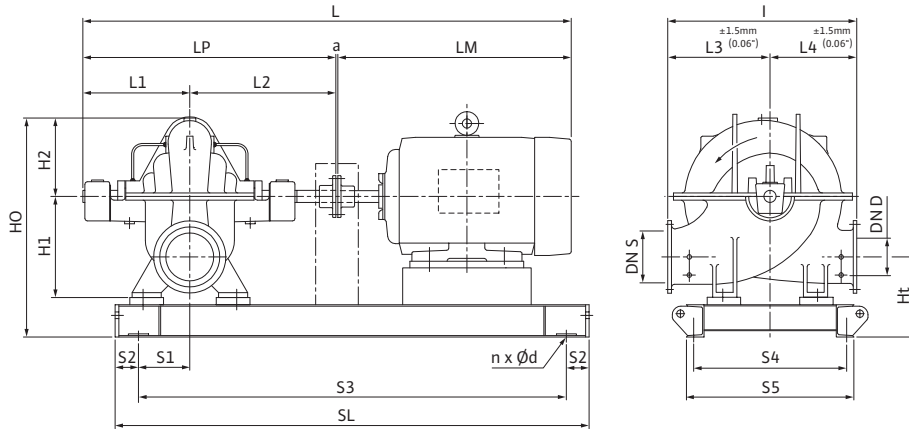

SCP 14 x 12 x 19 HA

Dimensions - Inches (mm)

Frame	a	L	I	L1	L2	L3	L4	LM	LP	H1	H2	HO	Ht	n	Ød	S1	S2	S3	S4	S5	SL	P5	P6
449T/ 350 hp	.19 (5)	104.25 (2678)	42.00 (1067)	23.38 (594)	27.31 (694)	23.00 (584)	19.00 (483)	53.38 (1356)	50.69 (1284)	23.25 (591)	15.94 (405)	46.13 (1172)	16.69 (424)	4	.91 (23)	10.75 (273)	4.00 (102)	79.50 (2019)	23.63 (600)	26.38 (670)	87.50 (2223)	-	-
449T/ 400 hp	.19 (5)	104.25 (2678)	42.00 (1067)	23.38 (594)	27.31 (694)	23.00 (584)	19.00 (483)	53.38 (1356)	50.69 (1284)	23.25 (591)	15.94 (405)	46.13 (1172)	16.69 (424)	4	.91 (23)	10.75 (273)	4.00 (102)	79.50 (2019)	23.63 (600)	26.38 (670)	87.50 (2223)	-	-

Flange Dimensions - Suction Side

Dimensions - Inches (mm)

DN S #125	ØD	Ød	Øk	b	n	D2
14	21.00 (533)	16.25 (413)	18.75 (476)	1.38 (35)	12	1.13 (29)

Flange Dimensions - Discharge Side

Dimensions - Inches (mm)

DND 125#	ØD	Ød	Øk	b	n	D2
12	19 (483)	15.00 (381)	17.00 (432)	1.25 (32)	12	1.00 (25)

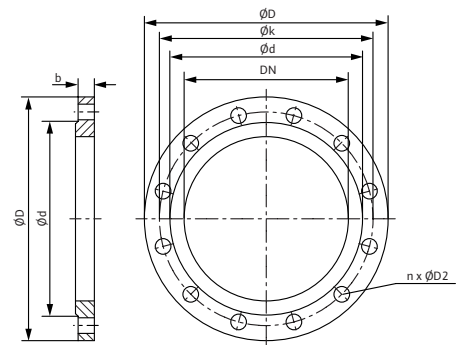

Submittal Data Sheet

Wilo SCP – Horizontal Split Case Pumps



SCP 14 x 12 x 22 HA

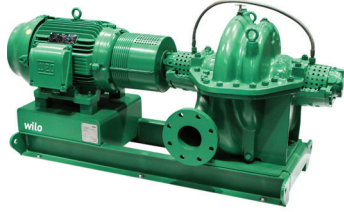

Project:	
Engineer:	
Contractor:	
Submitted By:	Date:
Approved By:	Date:

Tag #	Model #	Flow (USGPM)	Head (Feet)	HP	Enclosure TEFC/ODP	Frame	Cycle	Phase	Voltage	RPM
	SCP 14 x 12 x 22 HA						60 Hz	3		

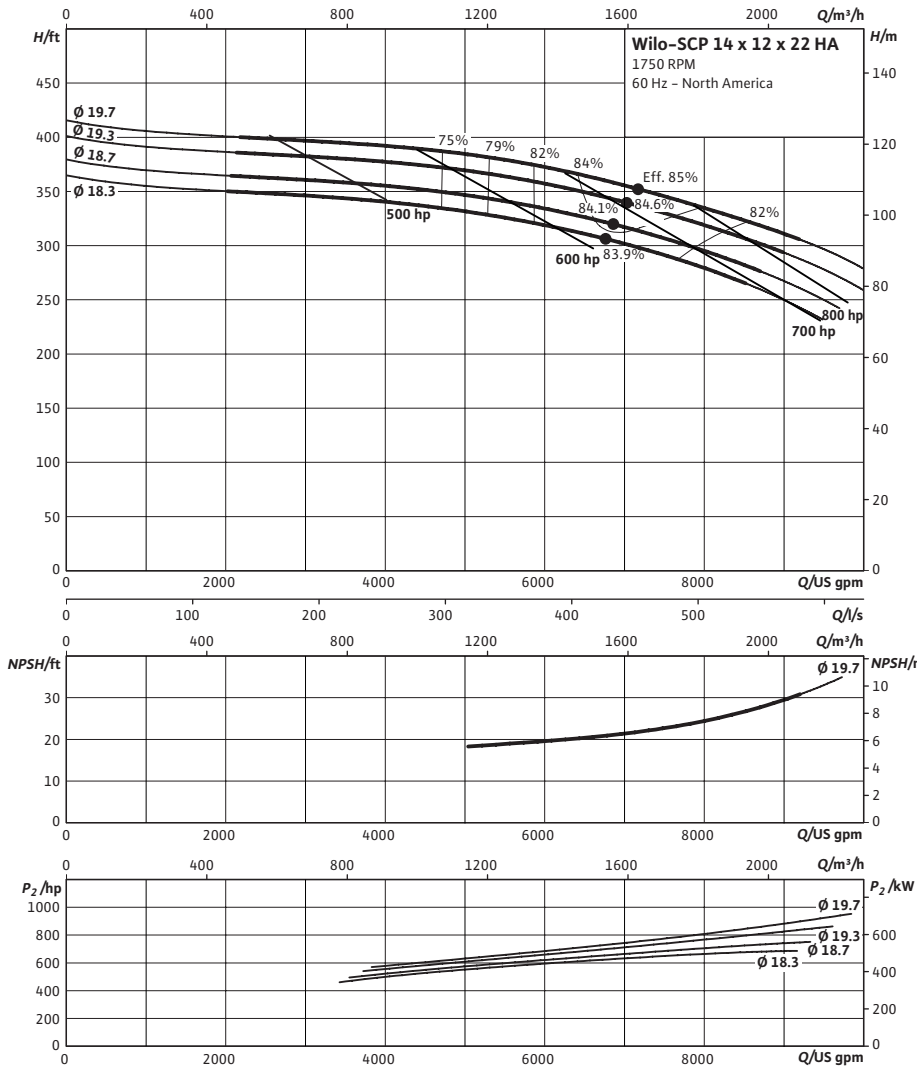

Technical Data

Approved Fluids

Heating Water
Cooling and cold water

Water-Glycol mixtures (for 20-40% glycol and fluid temp ≤ 104°F [40°C])

Fluid Temperature

Mechanical Seal 18°F to 250°F (-8°C to 120°C)
Stuffing Box Packing 18°F to 220°F (-8°C to 105°C)

Materials of Construction

<input type="checkbox"/>	Pump Housing	A48 Class 35
<input type="checkbox"/>	Pump Housing (Optional)	Ni-resist BS 3468 Gr 2 / BS 2789 500.1
<input type="checkbox"/>	Impeller	BS 84 C83 600
<input type="checkbox"/>	Impeller (optional)	A48 Class 35 / BS 84 C83 600
<input type="checkbox"/>	Stationary Wear Rings	BS 84 C93 700
<input type="checkbox"/>	Pump Shaft	A276 type 410
<input type="checkbox"/>	Pump Shaft (optional)	BS 970 316 S16
<input type="checkbox"/>	Mechanical Seal	Carbon/silicon carbide/EPDM (E1)
<input type="checkbox"/>	Other Mechanical Seals	Avail. on request
<input type="checkbox"/>	Additional Spacer Coupling	Avail. on request
<input type="checkbox"/>	Other:	

Approval Stamp

Dimensional Drawing

Single Stage Pump

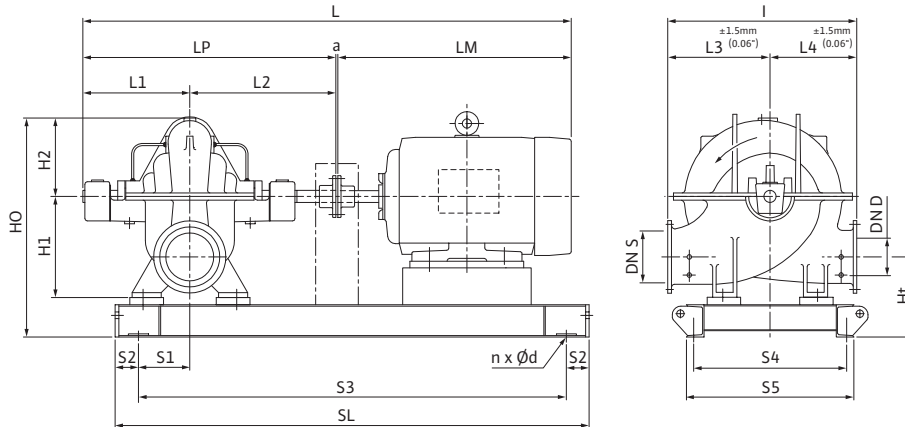

SCP 14 x 12 x 22 HA

Dimensions - Inches (mm)																							
Frame	a	L	I	L1	L2	L3	L4	LM	LP	H1	H2	HO	Ht	n	Ød	S1	S2	S3	S4	S5	SL	P5	P6
*	.19 (5)	*	45.75 (1162)	23.38 (594)	27.25 (692)	24.75 (629)	21.00 (533)	*	50.69 (1288)	23.25 (591)	17.31 (440)	47.50 (1207)	15.31 (309)	*	*	10.75 (273)	4.00 (102)	*	*	*	*	-	-

* CONSULT FACTORY FOR MOTOR AND DIMENSIONS

Flange Dimensions - Suction Side

Dimensions - Inches (mm)						
DN S #125	ØD	Ød	Øk	b	n	D2
14	21.00 (533)	16.25 (413)	18.75 (476)	1.38 (35)	12	1.13 (29)

Flange Dimensions - Discharge Side

Dimensions - Inches (mm)						
DND 125#	ØD	Ød	Øk	b	n	D2
12	19 (483)	15.00 (381)	17.00 (432)	1.25 (32)	12	1.00 (25)

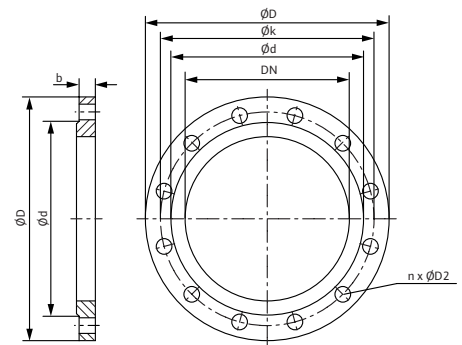

Submittal Data Sheet

Wilco SCP – Horizontal Split Case Pumps



SCP 14 x 12 x 26 DV

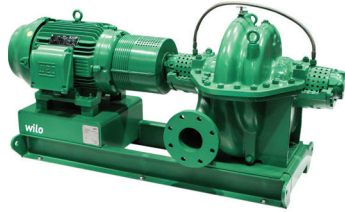

Project:	
Engineer:	
Contractor:	
Submitted By:	Date:
Approved By:	Date:

Tag #	Model #	Flow (USGPM)	Head (Feet)	HP	Enclosure TEFC/ODP	Frame	Cycle	Phase	Voltage	RPM
	SCP 14 x 12 x 26 DV						60 Hz	3		

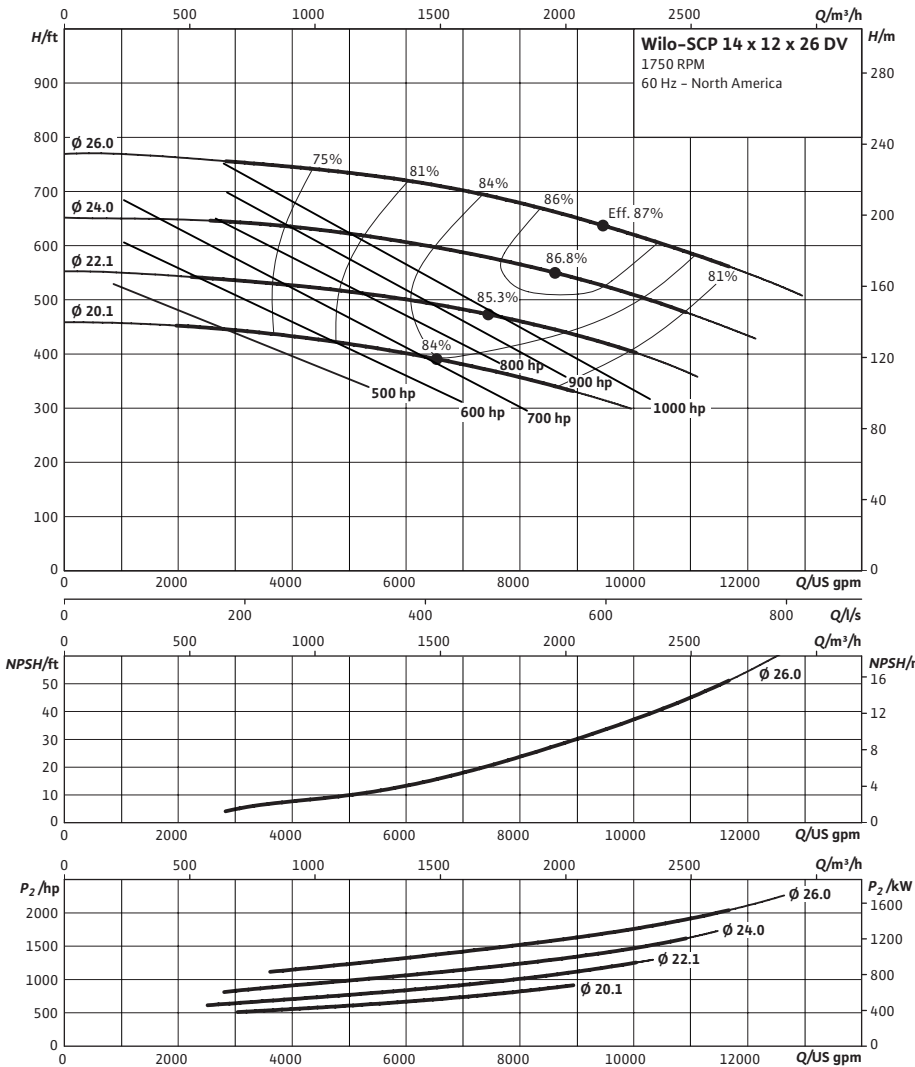

Technical Data

Approved Fluids

Heating Water
Cooling and cold water

Water-Glycol mixtures (for 20-40% glycol and fluid temp ≤ 104°F [40°C])

Fluid Temperature

Mechanical Seal 18°F to 250°F (-8°C to 120°C)
Stuffing Box Packing 18°F to 220°F (-8°C to 105°C)

Materials of Construction

<input type="checkbox"/>	Pump Housing	A48 Class 35
<input type="checkbox"/>	Pump Housing (Optional)	Ni-resist BS 3468 Gr 2 / BS 2789 500.1
<input type="checkbox"/>	Impeller	BS 84 C83 600
<input type="checkbox"/>	Impeller (optional)	A48 Class 35 / BS 84 C83 600
<input type="checkbox"/>	Stationary Wear Rings	BS 84 C93 700
<input type="checkbox"/>	Pump Shaft	A276 type 410
<input type="checkbox"/>	Pump Shaft (optional)	BS 970 316 S16
<input type="checkbox"/>	Mechanical Seal	Carbon/silicon carbide/EPDM (E1)
<input type="checkbox"/>	Other Mechanical Seals	Avail. on request
<input type="checkbox"/>	Additional Spacer Coupling	Avail. on request
<input type="checkbox"/>	Other:	

Approval Stamp

Dimensional Drawing

Single Stage Pump

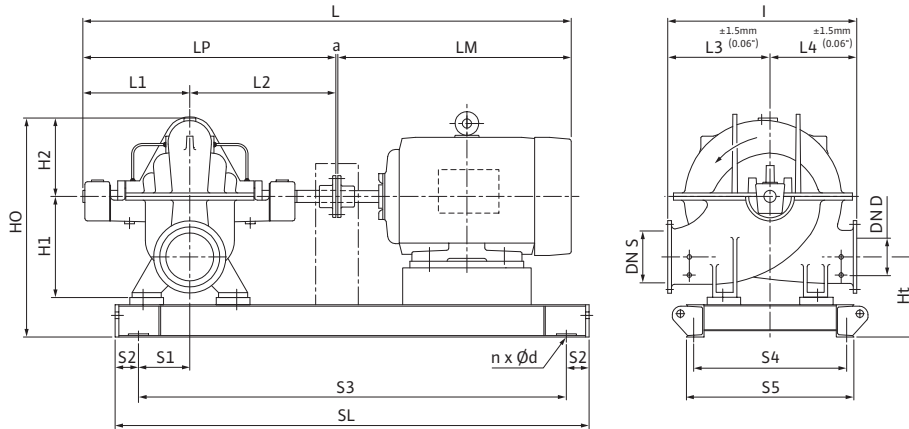

SCP 14 x 12 x 26 DV

Dimensions - Inches (mm)

Frame	a	L	I	L1	L2	L3	L4	LM	LP	H1	H2	HO	Ht	n	Ød	S1	S2	S3	S4	S5	SL	P5	P6
*	.19 (5)	*	50.00 (1270)	26.75 (680)	32.69 (830)	26.00 (660)	24.00 (610)	*	59.44 (1510)	28.54 (725)	18.31 (465)	53.81 (1367)	18.00 (457)	*	*	6.81 (173)	4.00 (102)	*	*	*	*	-	-

* CONSULT FACTORY FOR MOTOR AND DIMENSIONS

Flange Dimensions - Suction Side

Dimensions - Inches (mm)

DN S #125	ØD	Ød	Øk	b	n	D2
14	21.00 (533)	16.25 (413)	18.75 (476)	1.38 (35)	12	1.13 (29)

Flange Dimensions - Discharge Side

Dimensions - Inches (mm)

DND 125#	ØD	Ød	Øk	b	n	D2
12	19 (483)	15.00 (381)	17.00 (432)	1.25 (32)	12	1.00 (25)

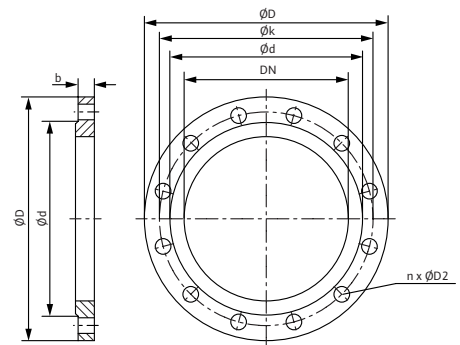

Submittal Data Sheet

Wilo SCP – Horizontal Split Case Pumps



SCP 16 x 12 x 15½ HA

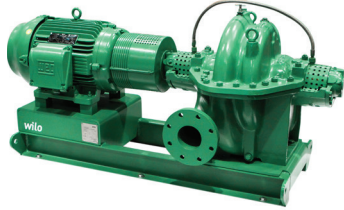

Project:	
Engineer:	
Contractor:	
Submitted By:	Date:
Approved By:	Date:

Tag #	Model #	Flow (USGPM)	Head (Feet)	HP	Enclosure TEFC/ODP	Frame	Cycle	Phase	Voltage	RPM
	SCP 16 x 12 x 15½ HA						60 Hz	3		

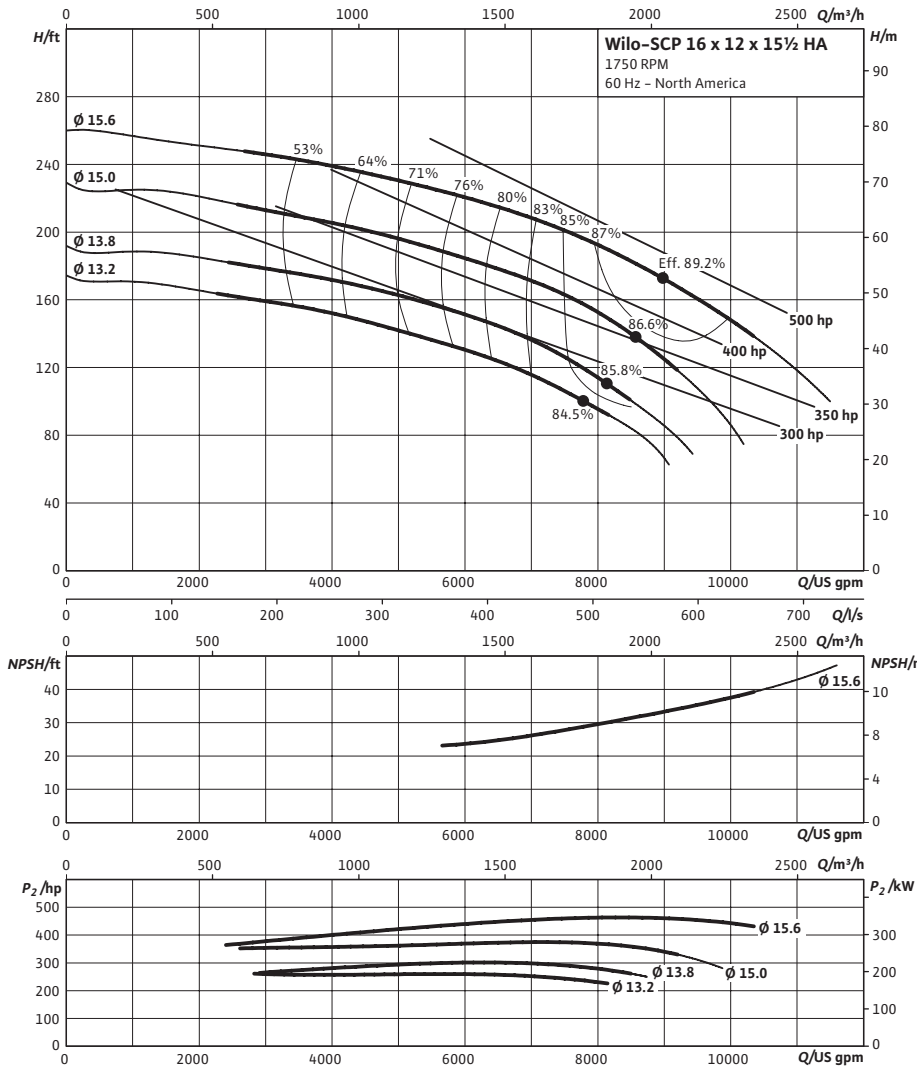

Technical Data

Approved Fluids

Heating Water
Cooling and cold water

Water-Glycol mixtures (for 20-40% glycol and fluid temp ≤ 104°F [40°C])

Fluid Temperature

Mechanical Seal: 18°F to 250°F (-8°C to 120°C)
Stuffing Box Packing: 18°F to 220°F (-8°C to 105°C)

Materials of Construction

<input type="checkbox"/>	Pump Housing	A48 Class 35
<input type="checkbox"/>	Pump Housing (Optional)	Ni-resist BS 3468 Gr 2 / BS 2789 500.1
<input type="checkbox"/>	Impeller	BS 84 C83 600
<input type="checkbox"/>	Impeller (optional)	A48 Class 35 / BS 84 C83 600
<input type="checkbox"/>	Stationary Wear Rings	BS 84 C93 700
<input type="checkbox"/>	Pump Shaft	A276 type 410
<input type="checkbox"/>	Pump Shaft (optional)	BS 970 316 S16
<input type="checkbox"/>	Mechanical Seal	Carbon/silicon carbide/EPDM (E1)
<input type="checkbox"/>	Other Mechanical Seals	Avail. on request
<input type="checkbox"/>	Additional Spacer Coupling	Avail. on request
<input type="checkbox"/>	Other:	

Approval Stamp

Dimensional Drawing

Single Stage Pump

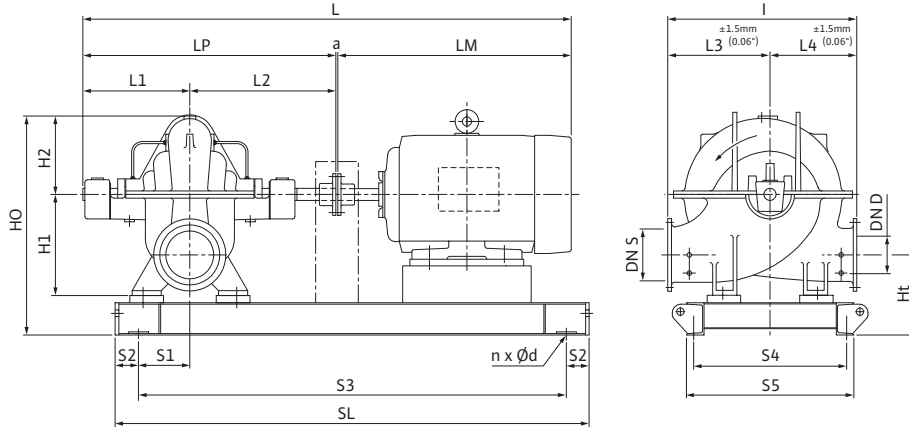

SCP 16 x 12 x 15½ HA

Dimensions - Inches (mm)

Frame	a	L	I	L1	L2	L3	L4	LM	LP	H1	H2	HO	Ht	n	Ød	S1	S2	S3	S4	S5	SL	P5	P6
449T / 300 hp	.19 (5)	101.75 (2584)	35.44 (900)	21.88 (556)	26.25 (667)	21.63 (549)	13.75 (349)	53.38 (1356)	48.19 (1224)	24.00 (610)	15.38 (391)	45.31 (1151)	16.19 (411)	4	.91 (23)	9.19 (233)	4.00 (102)	68.69 (1745)	21.56 (548)	23.88 (607)	76.69 (1948)	-	-
449T / 350 hp	.19 (5)	101.75 (2584)	35.44 (900)	21.88 (556)	26.25 (667)	21.63 (549)	13.75 (349)	53.38 (1356)	48.19 (1224)	24.00 (610)	15.38 (391)	45.31 (1151)	16.19 (411)	4	.91 (23)	10.75 (273)	4.00 (102)	76.94 (1954)	21.56 (548)	23.88 (607)	84.94 (2157)	-	-
449T / 400 hp	.19 (5)	101.75 (2584)	35.44 (900)	21.88 (556)	26.25 (667)	21.63 (549)	13.75 (349)	53.38 (1356)	48.19 (1224)	24.00 (610)	15.38 (391)	45.31 (1151)	16.19 (411)	4	.91 (23)	10.75 (273)	4.00 (102)	76.94 (1954)	21.56 (548)	23.88 (607)	84.94 (2157)	-	-

Flange Dimensions - Suction Side

Dimensions - Inches (mm)

DN S #125	ØD	Ød	Øk	b	n	D2
16	23.50 (597)	18.50 (570)	21.25 (540)	1.38 (37)	16	1.13 (29)

Flange Dimensions - Discharge Side

Dimensions - Inches (mm)

DN D 125#	ØD	Ød	Øk	b	n	D2
12	19 (483)	15.00 (381)	17.00 (432)	1.25 (32)	12	1.00 (25)

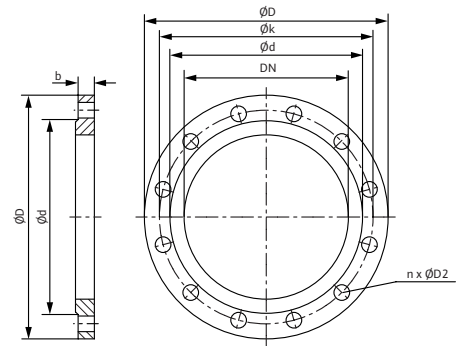

Submittal Data Sheet

Wilo SCP – Horizontal Split Case Pumps



SCP 18 x 14 x 19 HA

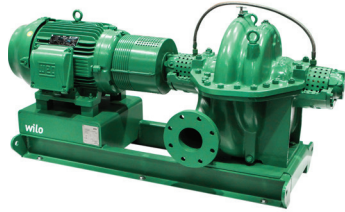

Project:	
Engineer:	
Contractor:	
Submitted By:	Date:
Approved By:	Date:

Tag #	Model #	Flow (USGPM)	Head (Feet)	HP	Enclosure TEFC/ODP	Frame	Cycle	Phase	Voltage	RPM
	SCP 18 x 14 x 19 HA						60 Hz	3		

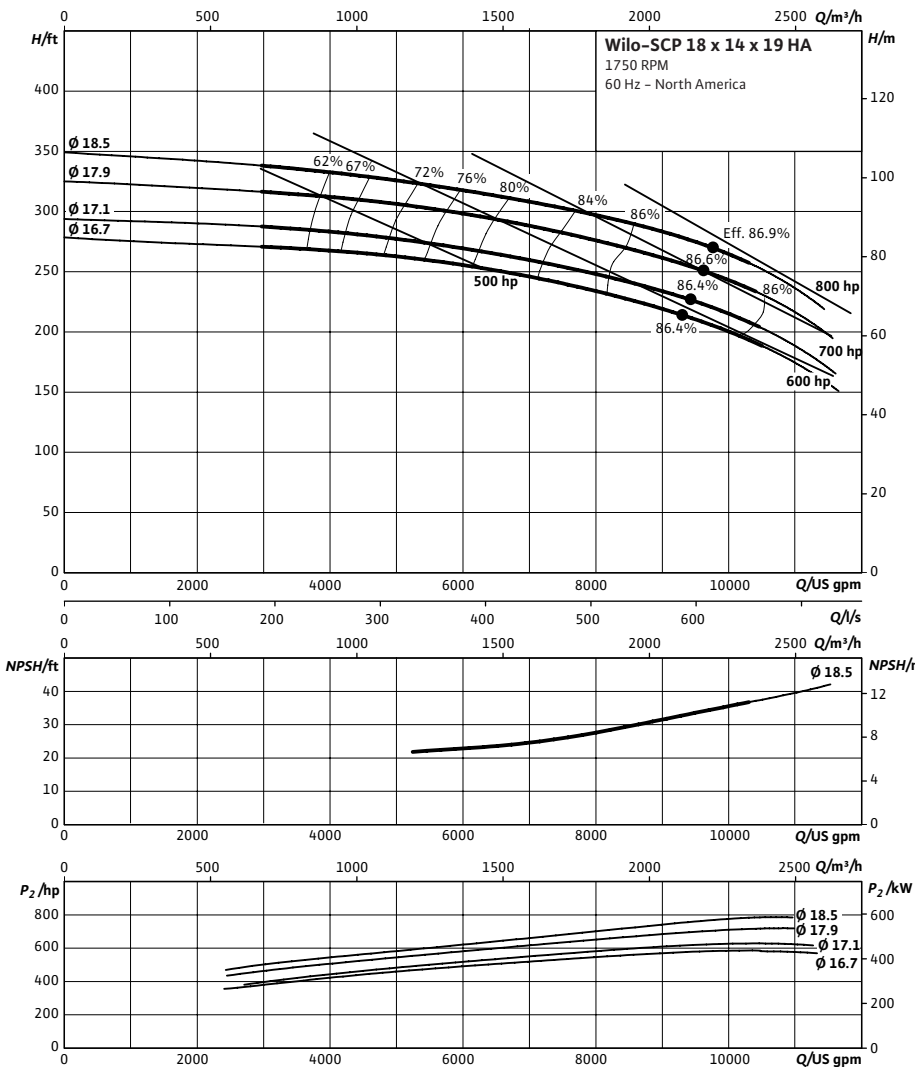

Technical Data

Approved Fluids

- Heating Water
- Cooling and cold water
- Water-Glycol mixtures (for 20–40% glycol and fluid temp ≤ 104°F [40°C])

Fluid Temperature

- Mechanical Seal: 18°F to 250°F (–8°C to 120°C)
- Stuffing Box Packing: 18°F to 220°F (–8°C to 105°C)

Materials of Construction

<input type="checkbox"/> Pump Housing	A48 Class 35
<input type="checkbox"/> Pump Housing (Optional)	Ni-resist BS 3468 Gr 2 / BS 2789 500.1
<input type="checkbox"/> Impeller	BS 84 C83 600
<input type="checkbox"/> Impeller (optional)	A48 Class 35 / BS 84 C83 600
<input type="checkbox"/> Stationary Wear Rings	BS 84 C93 700
<input type="checkbox"/> Pump Shaft	A276 type 410
<input type="checkbox"/> Pump Shaft (optional)	BS 970 316 S16
<input type="checkbox"/> Mechanical Seal	Carbon/silicon carbide/EPDM (E1)
<input type="checkbox"/> Other Mechanical Seals	Avail. on request
<input type="checkbox"/> Additional Spacer Coupling	Avail. on request
<input type="checkbox"/> Other:	

Approval Stamp

Dimensional Drawing

Single Stage Pump

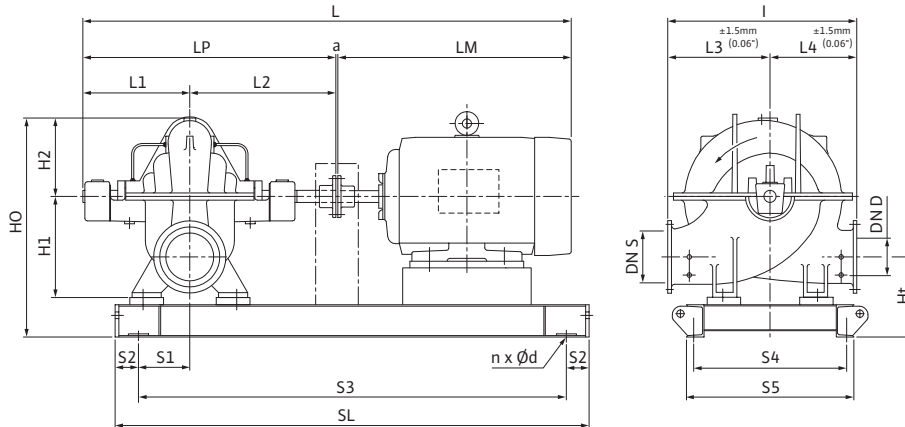

SCP 18 x 14 x 19 HA

Dimensions - Inches (mm)																							
Frame	a	L	I	L1	L2	L3	L4	LM	LP	H1	H2	HO	Ht	n	Ød	S1	S2	S3	S4	S5	SL	P5	P6
*	.19 (5)	*	45.44 (1154)	23.38 (594)	27.25 (692)	24.63 (625)	20.88 (530)	*	50.63 (1286)	26.00 (660)	16.75 (425)	49.63 (1261)	18.75 (476)	*	*	12.38 (314)	4.00 (102)	*	*	*	*	-	-

* CONSULT FACTORY FOR MOTOR AND DIMENSIONS

Flange Dimensions - Suction Side

Dimensions - Inches (mm)						
DN S #125	ØD	Ød	Øk	b	n	D2
18	25.00 (635)	21.00 (533)	23.75 (578)	1.56 (40)	16	1.25 (32)

Flange Dimensions - Discharge Side

Dimensions - Inches (mm)						
DN D 125#	ØD	Ød	Øk	b	n	D2
14	21.00 (533)	16.25 (513)	18.75 (476)	1.38 (35)	12	1.13 (29)

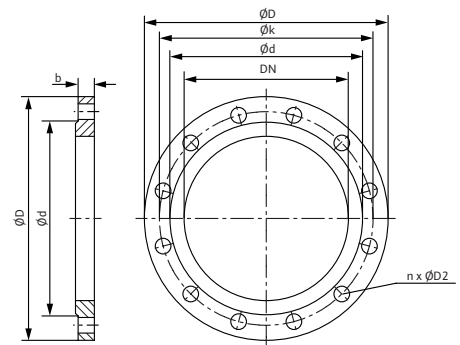

Submittal Data Sheet

Wilo SCP – Horizontal Split Case Pumps



SCP 18 x 14 x 19½ HA

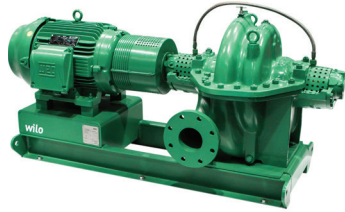

Project:	
Engineer:	
Contractor:	
Submitted By:	Date:
Approved By:	Date:

Tag #	Model #	Flow (USGPM)	Head (Feet)	HP	Enclosure TEFC/ODP	Frame	Cycle	Phase	Voltage	RPM
	SCP 18 x 14 x 19½ HA						60 Hz	3		

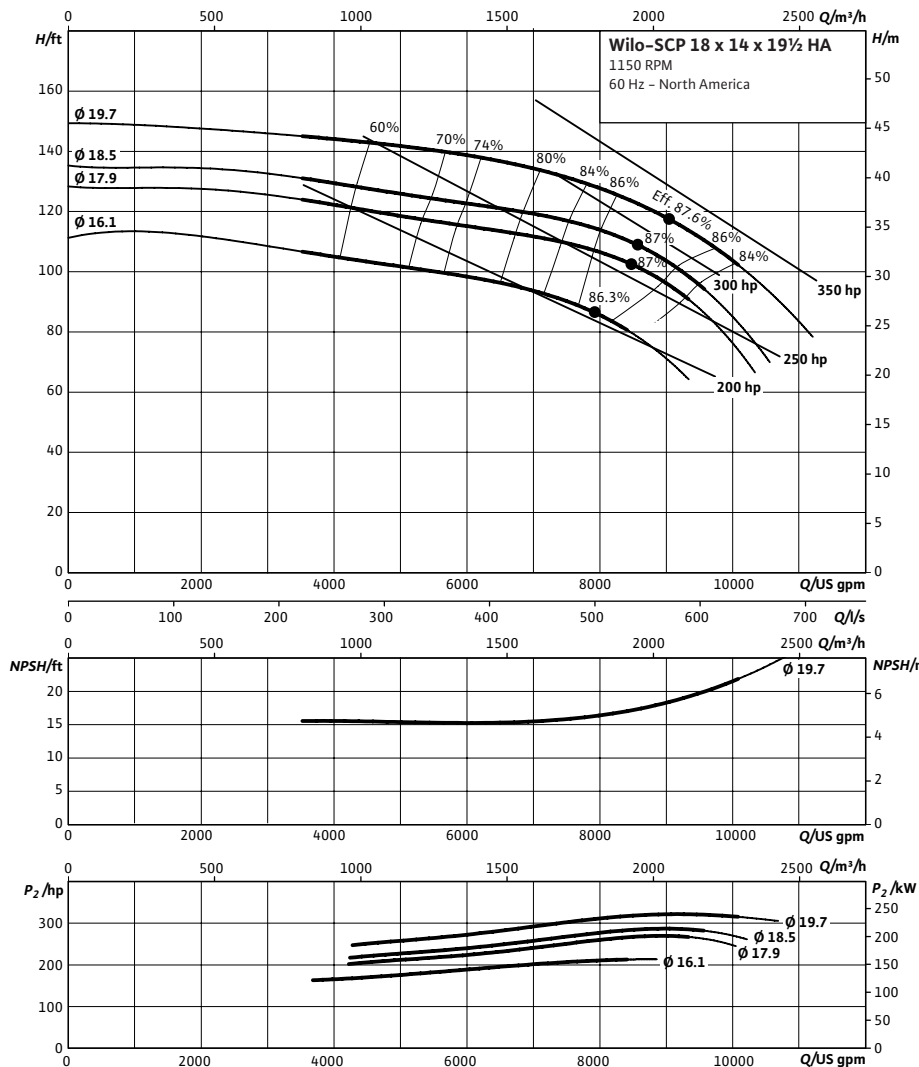

Technical Data

Approved Fluids

- Heating Water
- Cooling and cold water
- Water-Glycol mixtures (for 20–40% glycol and fluid temp ≤ 104°F [40°C])

Fluid Temperature

- Mechanical Seal: 18°F to 250°F (–8°C to 120°C)
- Stuffing Box Packing: 18°F to 220°F (–8°C to 105°C)

Materials of Construction

<input type="checkbox"/> Pump Housing	A48 Class 35
<input type="checkbox"/> Pump Housing (Optional)	Ni-resist BS 3468 Gr 2 / BS 2789 500.1
<input type="checkbox"/> Impeller	BS 84 C83 600
<input type="checkbox"/> Impeller (optional)	A48 Class 35 / BS 84 C83 600
<input type="checkbox"/> Stationary Wear Rings	BS 84 C93 700
<input type="checkbox"/> Pump Shaft	A276 type 410
<input type="checkbox"/> Pump Shaft (optional)	BS 970 316 S16
<input type="checkbox"/> Mechanical Seal	Carbon/silicon carbide/EPDM (E1)
<input type="checkbox"/> Other Mechanical Seals	Avail. on request
<input type="checkbox"/> Additional Spacer Coupling	Avail. on request
<input type="checkbox"/> Other:	

Approval Stamp

Dimensional Drawing

Single Stage Pump

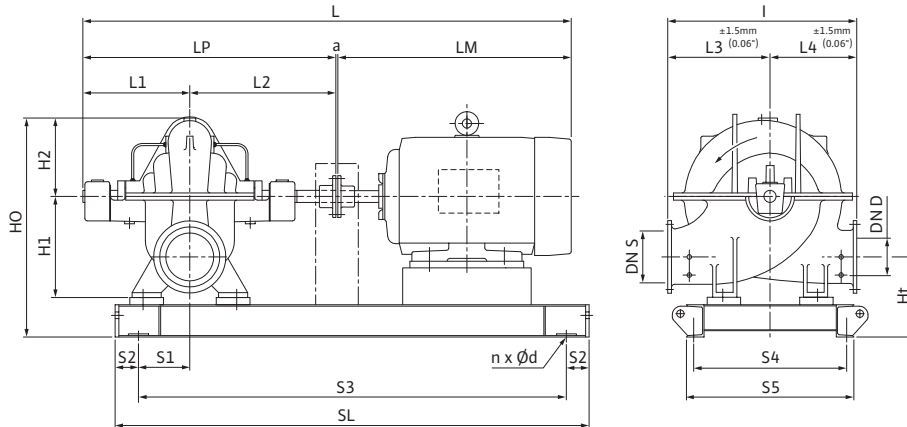

SCP 18 x 14 x 19½ HA

Dimensions – Inches (mm)

Frame	a	L	I	L1	L2	L3	L4	LM	LP	H1	H2	HO	Ht	n	Ød	S1	S2	S3	S4	S5	SL	P5	P6
445T	.50 (13)	107.06 (2719)	51.88 (1318)	24.56 (624)	28.56 (725)	30.25 (768)	21.63 (549)	53.38 (1356)	53.13 (1350)	27.00 (686)	20.50 (521)	54.44 (1383)	16.00 (406)	4	.91 (23)	13.94 (354)	4.00 (102)	87.94 (2234)	31.13 (791)	33.88 (861)	95.94 (2437)	-	-

Additional Motors Available – CONSULT FACTORY

Flange Dimensions – Suction Side

Dimensions – Inches (mm)

DN S #125	ØD	Ød	Øk	b	n	D2
18	25.00 (635)	21.00 (533)	23.75 (578)	1.56 (40)	16	1.25 (32)

Flange Dimensions – Discharge Side

Dimensions – Inches (mm)

DN D 125#	ØD	Ød	Øk	b	n	D2
14	21.00 (533)	16.25 (513)	18.75 (476)	1.38 (35)	12	1.13 (29)

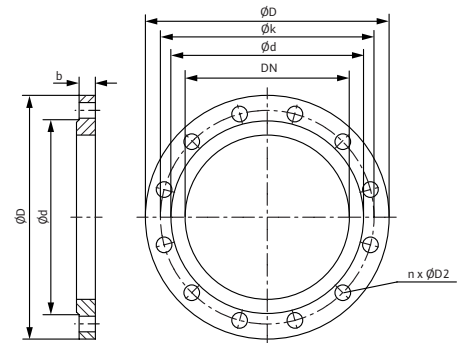

Submittal Data Sheet

Wilo SCP – Horizontal Split Case Pumps



SCP 18 x 16 x 28 HA

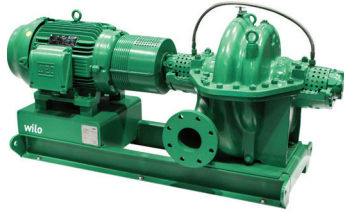

Project:	
Engineer:	
Contractor:	
Submitted By:	Date:
Approved By:	Date:

Tag #	Model #	Flow (USGPM)	Head (Feet)	HP	Enclosure TEFC/ODP	Frame	Cycle	Phase	Voltage	RPM
	SCP 18 x 16 x 28 HA						60 Hz	3		

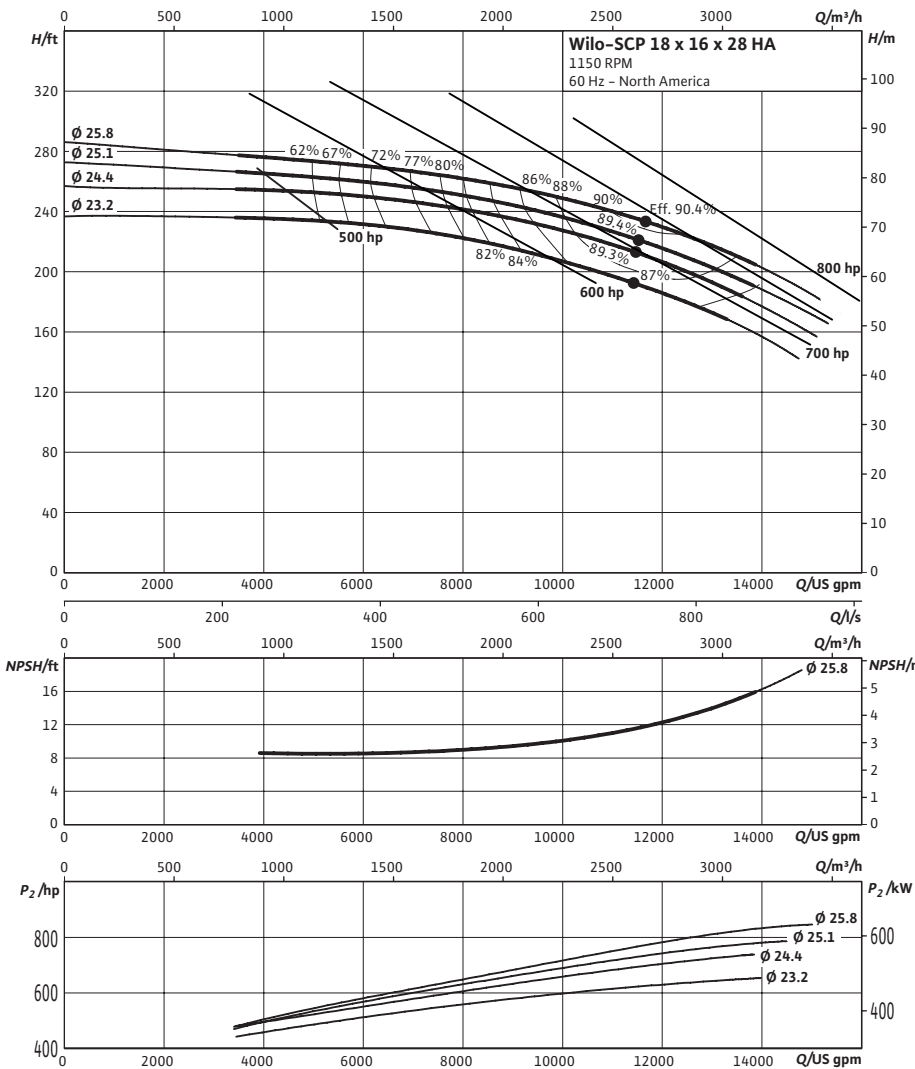

Technical Data

Approved Fluids
 Heating Water
 Cooling and cold water
 Water-Glycol mixtures (for 20-40% glycol and fluid temp ≤ 104°F [40°C])

Fluid Temperature
 Mechanical Seal: 18°F to 250°F (-8°C to 120°C)
 Stuffing Box Packing: 18°F to 220°F (-8°C to 105°C)

Materials of Construction

<input type="checkbox"/>	Pump Housing	A48 Class 35
<input type="checkbox"/>	Pump Housing (Optional)	Ni-resist BS 3468 Gr 2 / BS 2789 500.1
<input type="checkbox"/>	Impeller	BS 84 C83 600
<input type="checkbox"/>	Impeller (optional)	A48 Class 35 / BS 84 C83 600
<input type="checkbox"/>	Stationary Wear Rings	BS 84 C93 700
<input type="checkbox"/>	Pump Shaft	A276 type 410
<input type="checkbox"/>	Pump Shaft (optional)	BS 970 316 S16
<input type="checkbox"/>	Mechanical Seal	Carbon/silicon carbide/EPDM (E1)
<input type="checkbox"/>	Other Mechanical Seals	Avail. on request
<input type="checkbox"/>	Additional Spacer Coupling	Avail. on request
<input type="checkbox"/>	Other:	

Approval Stamp

Dimensional Drawing

Single Stage Pump

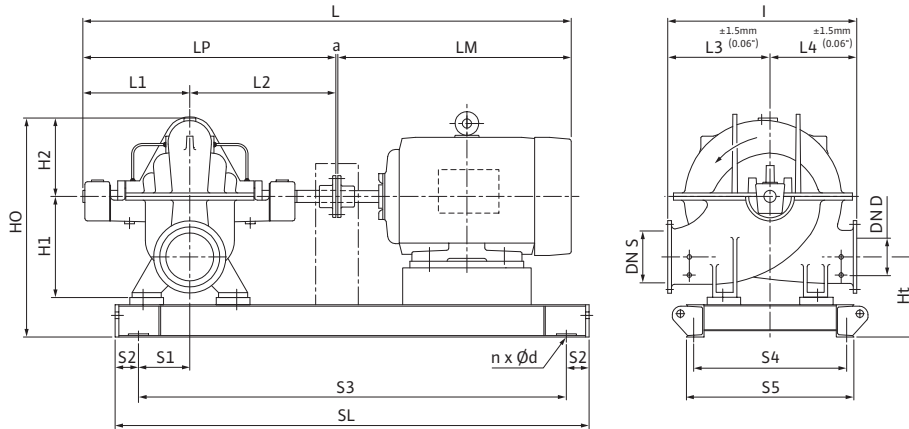

SCP 18 x 16 x 28 HA

Dimensions - Inches (mm)

Frame	a	L	I	L1	L2	L3	L4	LM	LP	H1	H2	HO	Ht	n	Ød	S1	S2	S3	S4	S5	SL	P5	P6
*	.19 (5)	*	64.00 (1626)	27.75 (705)	32.44 (824)	34.00 (864)	30.00 (762)	*	60.19 (1529)	31.50 (800)	22.81 (579)	61.50 (1562)	18.19 (462)	*	*	13.94 (354)	4.00 (102)	*	*	*	*	-	-

* CONSULT FACTORY FOR MOTOR AND DIMENSIONS

Flange Dimensions – Suction Side

Dimensions - Inches (mm)

DN S #125	ØD	Ød	Øk	b	n	D2
18	25.00 (635)	21.00 (533)	23.75 (578)	1.56 (40)	16	1.25 (32)

Flange Dimensions – Discharge Side

Dimensions - Inches (mm)

DN D 125#	ØD	Ød	Øk	b	n	D2
16	23.50 (597)	18.50 (470)	21.25 (540)	1.44 (37)	16	1.13 (29)

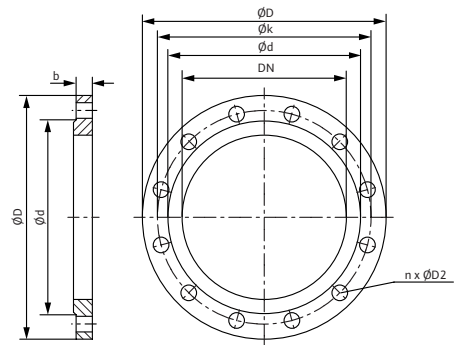

Submittal Data Sheet

Wilo SCP – Horizontal Split Case Pumps



SCP 20 x 16 x 18½ HA

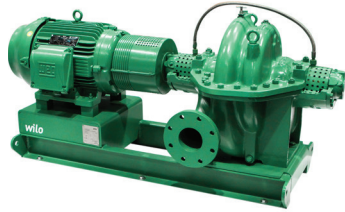

Project:	
Engineer:	
Contractor:	
Submitted By:	Date:
Approved By:	Date:

Tag #	Model #	Flow (USGPM)	Head (Feet)	HP	Enclosure TEFC/ODP	Frame	Cycle	Phase	Voltage	RPM
	SCP 20 x 16 x 18½ HA						60 Hz	3		

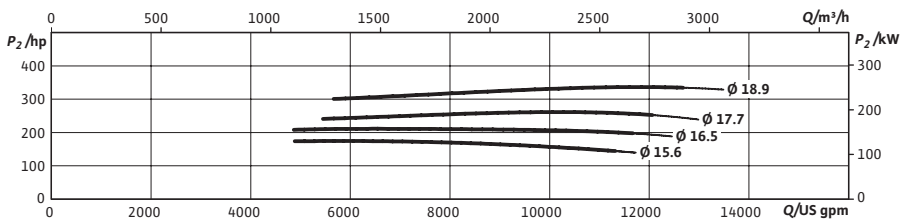
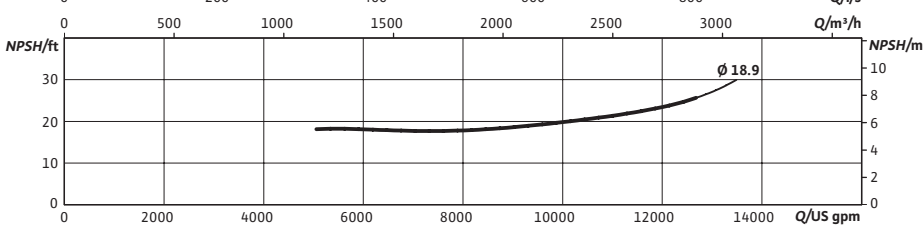
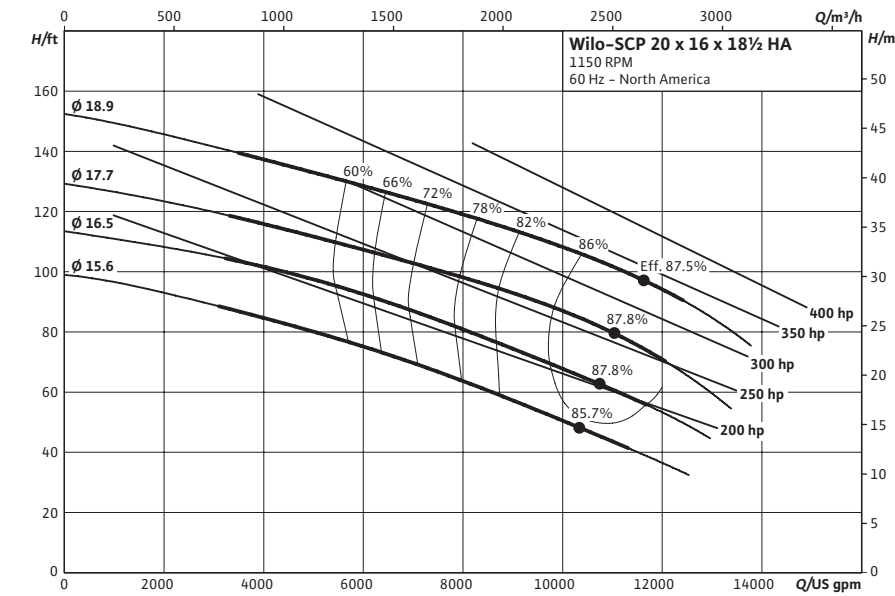

Technical Data

Approved Fluids

- Heating Water
- Cooling and cold water
- Water-Glycol mixtures (for 20–40% glycol and fluid temp ≤ 104°F [40°C])

Fluid Temperature

- Mechanical Seal: 18°F to 250°F (–8°C to 120°C)
- Stuffing Box Packing: 18°F to 220°F (–8°C to 105°C)

Materials of Construction

<input type="checkbox"/> Pump Housing	A48 Class 35
<input type="checkbox"/> Pump Housing (Optional)	Ni-resist BS 3468 Gr 2 / BS 2789 500.1
<input type="checkbox"/> Impeller	BS 84 C83 600
<input type="checkbox"/> Impeller (optional)	A48 Class 35 / BS 84 C83 600
<input type="checkbox"/> Stationary Wear Rings	BS 84 C93 700
<input type="checkbox"/> Pump Shaft	A276 type 410
<input type="checkbox"/> Pump Shaft (optional)	BS 970 316 S16
<input type="checkbox"/> Mechanical Seal	Carbon/silicon carbide/EPDM (E1)
<input type="checkbox"/> Other Mechanical Seals	Avail. on request
<input type="checkbox"/> Additional Spacer Coupling	Avail. on request
<input type="checkbox"/> Other:	

Approval Stamp

Dimensional Drawing

Single Stage Pump

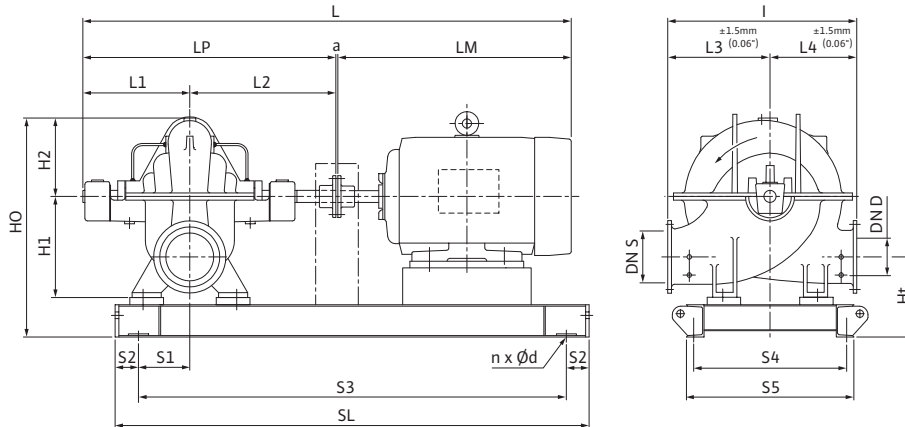

SCP 20 x 16 x 18½ HA

Dimensions – Inches (mm)

Frame	a	L	I	L1	L2	L3	L4	LM	LP	H1	H2	HO	Ht	n	Ød	S1	S2	S3	S4	S5	SL	P5	P6
445T	.50 (13)	108.00 (2743)	52.56 (1335)	24.81 (630)	29.25 (743)	31.13 (791)	21.44 (545)	53.38 (1356)	54.06 (1373)	30.69 (780)	20.50 (521)	58.13 (1477)	20.19 (513)	4	.91 (23)	16.69 (424)	4.00 (102)	78.44 (1992)	31.13 (842)	33.88 (861)	56.44 (2196)	-	-

Additional Motors Available – CONSULT FACTORY

Flange Dimensions – Suction Side

Dimensions – Inches (mm)

DN S #125	ØD	Ød	Øk	b	n	D2
20	27.50 (699)	23.00 (584)	25.00 (635)	1.69 (43)	20	1.25 (32)

Flange Dimensions – Discharge Side

Dimensions – Inches (mm)

DND 125#	ØD	Ød	Øk	b	n	D2
16	23.50 (597)	18.50 (470)	21.25 (540)	1.44 (37)	16	1.13 (29)

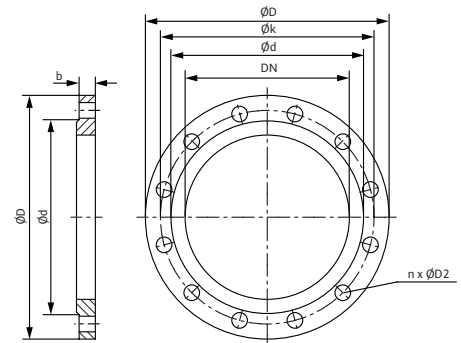

SCP 20 x 16 x 21 HA

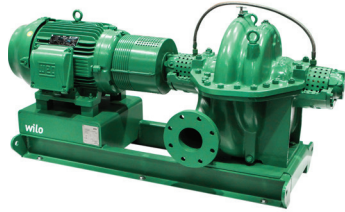

Project:										
Engineer:										
Contractor:										
Submitted By:							Date:			
Approved By:							Date:			

Tag #	Model #	Flow (USGPM)	Head (Feet)	HP	Enclosure TEFC/ODP	Frame	Cycle	Phase	Voltage	RPM
	SCP 20 x 16 x 21 HA						60 Hz	3		

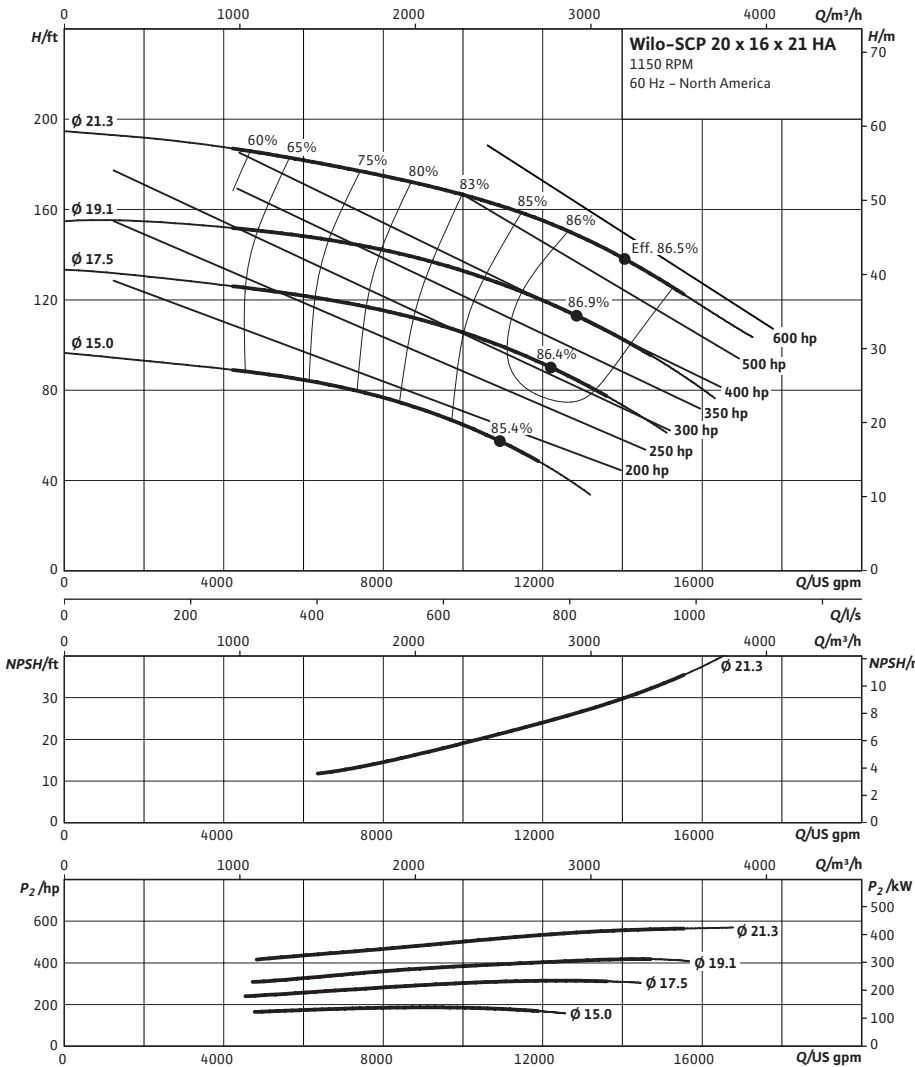

Technical Data

Approved Fluids

- Heating Water
- Cooling and cold water
- Water-Glycol mixtures (for 20-40% glycol and fluid temp ≤ 104°F [40°C])

Fluid Temperature

- Mechanical Seal: 18°F to 250°F (-8°C to 120°C)
- Stuffing Box Packing: 18°F to 220°F (-8°C to 105°C)

Materials of Construction

<input type="checkbox"/> Pump Housing	A48 Class 35
<input type="checkbox"/> Pump Housing (Optional)	Ni-resist BS 3468 Gr 2 / BS 2789 500.1
<input type="checkbox"/> Impeller	BS 84 C83 600
<input type="checkbox"/> Impeller (optional)	A48 Class 35 / BS 84 C83 600
<input type="checkbox"/> Stationary Wear Rings	BS 84 C93 700
<input type="checkbox"/> Pump Shaft	A276 type 410
<input type="checkbox"/> Pump Shaft (optional)	BS 970 316 S16
<input type="checkbox"/> Mechanical Seal	Carbon/silicon carbide/EPDM (E1)
<input type="checkbox"/> Other Mechanical Seals	Avail. on request
<input type="checkbox"/> Additional Spacer Coupling	Avail. on request
<input type="checkbox"/> Other:	

Approval Stamp

Dimensional Drawing

Single Stage Pump

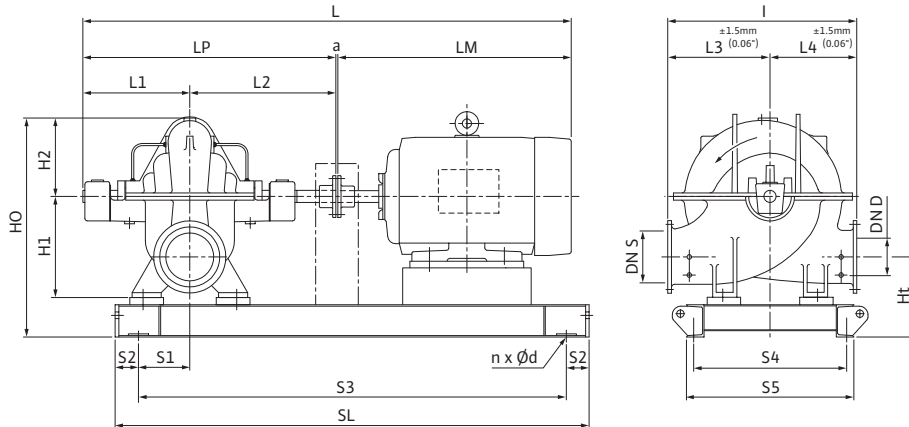

SCP 20 x 16 x 21 HA

Dimensions - Inches (mm)

Frame	a	L	I	L1	L2	L3	L4	LM	LP	H1	H2	HO	Ht	n	Ød	S1	S2	S3	S4	S5	SL	P5	P6
445T	.50 (13)	96.75 (2457)	42.00 (1067)	25.75 (654)	30.88 (784)	25.00 (635)	17.00 (432)	39.63 (1007)	56.63 (1438)	17.19 (437)	19.31 (490)	57.38 (1457)	21.25 (540)	4	.91 (23)	11.44 (291)	9.81 (249)	70.00 (1778)	35.81 (910)	38.50 (978)	89.69 (2278)	-	-

Additional Motors Available – CONSULT FACTORY

Flange Dimensions – Suction Side

Dimensions - Inches (mm)

DN S #125	ØD	Ød	Øk	b	n	D2
20	27.50 (699)	23.00 (584)	25.00 (635)	1.69 (43)	20	1.25 (32)

Flange Dimensions – Discharge Side

Dimensions - Inches (mm)

DND 125#	ØD	Ød	Øk	b	n	D2
16	23.50 (597)	18.50 (470)	21.25 (540)	1.44 (37)	16	1.13 (29)

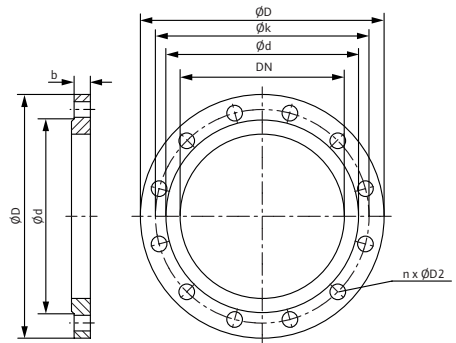

Submittal Data Sheet

Wilo SCP – Horizontal Split Case Pumps



SCP 20 x 16 x 21½ HA

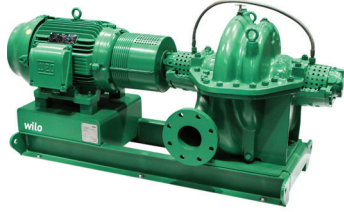

Project:	
Engineer:	
Contractor:	
Submitted By:	Date:
Approved By:	Date:

Tag #	Model #	Flow (USGPM)	Head (Feet)	HP	Enclosure TEFC/ODP	Frame	Cycle	Phase	Voltage	RPM
	SCP 20 x 16 x 21½ HA						60 Hz	3		

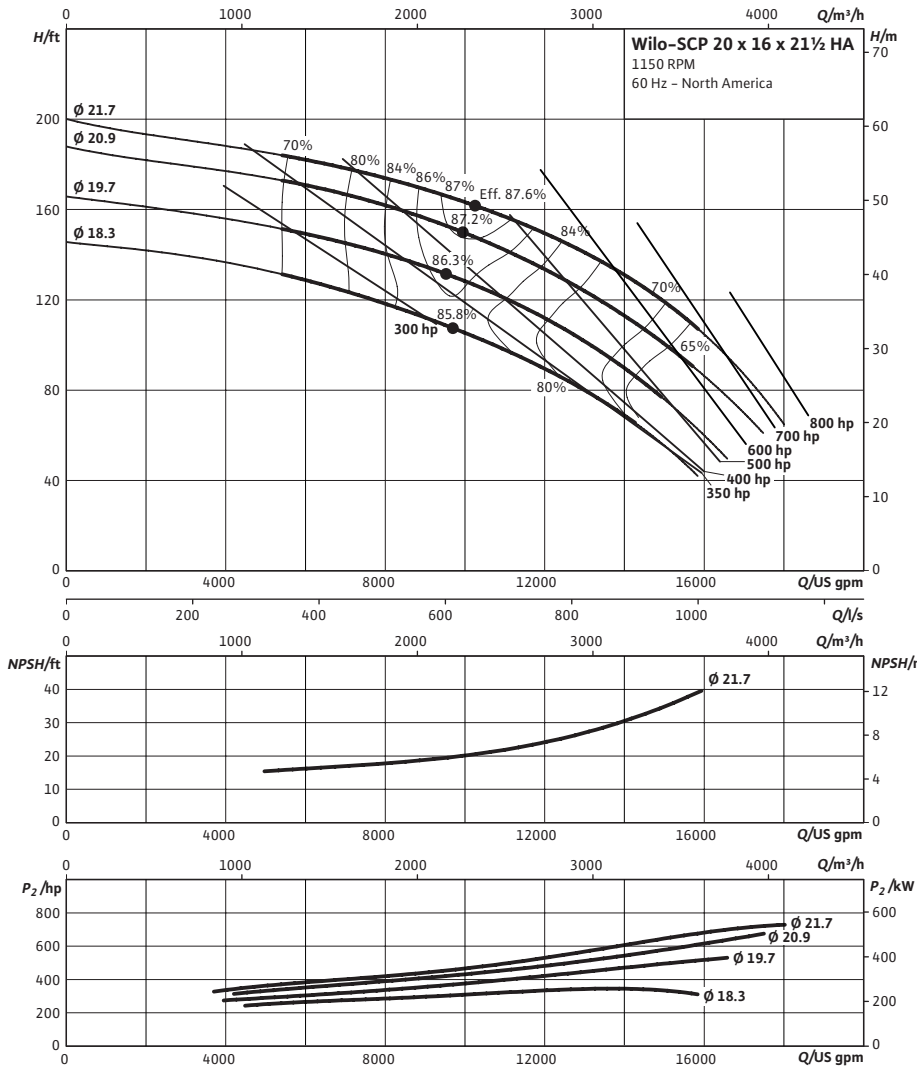

Technical Data

Approved Fluids

Heating Water
Cooling and cold water

Water-Glycol mixtures (for 20-40% glycol and fluid temp ≤ 104°F [40°C])

Fluid Temperature

Mechanical Seal 18°F to 250°F (-8°C to 120°C)
Stuffing Box Packing 18°F to 220°F (-8°C to 105°C)

Materials of Construction

<input type="checkbox"/> Pump Housing	A48 Class 35
<input type="checkbox"/> Pump Housing (Optional)	Ni-resist BS 3468 Gr 2 / BS 2789 500.1
<input type="checkbox"/> Impeller	BS 84 C83 600
<input type="checkbox"/> Impeller (optional)	A48 Class 35 / BS 84 C83 600
<input type="checkbox"/> Stationary Wear Rings	BS 84 C93 700
<input type="checkbox"/> Pump Shaft	A276 type 410
<input type="checkbox"/> Pump Shaft (optional)	BS 970 316 S16
<input type="checkbox"/> Mechanical Seal	Carbon/silicon carbide/EPDM (E1)
<input type="checkbox"/> Other Mechanical Seals	Avail. on request
<input type="checkbox"/> Additional Spacer Coupling	Avail. on request
<input type="checkbox"/> Other:	

Approval Stamp

Dimensional Drawing

Single Stage Pump

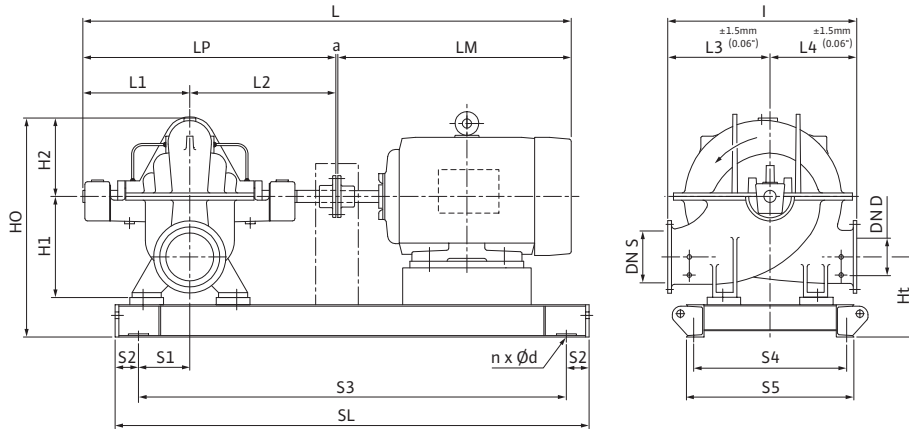

SCP 20 x 16 x 21½ HA

Dimensions – Inches (mm)

Frame	a	L	I	L1	L2	L3	L4	LM	LP	H1	H2	HO	Ht	n	Ød	S1	S2	S3	S4	S5	SL	P5	P6
*	.19 (5)	*	51.94 (1319)	27.44 (697)	32.69 (830)	29.94 (748)	22.06 (560)	*	60.06 (1526)	30.75 (781)	19.50 (495)	57.44 (1459)	19.44 (494)	*	*	16.69 (424)	4.00 (102)	*	*	*	*	-	-

* CONSULT FACTORY FOR MOTOR AND DIMENSIONS

Flange Dimensions – Suction Side

Dimensions – Inches (mm)

DN S #125	ØD	Ød	Øk	b	n	D2
20	27.50 (699)	23.00 (584)	25.00 (635)	1.69 (43)	20	1.25 (32)

Flange Dimensions – Discharge Side

Dimensions – Inches (mm)

DN D 125#	ØD	Ød	Øk	b	n	D2
16	23.50 (597)	18.50 (470)	21.25 (540)	1.44 (37)	16	1.13 (29)

