

Pioneering for You

wilo

Consulting guide

Wilo-Stratos MAXO



NOW. PUMP TECHNOLOGY OF THE FUTURE

WILO-STRATOS MAXO: THE WORLD'S FIRST SMART PUMP*.



Your new partner is the most flexible pump: the Wilo-Stratos MAXO is the perfect fit for any application and ensures optimal system efficiency thanks to its intelligent control mode. Furthermore, the pump can be integrated into all relevant systems due to diverse interfaces. And with optimised and innovative energy-saving features the Wilo-Stratos MAXO meets the changing requirements superbly. No other pump on the market offers you more efficiency, connectivity and convenience. This is how already today we are making your life easier with the innovations of tomorrow.

WILO BRINGS THE FUTURE.

Discover the future of pump technology:
www.wilo.com/wilo-stratos-maxo

* We understand a smart-pump as a new category of pumps, which goes far beyond our high-efficiency pumps or pumps with pump intelligence. Only the combination of the latest sensor technology and innovative control functions (e.g. Dynamic Adapt plus and Multi-Flow Adaptation), bidirectional connectivity (e.g. Bluetooth, integrated analogue inputs, binary inputs and outputs, Wilo Net interface), software updates and excellent usability (e.g. thanks to the Setup Guide, the preview principle for predictive navigation and the tried and tested Green Button Technology) make this pump a smart-pump.

Pioneering for You

wilo

Planungshinweise

Applications and fields of application

Introduction		5
Applications	Heating	5
	Cooling	5
	Drinking water	5
Fields of application	Permitted fluids	5
	Viscous fluids	6
	Permitted operating temperatures	6
	Installation environment	6
	System pressure (rated pressure)	6

Dimensioning of the Stratos MAXO

Hydraulic dimensioning	Minimum inlet pressure	7
	Flow rates	7

Functions of the Stratos MAXO

Application-related control modes	Application-based control mode setting	7	
	Heating: Radiator consumer circuit	8	
	Heating: Underfloor heating consumer circuit	8	
	Heating: Ceiling heating consumer circuit	9	
	Heating: Fan heater consumer circuit	10	
	Heating: Generator or feeder circuit with heat exchange	10	
	Heating: Generator or feeder circuit with hydraulic shunt	12	
	Cooling: Ceiling cooling consumer circuit	13	
	Cooling: Underfloor cooling consumer circuit	14	
	Cooling: Air-conditioning device consumer circuit	15	
	Cooling: Generator or feeder circuit with heat exchanger	15	
	Cooling: Generator or feeder circuit with hydraulic shunt	15	
	Basic control modes	Drinking water: Circulation	15
		Differential pressure Δp -c	16
		Index circuit Δp -c	16
		Differential pressure Δp -v	16
		Dynamic Adapt plus	17
		Temperature T-const	17
		Temperature ΔT -const	17
Volume flow Q-const		18	
Multi-Flow Adaptation		18	
Speed n-const	18		
PID control	18		

Additional functions for the control modes	No-Flow Stop	18
	Automatic detection of setback operation	19
	Nominal duty point in Δp -v control	19
	Q-Limit Min (minimum volume flow limit)	19
	Q-Limit Max (maximum volume flow limit)	19
	Switching between heating/cooling	20
	Detection of thermal disinfection	20
Data collection functions of the Stratos MAXO	Heating/cooling quantity measurement	20
Pump functions independent of the control mode	Double pump management	21
	Automatic venting of the pump	21
	Pump kick	21
Stratos MAXO accessories	Thermal insulation for heating and domestic hot water circulation applications	21
	Diffusion-proof insulation for cold water application when cooling	21
	PT 1000 AA immersion temperature sensor for heating/cooling with immersion sleeve	22
	PT 1000 B pipe surface contact sensor to detect thermal disinfection	22
	Room user interface for T-const hall temperature control	22
	Differential pressure sensor for the Δp -c index circuit evaluator	23
	CIF module for BUS connection to building automation	23

Installation

Hydraulic installation	Pipe installation	23
	Permitted installation positions	26
	Installation dimensions of the Stratos MAXO	26
Electrical connections and interfaces	Electrical mains connection	26
	Motor protection	27
	Connection of accessories to AI1 and AI2 analogue inputs	27
	Connection of digital input DI1 and DI2	27
	Connection of potential-free contact for SSM and SBM	27
	Connection of Wilo Net BUS system	28
	Installation and cabling of CIF module	28

1 Consulting guide

2 Applications and fields of application

2.1 Introduction

The Stratos MAXO series is a high efficiency glandless pump and the world's first smart-pump*. With its optimised and innovative energy-saving functions, it sets new energy efficiency standards for heating, cooling and drinking water applications. Furthermore, the outstanding user-friendliness offers a hitherto unparalleled ease of operation.

The Stratos MAXO can be installed as a circulator in heating, cooling, air conditioning and domestic hot water circulation systems in residential buildings as well as in hospitals, commercial and public buildings, schools and large properties.

2.2 Applications

2.2.1 Heating

When appropriately dimensioned, the Stratos MAXO ensures sufficient volume flow at all times in heat generator circuits, heat source circuits, distribution circuits or heating circuits with consumers in rooms, while at the same time avoiding system noises and significantly reducing energy costs.

Due to its corrosion-resistant stainless steel pump housing, the Wilo Stratos MAXO-Z is also suitable for use in installations where oxygen entry is possible, e.g. open heating systems.

2.2.2 Cooling

When appropriately dimensioned, the Stratos MAXO ensures sufficient volumetric flow at all times in cooling applications with cold water, e.g. in cooling generator circuits, heat sink circuits, distribution circuits or cooling circuits with consumers in the room.

Condensation water forms on cold surfaces if the fluid temperature in the pump and the pipe network falls below the ambient temperature. The Wilo Stratos MAXO can also be used in such cases. The pump's design prevents condensation water from damaging its electronic components.

* By "smart-pump", we mean a new category of pumps that outperforms our high-efficiency pumps and our pumps with pump intelligence by a considerable margin. The combination of the latest sensor technology and innovative control functions (e.g. Dynamic Adapt plus and Multi-Flow Adaptation), bi-directional connectivity (e.g. Bluetooth, integrated analogue inputs, binary inputs/outputs, Wilo Net interface), software updates and outstanding user-friendliness (e.g. Setup Guide, preview principle for anticipatory navigation and the tried and tested Green Button Technology) are what make this pump a smart-pump.

Corrosion-proof pump design

Corrosion-proof versions are required for cooling applications, for example. The pump housing is equipped with a special coating (KTL: cathodic coating) for this purpose. This provides optimal protection against corrosion caused by the formation of condensation water on the pump housing in cold-water installations, and is highly scratch and knock resistant.

Alternatively, the Wilo-Stratos MAXO-Z with corrosion-resistant stainless steel pump housing can be used as the highest-quality version.

2.2.3 Drinking water

Pumps installed in domestic hot water circulation systems are subject to specific requirements, which the Wilo-Stratos MAXO-Z duly fulfils.

All plastic parts that come into contact with pumped fluid comply with the German Federal Health Agency's recommendations. All metal parts that are water-wetted correspond to normative and regulatory requirements.

2.3 Fields of application

2.3.1 Permitted fluids

→ The Stratos MAXO is resistant to heating water pursuant to the German guideline VDI 2035 Parts 1 and 2.

→ The Stratos MAXO is resistant to demineralised water. Guideline VDI 2035 describes demineralised water as follows:

- Fill-up and make-up water for warm water heating systems pursuant to VDI 2035-2 Chapter 8.1 "Water quality" Table 1 "Operation with low salt content".
- Electrical conductivity at 25 °C: 10 – 100 µS/cm
 - Appearance: free of sediment
 - pH value at 25 °C: 8.2 – 10.0^{1) 2)}
 - Oxygen: < 0.1 mg/l³⁾

Reference values for hot water		
	Low-salt	Salty
Electrical conductivity at 25 °C	< 100 µS/cm	100 – 1500 µS/cm
Appearance	free of sediment	free of sediment
pH value at 25 °C	8.2 – 10.0	8.2 – 10.0
Oxygen	< 0.1 mg/l	< 0.02 mg/l

1) For aluminium and aluminium alloys, the pH value range is restricted – see also Section 7.4. "... for pH values > 8.5, even when no oxygen is present, aluminate [Al(OH)₄]-forms due to the generation of hydrogen. As aluminate is soluble, no covering layers form. As a consequence of the raised pH value of the hot water, the corrosion of the aluminium continues unchecked." For this reason, as a fundamental rule no aluminium should be used for parts in contact with water.

2) The fluid must be subjected to a pH value treatment in accordance with VDI 2035!

3) For proper planning, installation, regular maintenance and repair it should be assumed that the oxygen content in regular operation of systems that are closed from a corrosion perspective is set to values under 0.02 mg/l.

- The Stratos MAXO is resistant to water-glycol mixtures for cooling applications or for use in geothermal circuits. These water-glycol mixtures are produced by different manufacturers; the mixtures' characteristics, substances and concentrations vary slightly and must be used in accordance with the manufacturers' recommendations.
- Various fluids can be used for the application of e.g. heat pumps in geothermal circuits. Due to environmental protection requirements, the fluid to be used for this purpose depends on the heat pump system's location. The preferred fluids are water-glycol mixtures. They must be used in accordance with the manufacturers' recommendations.
- If salty fluids containing carbonate, acetate or formate are used, the fluid temperature must remain below 40 °C. In addition, a corrosion inhibitor must be used. Salty fluids are far more corrosive than water-glycol mixtures. Temperatures over 40 °C can lead to severe corrosive effects. The proportion of corrosion inhibitor present must therefore be continuously monitored.
- The Stratos MAXO-Z is suitable for applications in domestic hot water installations with due regard to the German Federal Environment Agency (Umweltbundesamt – UBA) guidelines on operating conditions in domestic hot water circulation systems. This relates to drinking water pursuant to the EU Drinking Water Directive and clean, non-aggressive, low-viscosity fluids in accordance with national drinking water provisions. In order to disinfect the drinking water network, the pump must be removed and the provisions of DVGW-W557 observed.

2.3.2 Viscous fluids

All pump curves included in the Wilo catalogue relate to the pumping of water (kinematic viscosity = 1 mm²/s). The hydraulic values of the pump and the pipe system will deviate when pumping fluids of different density and/or viscosity (e.g. water-glycol mixtures). This must be taken into account when configuring and adjusting the pump.

2.3.3 Permitted operating temperatures

The permitted fluid temperature range extends from -10 °C to +110 °C without restriction at an ambient temperature of -10 °C to a maximum of +40 °C.

2.3.4 Installation environment

In terms of its electromagnetic compatibility, the Stratos MAXO complies with regulations on emitted interference for residential, business and commercial environments as well as light-industrial environments (C1) and interference resistance for industrial environments (C2), pursuant to EN 61800-3:2004.

It can therefore be installed and operated in the aforementioned building types.

Installation within a building:

The Stratos MAXO should be installed in a dry, well ventilated and dust-free room – in accordance with the IP X4D protection class. Ambient temperatures below -10 °C are not permitted.

Installation outside a building (outdoor installation):

- The Stratos MAXO should be installed in a chamber (e.g. light well, ring chamber) with a cover or in a chamber or housing to protect against the weather.
- Ambient temperatures below -10 °C are not permitted.
- Avoid exposing the Stratos MAXO to direct sunlight.
- The Stratos MAXO should be protected in such a way that condensation drain grooves remain free from dirt.
- Protect the Stratos MAXO against rain and snow.
- Implement suitable measures to prevent the formation of condensation water.

2.3.5 System pressure (rated pressure)

The maximum system pressure (rated pressure) for the Wilo-Stratos MAXO is listed in the respective descriptions of each individual model in the product catalogue and the price list. The Wilo-Stratos MAXO is available in the following rated pressure classes: PN 6, PN 10 and PN 16.

3 Dimensioning of the Stratos MAXO

3.1 Hydraulic dimensioning

The best overall efficiency of the circulator is in the middle third of the duty chart, close to the maximum pump curve. The design point should therefore always be close to the maximum pump curve.

For systems with a constant volume flow (e.g. a generator circuit), the design point should be in the middle third of the duty chart, in Area II.

For systems with a variable volume flow, the design point should be in Area III. The actual duty point is then also usually in Area III.

Duty point in pump's duty chart with variable volume flow

Area I (left-hand third)

Choose a smaller pump if the duty point is in this area.

Area II (middle third)

The pump will operate in the optimal operating area for 98 % of the operating time.

Area III (right-hand third)

The controlled pump will only operate in the least efficient operating area at its design point (on the warmest/coldest day of the year), i.e. for 2 % of its operating time.

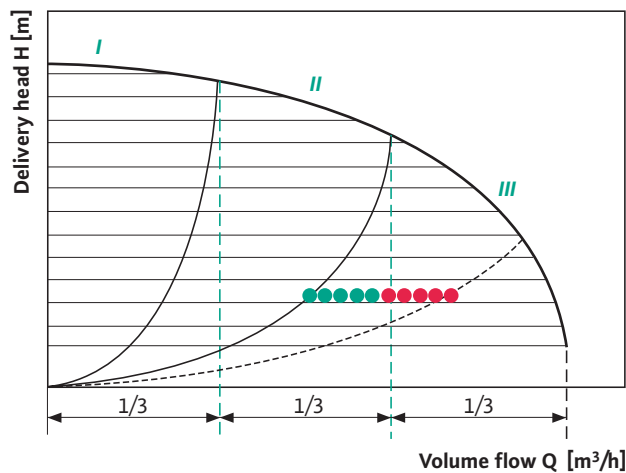

The duty point shifts into Area II (middle third).

3.1.1 Minimum inlet pressure

To prevent cavitation (vapour bubble formation within the pump), it is necessary to maintain a sufficiently high overpressure (positive suction head) at the pump suction port in relation to the vapour pressure of the fluid being pumped.

Minimum inlet pressure (above atmospheric pressure) at the pump's suction port to avoid cavitation noises (at fluid temperature):

Stratos MAXO	Fluid temperature		
	-20 °C...+50 °C	up to +95 °C	up to +110 °C
Nominal diameter			
Rp 1	0.3 bar	1.0 bar	1.6 bar
Rp 1 ¼	0.3 bar	1.0 bar	1.6 bar
DN 32 (H _{max} = 8 m, 10 m, 12 m)	0.3 bar	1.0 bar	1.6 bar
DN 32 (H _{max} = 16 m)	0.5 bar	1.2 bar	1.8 bar
DN 40 (H _{max} = 4 m, 8 m)	0.3 bar	1.0 bar	1.6 bar
DN 40 (H _{max} = 12 m, 16 m)	0.5 bar	1.2 bar	1.8 bar
DN 50 (H _{max} = 6 m)	0.3 bar	1.0 bar	1.6 bar
DN 50 (H _{max} = 8 m, 9 m, 12 m)	0.5 bar	1.2 bar	1.8 bar
DN 50 (H _{max} = 14 m, 16 m)	0.7 bar	1.5 bar	2.3 bar
DN 65 (H _{max} = 6 m, 9 m)	0.5 bar	0.9 bar	2.3 bar
DN 65 (H _{max} = 12 m, 16 m)	0.7 bar	1.5 bar	2.3 bar
DN 80	0.7 bar	1.5 bar	2.3 bar
DN 100	0.7 bar	1.5 bar	2.3 bar

NOTICE!

Effective up to 300 m above sea-level. For higher altitudes, +0.01 bar/100 m increase in height.

In case of higher fluid temperatures, fluids of lower density, higher flow resistances or lower atmospheric pressure, adjust the values accordingly.

The maximum installation height is 2000 metres above mean sea level (MSL).

3.1.2 Flow rates

The pipe network and the suitable pump are configured according to recognised technical rules and standards. The flow rates for the respective hydraulic sections described therein must be observed.

4 Functions of the Stratos MAXO

4.1 Application-related control modes

Finding the optimal control mode for a specific application is often not a simple, straight-forward task. By contrast, the pump's prospective application is known. This serves as a simple orientation, and the Stratos MAXO can be configured based on this application. The Stratos MAXO includes a number of standard and new control modes in order to guarantee optimal pump operation in every application. The control modes can be divided into the following basic groups:

- Pressure control modes, such as Δp -v, Δp -c, Dynamic Adapt Plus
- Volume flow control modes, such as Q-const
- Fluid temperature control modes, such as ΔT -const or T-const
- Hall temperature control modes

In addition to these basic control modes, a range of additional functions can also be activated: Q-Limit, No-Flow Stop, etc.

The control modes are described in detail in the following.

4.1.1 Application-based control mode setting

The Stratos MAXO contains a range of pre-configured control modes suitable and specially configured for several applications:

- Heating
 - Radiator
 - Underfloor heating
 - Ceiling heating
 - Fan heater
 - Heat exchanger
 - Hydraulic shunt
- Cooling
 - Ceiling cooling
 - Underfloor cooling
 - Air-conditioning device
 - Heat exchanger
 - Hydraulic shunt
- Drinking water
 - Circulation

4.1.2 Heating: Radiator consumer circuit

Description

The pump is installed in a consumer circuit that supplies a static heating system with radiators. The $\Delta p-v$, Dynamic Adapt plus or T-const constant hall temperature control modes could be selected for this application.

Pressure control

If the heating circuit supplies multiple rooms, the radiators will be fitted with control valves to regulate the individual rooms' temperatures. In this case, $\Delta p-v$ (nominal delivery head setting required) or Dynamic Adapt plus (nominal delivery head setting not required) could be selected. For this application, Wilo recommends the Dynamic Adapt plus control mode.

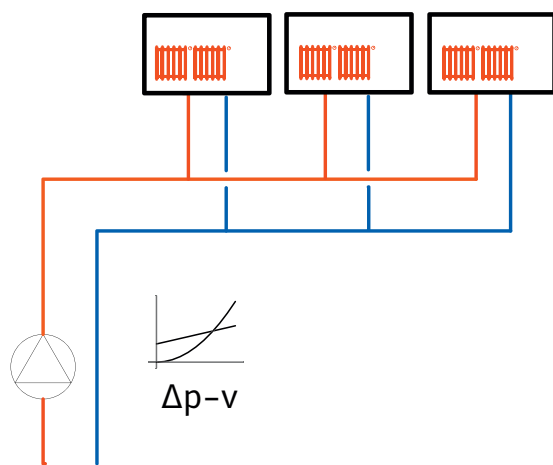

Pressure control in a radiator consumer circuit

Hall temperature control modes

If the heating circuit supplies heat to a large thermal zone, e.g. a hall, the control valves on the radiators are redundant or are not present in an existing building. The pump can then directly regulate the hall temperature to the desired setpoint using the T-const constant hall temperature control mode. In addition, it is necessary to install a temperature sensor or a room user interface in the hall to measure the temperature and act as a setpoint controller. These values are transmitted to the pump via the analogue inputs. The temperature sensor to measure the actual temperature can either be connected directly as a PT1000 sensor or as an active sensor with 0...10 V and 4...20 mA. The setpoint can be transmitted as a 0...10 V or 4...20 mA signal. If a setpoint controller is not installed in the room, the setpoint can also be set in the pump as a fixed value. Further information on room user interfaces can be found in the "Accessories" chapter.

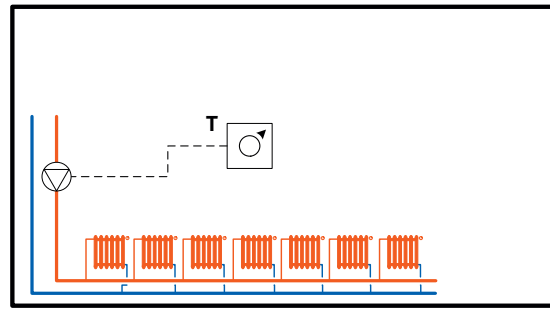

Hall temperature control in a radiator consumer circuit

4.1.3 Heating: Underfloor heating consumer circuit

The pump is installed in a consumer circuit that supplies a slow surface heating system, e.g. underfloor heating. The basic control modes $\Delta p-c$, Dynamic Adapt plus or T-const constant hall temperature can be used for this application.

Pressure control

If the heating circuit supplies multiple rooms, the radiators will be fitted with control valves to regulate the individual rooms' temperatures. In this case, $\Delta p-c$ (nominal delivery head setting required) or Dynamic Adapt plus (nominal delivery head setting not required) could be selected. For this application, Wilo recommends the Dynamic Adapt plus control mode.

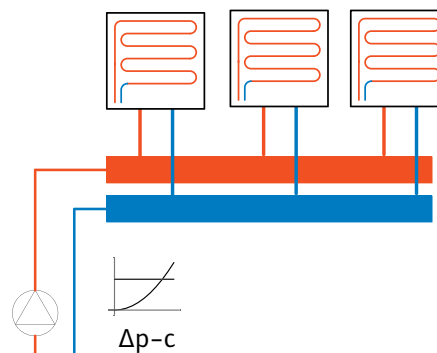

Pressure control in an underfloor heating consumer circuit

Hall temperature control

If the heating circuit supplies heat to a large thermal zone, e.g. a hall, the control valves on the underfloor heating's distributor connections are redundant and are often not present in existing buildings. The pump can then directly control the temperature to reach the desired setpoint using the T-const constant hall temperature control mode. In addition, it is necessary to install a temperature sensor or a room user interface in the hall to measure the temperature and act as a setpoint controller. These values are transmitted to the pump via the analogue inputs. The temperature sensor to measure the actual temperature can either be connected directly as a PT1000 sensor or as an active sensor with 0...10 V and 4...20 mA. The setpoint can be transmitted as a 0...10 V or 4...20 mA signal. If a setpoint controller is not installed in the room, the setpoint can also be set in the pump as a fixed value.

Further information on room user interfaces can be found in the "Accessories" chapter.

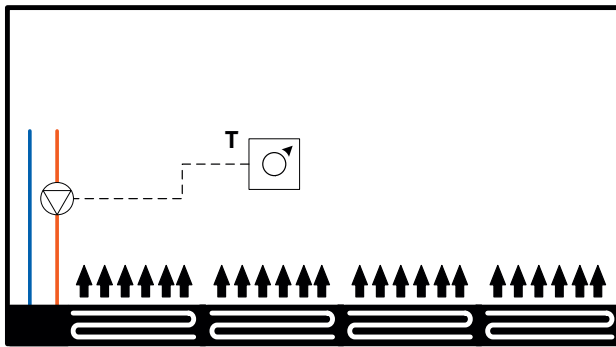

Hall temperature control in an underfloor heating consumer circuit

4.1.4 Heating: Ceiling heating consumer circuit

The pump is installed in a consumer circuit that supplies a ceiling heating. The control modes $\Delta p-c$, Dynamic Adapt plus or T-const constant hall temperature can be used for this application.

Pressure control

If the heating circuit supplies multiple rooms, the ceiling heating circuits will be fitted with control valves to regulate the individual rooms' temperatures. In this case, $\Delta p-c$ (nominal delivery head setting required) or Dynamic Adapt plus (nominal delivery head setting not required) could be selected. For this application, Wilo recommends the Dynamic Adapt plus control mode.

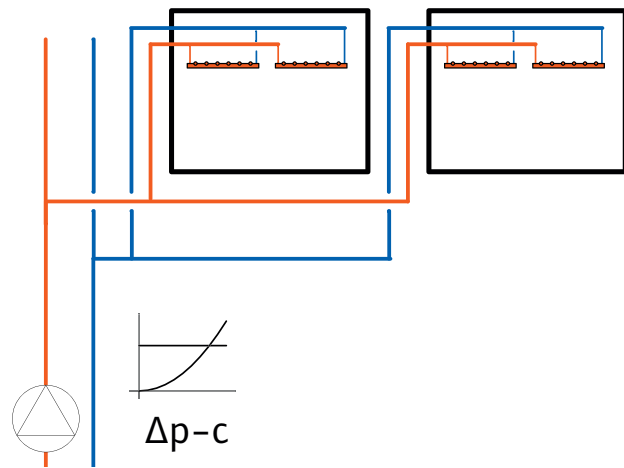

Pressure control in a ceiling heating consumer circuit

Hall temperature control modes

If the heating circuit supplies heat to a large thermal zone, e.g. a hall, the control valves on the ceiling heating's distributor connections are redundant and are often not present in existing buildings. The pump can then directly regulate the hall temperature to the desired setpoint using the T-const constant hall temperature control mode. In addition, it is necessary to install a temperature sensor or a room user interface in the hall to measure the temperature and act as a setpoint controller. These values are transmitted to the pump via the analogue inputs. The temperature sensor to measure the actual temperature can either be connected directly as a PT1000 sensor or as an active sensor with 0...10 V and 4...20 mA. The setpoint can be transmitted as a 0...10 V or 4...20 mA signal. If a setpoint controller is not installed in the room, the setpoint can also be set in the pump as a fixed value.

Further information on room user interfaces can be found in the "Accessories" chapter.

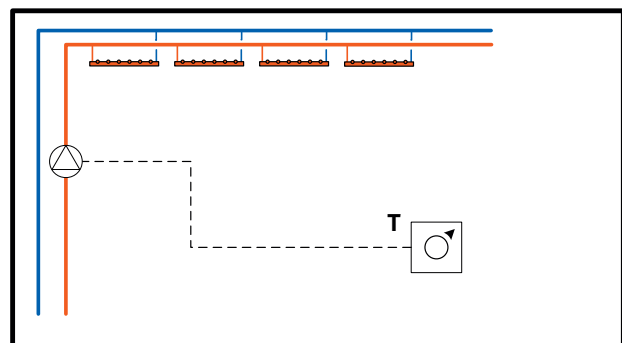

Hall temperature control in a ceiling heating consumer circuit

4.1.5 Heating: Fan heater consumer circuit

The pump is installed in a consumer circuit that supplies very fast air heating, e.g. a fan heater. The $\Delta p-v$, Dynamic Adapt plus or T-const constant hall temperature control modes could be selected for this application.

Pressure control

If the heating circuit supplies multiple rooms, the radiators will be fitted with control valves to regulate the individual rooms' temperatures. In this case, $\Delta p-v$ (nominal delivery head setting required) or Dynamic Adapt plus (nominal delivery head setting not required) could be selected. For this application, Wilo recommends the Dynamic Adapt plus control mode.

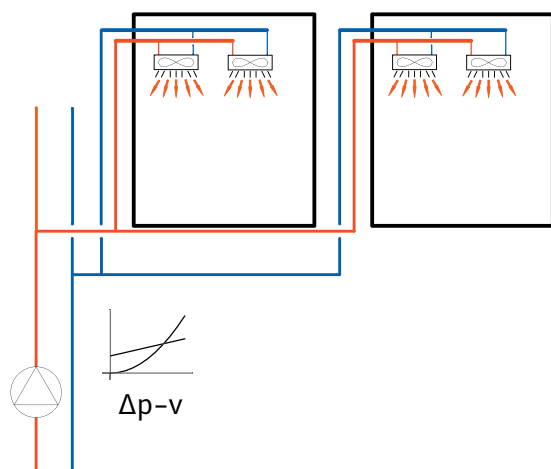

Pressure control in a fan heater consumer circuit

Hall temperature control modes

If the heating circuit supplies heat to a large thermal zone, e.g. a hall, the control valves on the fan heaters are redundant and are often not present in existing buildings. The pump can then directly regulate the hall temperature to the desired setpoint using the T-const constant hall temperature control mode. In addition, it is necessary to install a temperature sensor or a room user interface in the hall to measure the temperature and act as a setpoint controller. These values are transmitted to the pump via the analogue inputs. The temperature sensor to measure the actual temperature can either be connected directly as a PT1000 sensor or as an active sensor with 0...10 V and 4...20 mA. The setpoint can be transmitted as a 0...10 V or 4...20 mA signal. If a setpoint controller is not installed in the room, the setpoint can also be set in the pump as a fixed value. Further information on room user interfaces can be found in the "Accessories" chapter.

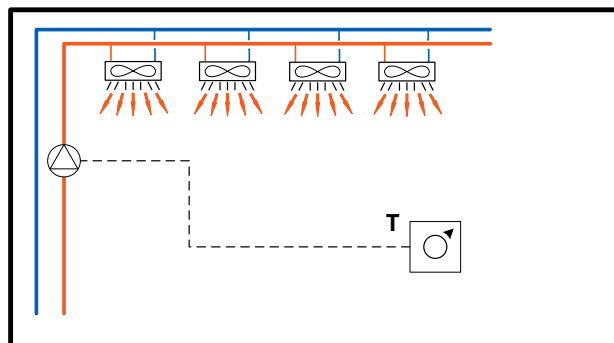

Hall temperature control in a fan heater consumer circuit

4.1.6 Heating: Generator or feeder circuit with heat exchanger

The pump is installed in a generator or feeder circuit (primary circuit) that supplies a heat exchanger with heat. Heat exchangers are installed to separate two hydraulic systems and transfer thermal energy from one system to another. In this context, a distinction must be made between two objectives:

1. The feed temperature is to be set on the secondary side. This is the case, for example, in an underfloor heating circuit which is supplied from one distributor along with static heating circuits. To do this, the volume flow on the primary side must be reduced accordingly. The Stratos MAXO provides the fluid temperature control function for this purpose.
2. The energy is to be transferred without raising the return temperature if at all possible. In this case, it is necessary to adjust the volume flow on the primary side according to that on the secondary side. The Stratos MAXO provides the ΔT and Multi-Flow Adaptation functions for this purpose.

Temperature control: Constant secondary feed temperature T-const

The feed temperature behind the heat exchanger (secondary side) is regulated to the defined setpoint by adjusting the speed of the pump upstream of the heat exchanger (primary side). It is also necessary to install a temperature sensor (PT1000 or active sensor with 0...10 V and 4...20 mA output) in the secondary feed. The pump is connected via one of the two analogue inputs.

An immersion temperature sensor with suitable immersion sleeves is described in the "Accessories" chapter.

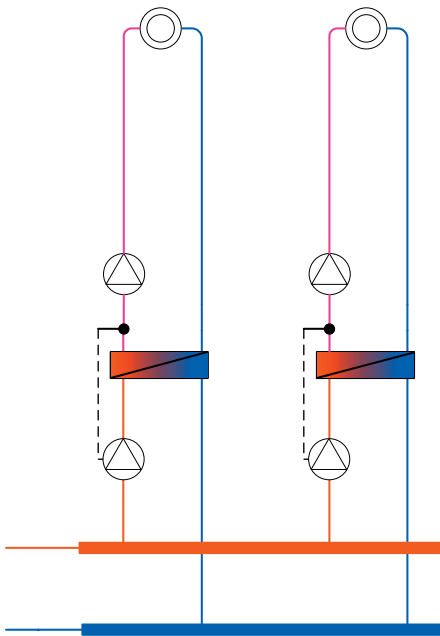

Heating: Temperature control T-const behind the heat exchanger

Temperature control: ΔT -const between primary side feed and secondary side feed

The temperature difference between the heat exchanger's primary and secondary feeds is controlled to reach the defined setpoint. The volume flow in the primary circuit is thereby aligned with the secondary volume flow.

It is therefore necessary to install a temperature sensor (PT1000 or active sensor with 0...10 V and 4...20 mA output) in both the primary and secondary feeds. The sensors in the pump can be used for the primary side, meaning that the temperature sensor is connected to the pump on the secondary side. The connection to the pump is made via the two analogue inputs.

An immersion temperature sensor with suitable immersion sleeves is described in the "Accessories" chapter.

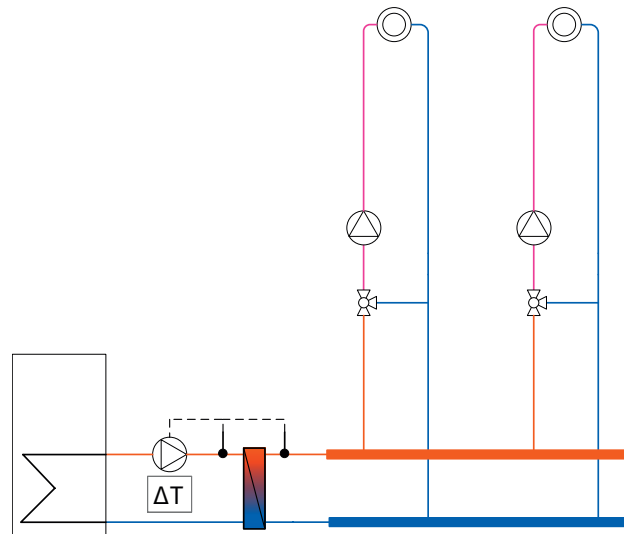

Temperature control ΔT -const of inputs via a heat exchanger

Multi-Flow Adaptation

With the Multi-Flow Adaptation control mode, the volume flow in the generator/feeder circuit (primary circuit) is aligned with the volume flow in the consumer circuits (secondary circuit). Multi-Flow Adaptation is set in the Stratos MAXO feeder pump in the primary circuit upstream of the heat exchanger. The Stratos MAXO feeder pump is connected to the Stratos MAXO pumps in the secondary circuits via a data cable. The feeder pump continuously receives the respective required volume flow from each individual secondary pump in short intervals. The sum of the required volume flows from all secondary pumps is set by the feeder pump as the target volume flow. On commissioning, all associated secondary pumps must be connected to the primary pump so that it can take their volume flows into consideration. A fixed volume flow requirement can be entered for non-communication-capable secondary pumps so that their flows are also taken into consideration.

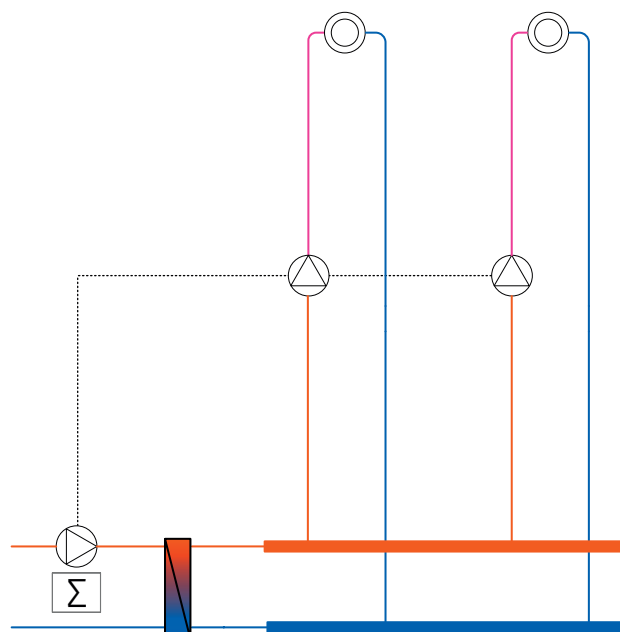

Multi-Flow Adaptation of the feeder pump in front of a heat exchanger with secondary pumps in the line without mixer

4.1.7 Heating: Generator or feeder circuit with hydraulic shunt

The pump is installed in a generator or feeder circuit that supplies a hydraulic shunt with heat. Hydraulic shunts are installed to hydraulically decouple two systems. In this context, a distinction must be made between two objectives:

1. The feed temperature is to be set on the secondary side. This is the case, for example, for underfloor heating circuits which are supplied by a high-temperature distributor. To do this, the volume flow on the primary side must be reduced accordingly in relation to the secondary side. The Stratos MAXO provides the fluid temperature control function for this purpose.
2. The energy is to be transferred without raising the return temperature if at all possible. In this case, it is necessary to adjust the volume flow on the primary side according to that on the secondary side. The Stratos MAXO provides the ΔT and Multi-Flow Adaptation functions for this purpose.

Temperature control: Constant secondary feed temperature T-const

The feed temperature behind the hydraulic shunt (secondary side) is regulated to the defined setpoint by adjusting the speed of the pump in front of the shunt. It is also necessary to install a temperature sensor (PT1000 or active sensor with 0...10 V and 4...20 mA output) in the secondary feed. The pump is connected via one of the two analogue inputs.

An immersion temperature sensor with suitable immersion sleeves is described in the “Accessories” chapter.

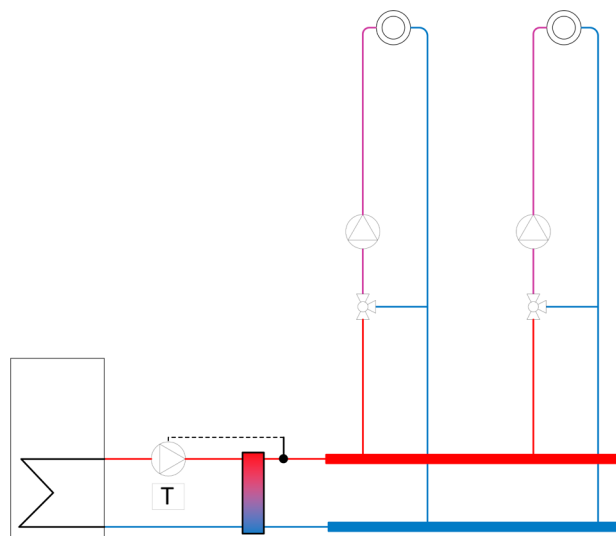

Temperature control T-const of feeder pump via hydraulic shunt

Temperature control: ΔT -const between primary side return flow and secondary side return flow

The temperature difference between the hydraulic shunt primary and secondary return flows is controlled to reach the defined setpoint. The volume flow in the primary circuit is thereby aligned with the secondary volume flow. It is therefore necessary to install two temperature sensors (PT1000 or active sensor with 0...10 V and 4...20 mA output) in the primary and secondary return flows. The connection to the pump is made via the two analogue inputs. An immersion temperature sensor with suitable immersion sleeves is described in the “Accessories” chapter.

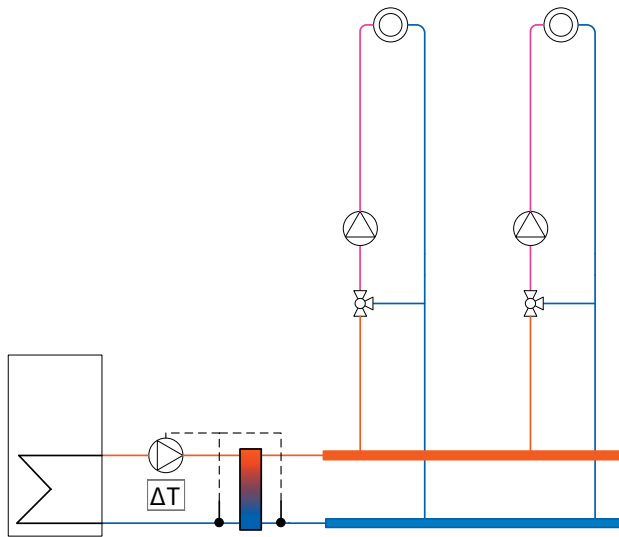

Temperature control ΔT -const of feeder pump via hydraulic shunt

Multi-Flow Adaptation

With the Multi-Flow Adaptation control mode, the volume flow in the generator/feeder circuit (primary circuit) is aligned with the volume flow in the consumer circuits (secondary circuit). Multi-Flow Adaptation is set in the Stratos MAXO feeder pump in the primary circuit upstream of the hydraulic shunt. The Stratos MAXO feeder pump is connected to the Stratos MAXO pumps in the secondary circuits via a data cable. The feeder pump continuously receives the respective required volume flow from each individual secondary pump in short intervals. The sum of the required volume flows from all secondary pumps is set by the feeder pump as the target volume flow. On commissioning, all associated secondary pumps must be connected to the primary pump so that it can take their volume flows into consideration. A fixed volume flow requirement can be entered for non-communication-capable secondary pumps so that their flows are also taken into consideration.

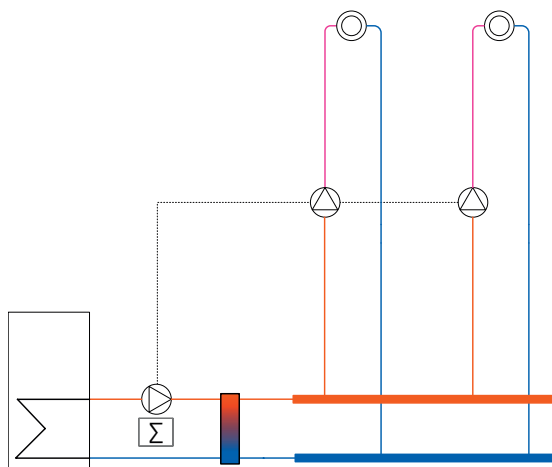

Multi-Flow Adaptation of feeder pump via hydraulic shunt with secondary pumps in the line without mixer

4.1.8 Cooling: Ceiling cooling consumer circuit

The pump is installed in a consumer circuit that supplies fast surface cooling, e.g. a cooling ceiling or ceiling canopy. The control modes Δp -c, Dynamic Adapt plus or T-const constant hall temperature can be used for this application.

Pressure control

If the cooling circuit supplies multiple rooms, the cooling area circuits will be fitted with control valves to regulate the individual rooms' temperatures. In this case, Δp -c (nominal delivery head setting required) or Dynamic Adapt plus (nominal delivery head setting not required) could be selected. For this application, Wilo recommends the Dynamic Adapt plus control mode.

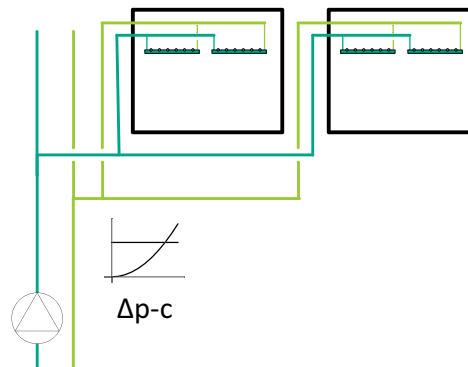

Pressure control in a ceiling cooling consumer circuit

Hall temperature control modes

If the cooling circuit cools a large thermal zone, e.g. a hall, the control valves on the ceiling cooling's distributor connections are redundant and are often not present in existing buildings. The pump can then directly regulate the hall temperature to the desired setpoint using the T-const constant hall temperature control mode. In addition, it is necessary to install a temperature sensor or a room user interface in the hall to measure the temperature and act as a setpoint controller. These values are transmitted to the pump via the analogue inputs. The temperature sensor to measure the actual temperature can either be connected directly as a PT1000 sensor or as an active sensor with 0...10 V and 4...20 mA. The setpoint can be transmitted as a 0...10 V or 4...20 mA signal. If a setpoint controller is not installed in the room, the setpoint can also be set in the pump as a fixed value.

Further information on room user interfaces can be found in the "Accessories" chapter.

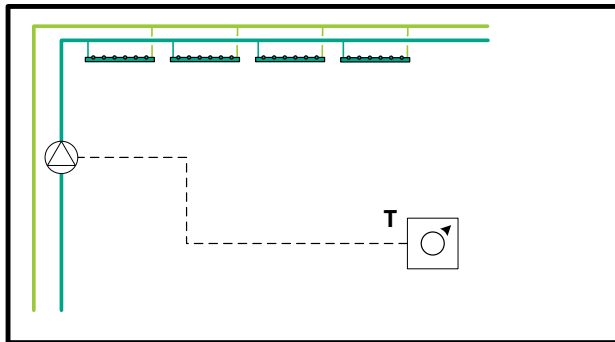

Hall temperature control in a ceiling cooling consumer circuit

4.1.9 Cooling: Underfloor cooling consumer circuit

The pump is installed in a consumer circuit that supplies slow surface cooling, e.g. underfloor cooling. The control modes $\Delta p-c$, Dynamic Adapt plus or T-const constant hall temperature can be used for this application.

Pressure control

If the cooling circuit supplies multiple rooms, the cooling area circuits will be fitted with control valves to regulate the individual rooms' temperatures. In this case, $\Delta p-c$ (nominal delivery head setting required) or Dynamic Adapt plus (nominal delivery head setting not required) could be selected. For this application, Wilo recommends the Dynamic Adapt plus control mode.

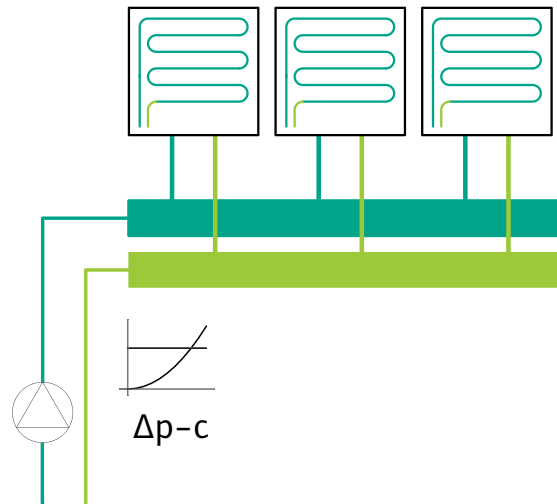

Pressure control in an underfloor cooling consumer circuit

Hall temperature control modes

If the cooling circuit cools a large thermal zone, e.g. a hall, the control valves on the underfloor cooling's distributor connections are redundant and are often not present in existing buildings. The pump can then directly regulate the hall temperature to the desired setpoint using the T-const constant hall temperature control mode. In addition, it is necessary to install a temperature sensor or a room user interface in the hall to measure the temperature and act as a setpoint controller. These values are transmitted to the pump via the analogue inputs. The temperature sensor to measure the actual temperature can either be connected directly as a PT1000 sensor or as an active sensor with 0...10 V and 4...20 mA. The setpoint can be transmitted as a 0...10 V or 4...20 mA signal. If a setpoint controller is not installed in the room, the setpoint can also be set in the pump as a fixed value.

The "Accessories" chapter contains details of a suitable room user interface.

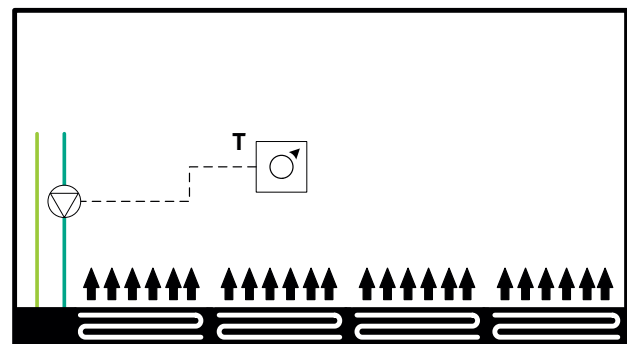

Hall temperature control in an underfloor cooling consumer circuit

4.1.10 Cooling: Air-conditioning device consumer circuit

The pump is installed in a consumer circuit that supplies very fast air cooling, e.g. an air-conditioning device. The control modes Δp -v, Dynamic Adapt plus or T-const constant hall temperature can be used for this application.

Pressure control

If the cooling circuit supplies multiple rooms, the air-conditioning device will be fitted with control valves to regulate the individual rooms' temperatures. In this case, Δp -v (nominal delivery head setting required) or Dynamic Adapt plus (nominal delivery head setting not required) could be selected. For this application, Wilo recommends the Dynamic Adapt plus control mode.

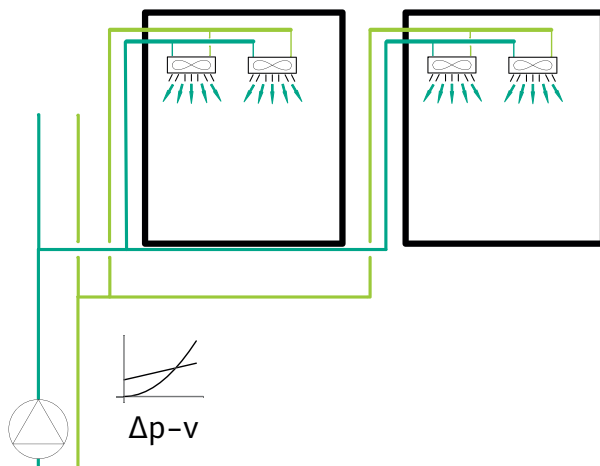

Pressure control in an air-conditioning device consumer circuit

Hall temperature control modes

If the cooling circuit cools a large thermal zone, e.g. a hall, the control valves on the air-conditioning devices are redundant and are often not present in existing buildings. The pump can then directly regulate the hall temperature to the desired setpoint using the T-const constant hall temperature control mode. In addition, it is necessary to install a temperature sensor or a room user interface in the hall to measure the temperature and act as a setpoint controller. These values are transmitted to the pump via the analogue inputs. The temperature sensor to measure the actual temperature can either be connected directly as a PT1000 sensor or as an active sensor with 0...10 V and 4...20 mA. The setpoint can be transmitted as a 0...10 V or 4...20 mA signal. If a setpoint controller is not installed in the room, the setpoint can also be set in the pump as a fixed value.

The "Accessories" chapter contains details of a suitable room user interface.

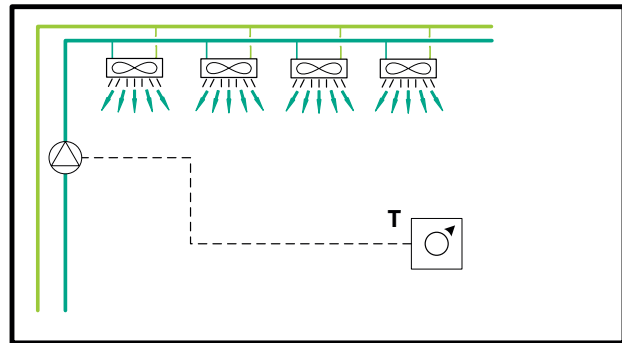

Hall temperature control in an air conditioning device consumer circuit

4.1.11 Cooling: Generator or feeder circuit with heat exchanger

See Chapter 4.1.6: Heating: Generator or feeder circuit with heat exchanger

4.1.12 Cooling: Generator or feeder circuit with hydraulic shunt

See Chapter 4.1.7: Heating: Generator or feeder circuit with hydraulic shunt

4.1.13 Drinking water: Circulation

The pump is installed as a circulator. The T-const control mode can be used for this application in order to enable safe, hygienic operation.

Temperature control

The pump in the circulation line changes its speed so that the water returning to the tank is always at the desired specified warm water temperature. The temperature sensor for this purpose is located in the pump. A separate sensor is not necessary.

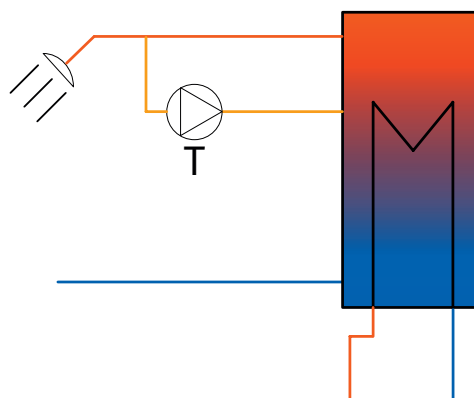

Temperature control of the domestic hot water circulator

4.2 Basic control modes

In addition to the option of selecting the control mode based on the application, the basic control modes can also be directly adjusted. This is the case, for example, when the required settings for the field of application are already known (e.g. in the case of pump replacement) or if none of the pump's predefined applications are suitable for the specific installation.

The basic control modes are freely configurable and can be individually adjusted to the application by the user. They can also be combined with numerous additional options. In this case, it must be checked that the pump functions correctly.

Wilo recommends using the application-based control mode settings. These have been configured and optimised for the respective application.

The following control modes are available in the Stratos MAXO.

- Differential pressure $\Delta p-c$
- Index circuit $\Delta p-c$
- Differential pressure $\Delta p-v$
- Dynamic Adapt plus
- Temperature T -const
- Temperature ΔT -const
- Volume flow Q -const
- Multi-Flow Adaptation
- Speed n -const
- PID control

4.2.1 Differential pressure $\Delta p-c$

In $\Delta p-c$ control mode, the pump keeps the differential pressure it generates constant at the set differential pressure setpoint H_{setpoint} throughout the permissible volume flow range up to the maximum pump curve. The required differential pressure from the pipe network calculation H_n corresponds to the setpoint H_{setpoint} .

Control properties:

Sufficient supply is ensured, including for non-balanced hydraulic networks. The nominal delivery head must be specified. Noises may be heard if the delivery head is set too high.

Fields of application e.g.:

- Consumer circuit with underfloor heating (heating) or underfloor/ceiling vents (cooling) in which pressure fluctuations through valves are very low compared to the pressure loss in the pipe network

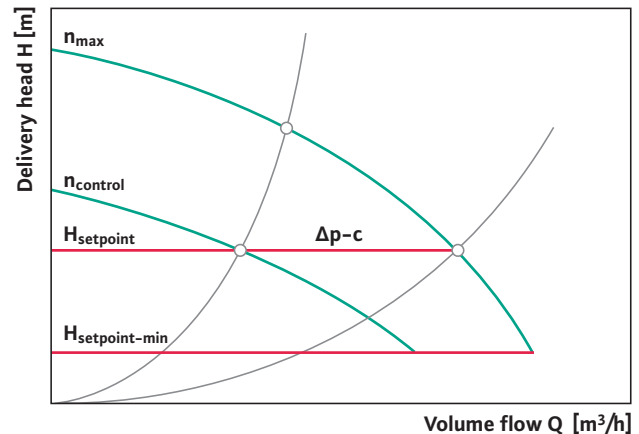

4.2.2 Index circuit $\Delta p-c$

In the index circuit $\Delta p-c$ control mode, the pump keeps the differential pressure at a remote point in the pipe network (index circuit) constant at the set differential pressure setpoint H_s throughout the permissible volume flow range up to the maximum pump curve. The required differential pressure from the pipe network calculation H_n corresponds to the setpoint H_s .

A differential pressure sensor is installed at the index circuit and connected to the pump as an actual value sensor via an analogue input.

The nominal differential pressure to be maintained at the index circuit must be specified.

Control properties:

Just as for $\Delta p-c$, the nominal delivery head must be specified that applies precisely to the remote point in the network. An index circuit evaluation continuously monitors the sensor's pressure difference at the critical point in the pipe network.

Fields of application e.g.:

- Primary side of a local heat supply up to the transfer station to the connected buildings
- Extensive existing systems with unknown hydraulic properties

4.2.3 Differential pressure $\Delta p-v$

In the $\Delta p-v$ control mode, the pump linearly varies the differential pressure setpoint to be maintained between the specified H_{setpoint} on the maximum pump curve and $\frac{1}{2} H_{\text{setpoint}}$ at zero volume flow. The setpoint H_{setpoint} does not generally correspond to the required differential pressure from the pipe network calculation, and must instead be identified using the nominal duty point and Q_{nominal} . The duty point (nominal volume flow and delivery head) can be directly specified using the additional "Nominal duty point" function.

Control properties:

The pump variably adjusts the required volume flow according to the opened and closed valves on the consumers, thereby adjusting the power required. It saves electrical pumping energy in comparison to Δp -c. The setpoint is defined using the duty point, which can usually be taken from the pipe network calculation.

Fields of application e.g.:

→ Consumer circuit with radiators and fan heaters (heating) or air-conditioning devices (cooling)

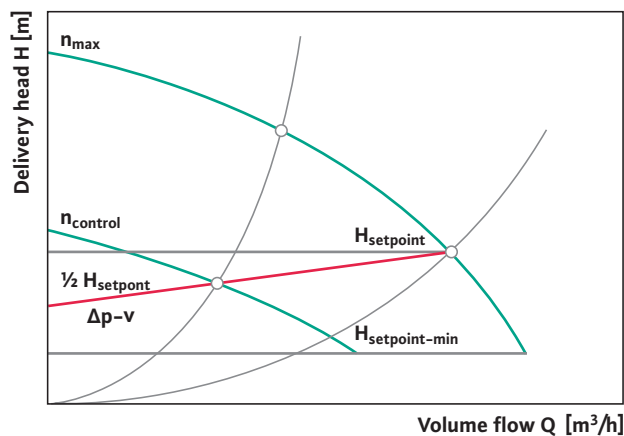
**4.2.4 Dynamic Adapt plus**

The pump automatically adjusts the delivery head to the hydraulic demand without the need to specify a setpoint. After initial commissioning, the pump selects a duty point in the middle of the pump duty chart. New operating points are identified after each change in volume flow. The aim of this control method is to select the operating point so that the valves are open as wide as possible. This allows the system to operate with the lowest possible pressure loss.

Control properties:

The delivery head does not need to be specified. The pump automatically and independently adapts to variable pressure conditions. Electrical pumping energy savings of up to 20 % are possible in comparison to Δp -v. The performance range extends across almost the entire pump duty chart.

Fields of application e.g.:

→ Consumer circuits with variable volume flows, e.g. radiators with thermostatic valves, underfloor heating with individual room controls, cooling ceilings or air-conditioning devices

4.2.5 Temperature T-const

In the T-const control mode, the pump keeps the temperature constant at a specified setpoint. In the positive effective direction, the pump increases its speed if the actual temperature is lower than the setpoint temperature. In the negative effective direction, speed decreases. The effective direction and the controller's amplification factors can be individually adjusted by selecting the basic control mode without selecting the application. A temperature sensor is installed to transmit the current temperature e.g. in the feed to the secondary circuit. These values are transmitted to the pump via the analogue inputs. The temperature sensor can either be connected directly as a PT1000 sensor or as an active sensor with 0...10 V and 4...20 mA.

Control properties:

Independent of the differential pressure, the pump provides the exact volume flow required to maintain the specified setpoint temperature.

Fields of application e.g.:

→ Supply of a consumer circuit with a fixed feed temperature

An immersion temperature sensor with suitable immersion sleeves is described in the "Accessories" chapter.

4.2.6 Temperature ΔT -const

In the ΔT const control mode, the pump maintains a constant temperature difference setpoint. In the positive effective direction, the pump increases its speed if the actual temperature difference is higher than the setpoint temperature difference. In the negative effective direction, speed decreases. The effective direction and the controller's amplification factors can be individually adjusted by selecting the basic control mode without selecting the application. Two temperature sensors are installed to transmit the current temperature e.g. in the primary and secondary circuit feeds. These values are transmitted to the pump via the analogue inputs. The temperature sensors can either be connected directly as PT1000 sensors or as active sensors with 0...10 V and 4...20 mA.

Control properties:

Independent of the differential pressure, the pump provides the exact volume flow required to maintain the specified setpoint temperature difference.

Fields of application e.g.:

→ Supply of a consumer circuit with a fixed temperature difference

An immersion temperature sensor with suitable immersion sleeves is described in the "Accessories" chapter.

4.2.7 Volume flow Q-const

In the Q-const constant volume flow control mode, the pump keeps constant at the specified volume flow setpoint. For this purpose, the speed increases within the permitted range if the measured volume flow is less than the setpoint, and vice versa.

Control properties:

The desired volume flow is kept constant, independent of the differential pressure.

Fields of application e.g.:

- Generator circuit of a heat pump without a controlled inverter to maintain strict heat output
- Storage charging with storage charge pump
- Cooling circuit with cooling tower with constant power

4.2.8 Multi-Flow Adaptation

The Multi-Flow Adaptation control mode is applicable for a Stratos MAXO feeder pump in the primary circuit that, for example, supplies an open distributor, a hydraulic shunt or a heat exchanger. The feeder pump is connected to the Stratos MAXO pumps in the secondary circuits via a data cable. The feeder pump continuously receives the respective required volume flow from each individual secondary pump in short intervals. The sum of the required volume flows from all secondary pumps is set by the feeder pump as the target volume flow. On commissioning, all associated secondary pumps must be connected to the primary pump so that it can take their volume flows into consideration. A fixed volume flow value can be entered for non-communication-capable secondary pumps.

Control properties:

The feeder pump provides exactly as much volume flow as is required by the secondary pumps. It therefore saves electrical pumping energy in comparison to Δp -c control. The heat generator's degree of utilisation is optimised by a lower return temperature. This leads to fuel savings. For local and district heating transfer stations, the lower return temperature leads to higher operational reliability, as it avoids activating the return temperature limiter as well as overflows.

Field of application e.g.:

- Pumps in district heating transfer stations without controllers that supply distributors with secondary pumps
- Feeder pumps that supply open distributors or heat exchangers with secondary pumps with no speed control through the heat generator

4.2.9 Speed n-const

In the constant speed n control mode, the pump control keeps constant at the specified speed setpoint.

Control properties:

The speed setpoint is usually specified via an external signal, e.g. via 0 – 10 V. The setpoint always remains the same unless changed based on demand.

Field of application e.g.:

- Control of the Stratos MAXO by a boiler controller via the 0 – 10 V signal.

4.2.10 PID control

In the PID control mode, the pump keeps constant at a defined setpoint by means of a PID controller. This setpoint could be a temperature, a pressure or any other physical value. A signal value transmitted via one of the pump's analogue inputs can be used as the actual value. The effective direction of the controller and its amplification factors P, I and D can be individually adjusted according to the application.

Control properties:

The pump's P, I and D factors are set on the basis of individual, specific requirements. Advanced knowledge of control technology is required to make configurations.

Field of application e.g.:

- Fill level control for a boiler's feeding pump

4.3 Additional functions for the control modes

4.3.1 No-Flow Stop

The pump recognises when, despite its speed, the flow rate supplied is too low. This means that the valves in the consumer circuit are closed.

The pump stops the motor if the volume flow falls below a specified minimum level. The pump then checks at regular intervals whether the minimum volume flow has been exceeded again. As soon as this occurs, the pump continues in its set control mode in auto control mode.

Benefit:

Electrical pumping energy is saved by avoiding unnecessary running times.

Field of application e.g.:

- A pump in a consumer circuit with radiators, fan heaters, underfloor or ceiling vents in heating or cooling mode, as an additional function for all control modes except Multi-Flow Adaptation

4.3.2 Automatic detection of setback operation

The pump detects a significant reduction in fluid temperature over a defined period of time. The pump thereby deduces that the heat generator is in setback operation. The pump independently reduces its speed until a high fluid temperature is once again detected over a longer period of time. This leads to savings in electrical pumping energy.

Benefit:

Electrical pumping energy is saved by avoiding unnecessary running times.

Field of application e.g.:

- A pump in a heat generator circuit in control modes $\Delta p-v$ or $\Delta p-c$ supplying a system with radiators or fan heaters
- A pump in heat generator circuits in control mode $T-\text{const}$ or $\Delta T-\text{const}$
- A pump in a consumer circuit with radiators or fan heaters in control modes Dynamic Adapt plus or $\Delta p-v$

4.3.3 Nominal duty point in $\Delta p-v$ control

The additional function of a nominal duty point can be used together with $\Delta p-v$. Instead of the delivery head on the maximum pump curve, the nominal duty point can be entered directly. This is made up of the nominal volume flow and the nominal delivery head. Both values can usually be taken from the pipe network calculation and are often provided on the heating or cooling schematics in the pump list. Pump control automatically calculates a suitable pump curve that runs through the nominal duty point.

Benefit:

If known, the desired duty point can be precisely specified.

Field of application e.g.:

- A pump in a consumer circuit with radiators or fan heaters in control mode $\Delta p-v$

4.3.4 Q-Limit Min (minimum volume flow limit)

The Q-Limit Min function can be used in conjunction with all control modes except Dynamic Adapt plus and constant volume flow $Q-\text{const}$. The pump will not fall below the specified minimum volume flow limit within the permitted range, independent of the delivery head.

Benefit:

Pump is adjusted precisely according to demand

Field of application e.g.:

- Ensuring the minimum volume of circulation water in a heat generator

4.3.5 Q-Limit Max (maximum volume flow limit)

The Q-Limit Max function can be used in conjunction with all control modes except Dynamic Adapt plus and constant volume flow $Q-\text{const}$. The specified maximum volume flow limit is not exceeded by the pump control within the permitted range, independent of the delivery head.

Benefit:

Pump is adjusted precisely according to demand. Additional components such as differential pressure valves or mixers are not required.

Field of application e.g.:

- A pump in a heat generator circuit and a storage charge pump: Limit the maximum volume flow to boiler output in the event of low pipeline resistance
- Local/district heating: Limit the maximum volume flow of the pump on the secondary side because the maximum permitted volume flow is available on the primary side (supply side). (Return temperature is thereby kept low)

4.3.6 Switching between heating/cooling

If the Stratos MAXO is installed in a circuit used for both heating and cooling, the pump can switch between heating or cooling depending on the current application. This is achieved by an external binary contact, through a building automation data item or by detecting the feed temperature. If the feed temperature is over e.g. 25 °C, the pump enters heating mode with the corresponding control mode setting (e.g. Dynamic Adapt plus). If the feed temperature is below e.g. 19 °C, it operates in the applicable setting (e.g. $\Delta p-c$). Between 19 °C and 25 °C, the pump starts up at regular intervals to identify whether cooling or heating is required. 19 °C and 25 °C are the preconfigured values, but other settings can be made.

Benefit:

The pump is individually adjusted to ensure optimal energy transfer in heating or cooling mode. The pump itself identifies the current application.

The heating/cooling quantity required from the pump is identified separately.

Fields of application e.g.:

- A heat generator pump downstream of a three-way valve that supplies a cold water generator and a heat generator
- A pump in the consumer circuit of a reversible heat pump that both heats and cools
- A consumer rotary pump that supplies both hot and cold water for e.g. concrete core activation or ceiling vents

4.3.7 Detection of thermal disinfection

The domestic hot water circulator uses a sensor connected to the hot water tank or the hot water output line to detect when the hot water temperature exceeds a specified limit value. It detects that thermal disinfection has been started and thus continues to supply at full speed. A pipe surface contact sensor mounted on the hot water discharge line must also be connected to the pump.

Benefit:

Reduction of rapid cooling of hot water in the pipe network and improvement of the thermal disinfection effect by ensuring proper flushing using a high volume flow.

Fields of application e.g.:

- Domestic hot water circulator in hot water systems in which regular thermal disinfection is required

A pipe contact temperature sensor is described in the “Accessories” chapter.

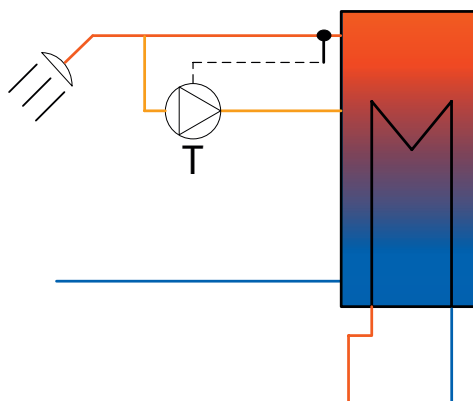

Temperature control of the domestic hot water circulator with detection of thermal disinfection

4.4 Data collection functions of the Stratos MAXO

4.4.1 Heating/cooling quantity measurement

The heating/cooling quantity is measured through volume flow detection in the pump and temperature detection in the feed or return. The Stratos MAXO has a precise fluid temperature sensor which can detect one of the two temperatures (depending on whether the pump is installed in the feed or return). As a result, only one further temperature sensor is required and should be connected to the pump.

An application-based pump configuration must be conducted for heating and cooling respectively. The pump can switch over to heating or cooling either automatically or as instructed by an external signal. The heating and cooling quantity is identified separately based on the application.

Benefit:

An energy measurement for heating and cooling can be conducted without an additional energy meter. The measurement can be used for the internal distribution of heating and cooling costs or for system monitoring. However, as the heating and cooling measurement is not calibrated, it cannot be used as the basis for billing.

Fields of application e.g.:

- Internal billing of energy flows
- System and energy monitoring
- System optimisation

An immersion temperature sensor with suitable immersion sleeves is described in the “Accessories” chapter.

4.5 Pump functions independent of the control mode

4.5.1 Double pump management

The Stratos MAXO can be operated either with two single pumps or as a double pump variant with double pump management.

The double pump variant is fully wired-up upon delivery and is configured as a double pump. Only one of the two pump modules has a fully functional LCD colour display. The second pump module is equipped with a 7-segment LED display.

If two single pumps in the Y-piece are operated as a double pump, both single pumps must be set to double pump mode on commissioning. Cabling between the pumps for double pump operation must also be completed during installation and commissioning.

The following operating modes are possible due to the intelligent double pump management system with one Stratos MAXO-D double pump or two Stratos MAXO single pumps:

Main/standby operation

If the version-specific pump output is provided by one pump, the other pump remains available on standby for time-actuated switchover (24 hours of pure operating time) or fault-actuated switchover. Standby operation can be performed by all double pumps and all single pumps (2 x identical type).

Parallel operation

If the version-specific pump output is provided by both pumps in parallel operation, power adjustments are made through synchronous operation of both pumps. Parallel operation can be performed by all double pumps and all single pumps (2 x identical type).

4.5.2 Automatic venting of the pump

The Stratos MAXO is capable of automatic venting. The automatic pump venting function can be started while putting the pump into operation. This vents the pump hydraulics. All further pump adjustments can be made in parallel.

Venting of the entire distribution and consumer network must occur via the corresponding vent plugs.

4.5.3 Pump kick

In order to avoid impeller blockages when the pump is not operating for longer periods (e.g. an inactive heating system during summer), the pump regularly performs a pump kick by briefly starting it. If the pump has no operational running time within a period of 24 hours, the pump kick is activated. The pump must have a constant voltage supply in order to carry out this function. The function's time interval can be adjusted on the pump.

4.6 Stratos MAXO accessories

In accordance with the application, its incorporation in other systems or the installation location, the following corresponding accessory components may be required:

- Thermal insulation for heating and domestic hot water circulation applications
- Diffusion-proof insulation for cold water application when cooling
- PT 1000 AA immersion temperature sensor for heating/cooling
- PT 1000 B pipe surface contact sensor to detect thermal disinfection in domestic hot water circulation
- Room user interface to regulate by hall temperature
- CIF modules to connect to building automation via bus protocols

4.6.1 Thermal insulation for heating and domestic hot water circulation applications

The Stratos MAXO single pump variants are equipped as standard with a thermal insulation shell for the prevention of heat losses through the pump housing. These are included in the Stratos MAXO on delivery and do not need to be ordered separately. This thermal insulation shell should only be installed for fluid temperatures > 20 °C.

The insulating material used has the following properties:

- Environmental compatibility: easy to recycle
- Thermal resistance: up to 120 °C
- Heat transmission coefficient: 0.04 W/mK in accordance with DIN 52612
- Flammability: Class B2 in accordance with DIN 4102 (normal flammability)

Materials that are normally flammable are permitted for use in heated rooms in Germany in accordance with fire prevention ordinances as long as a minimum clearance of 20 cm is maintained between them and the fireplace.

4.6.2 Diffusion-proof insulation for cold water application when cooling

If the pump housing of the Stratos MAXO is given diffusion-proof insulation on-site for cold water application with fluid temperature < 20 °C, the insulation may not cover the drain labyrinth between pump housing and motor. That ensures that any condensate that has possibly accumulated in the motor can drain off freely through the condensate drain openings in the motor housing.

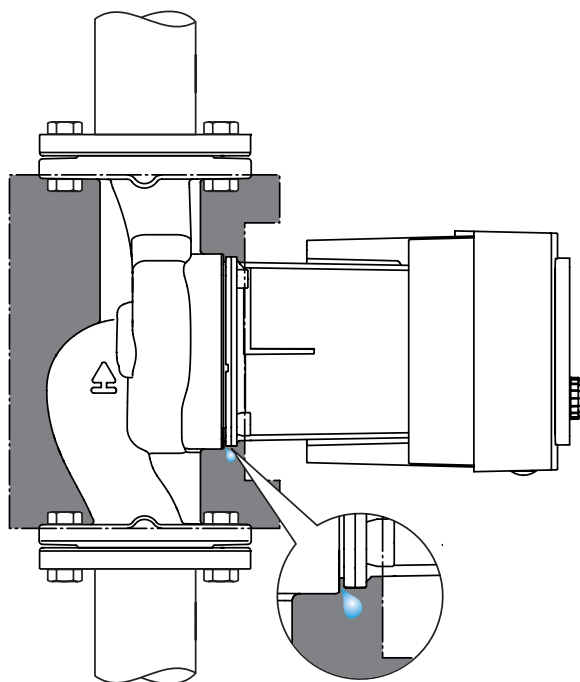

Condensate drain opening in the motor housing

4.6.3 PT 1000 AA immersion temperature sensor for heating/cooling with immersion sleeve

Temperature sensor PT 1000 AA for installation in an immersion sleeve is available for heating and cooling applications.

The connection to the Stratos MAXO to detect the fluid temperature in the case of temperature-dependent pump control or to detect heating/cooling quantities is made using the AI 1 or AI 2 analogue inputs, which can be adjusted to accommodate connection type PT 1000.

Technical data:

Tolerance class AA in accordance with DIN EN 60751

Cable length 3 m

In order to install the immersion temperature sensor in the piping, immersion sleeves are available in two lengths as accessories:

- Immersion sleeve with length of engagement 45 mm for pipe diameter of DN 25 to approx. DN 50.
- Immersion sleeve with length of engagement 100 mm for pipe diameter of DN 65 to approx. DN 100

Technical data:

- Pipe connection G ½ with width across flats AF 21
- PG 7 clamping ring screw connection with width across flats AF 13 to fix the temperature sensor in the immersion sleeve
- Outer diameter of the measurement pipes 8 mm

4.6.4 PT 1000 B pipe surface contact sensor to detect thermal disinfection

When used for domestic hot water circulation, the Stratos MAXO-Z can detect when heating starts in the hot water tank for thermal disinfection purposes. To achieve this, a temperature sensor must be attached to the pipe at the tank's hot water outlet. An immersion temperature sensor is not necessary.

The connection to the Stratos MAXO to detect the hot water outlet temperature is made using the AI 1 or AI 2 analogue inputs, which can be adjusted to accommodate connection type PT 1000.

Technical data:

Tolerance class B in accordance with DIN EN 60751

Cable length 5 m

4.6.5 Room user interface for T-const hall temperature control

For the Stratos MAXO's T-const hall temperature control mode, a room user interface can be connected to the pump to transmit the actual temperature value as PT 1000 or as a 0...10 V signal.

Wilo does not offer a room user interface of its own that can be used to set the required temperature in the hall. The following commercially available room user interfaces are examples of models that can be used for this purpose:

- User interfaces in the WRF series produced by Thermokon with 0 – 10 V signal (e.g. WRF04 P TRV3, active potentiometer, item no. 208864)
- User interface produced by Oventrop (accessory for Regtronic RH) with PT 1000 (Item no. 1152096)

The room user interface is connected to the Stratos MAXO using the AI 1 or AI 2 analogue inputs, which can be adjusted to accommodate connection type PT 1000 or 0 – 10 V. When using the 0 – 10 V connection type, the transfer curve must be adjusted to the sensor's measurement range if necessary.

4.6.6 Differential pressure sensor for the Δp -c index circuit evaluator

A differential pressure sensor is connected to the Stratos MAXO in order to facilitate the Δp -c index circuit evaluator. The distance between Stratos MAXO and the least hydraulically favourable location in the pipe network, where the desired differential pressure should be maintained, is usually considerable. Differential pressure sensors with the 4 – 20 mA signal are therefore recommended.

The differential pressure sensor is connected to the Stratos MAXO using the AI 1 or AI 2 analogue inputs, which can be adjusted to accommodate the 4 – 20 mA signal.

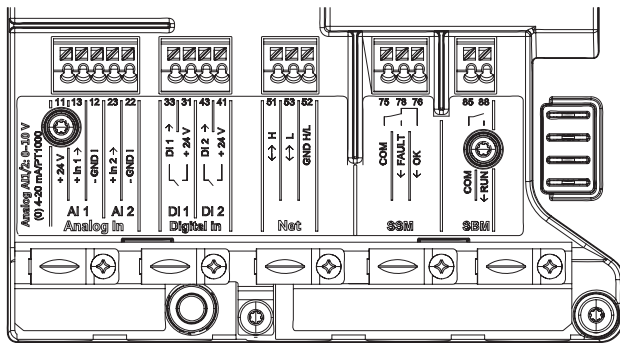

Terminal room of the Stratos MAXO

4.6.7 CIF module for BUS connection to building automation

The required, retrofittable interface model is used for the connection to building automation via a BUS protocol. The CIF modules listed in the table are available for various BUS protocols:

5 Installation

5.1 Hydraulic installation

5.1.1 Pipe installation

Screw-end pumps

Stratos MAXO screw-end pumps are equipped with connecting threads in G 1 ½ or G 2 depending on their size, according to DIN EN ISO 228 Part 1.

Gaskets are included in the scope of delivery.

Threaded pipe unions with pipe thread in accordance with DIN EN 10226-1 must be ordered separately. The following screwed connections are available for Stratos MAXO screw-end pumps for use in heating or cooling applications:

Screwed connections with union inserts with female threads to connect to threaded pipes with Whitworth pipe thread DIN EN 10226-1 (pipe thread sealing in the thread)

→ Rp 1 x G 1 ½

→ Rp 1 ¼ x G 2

Threaded adapters, Wilo-R

For the length compensation of pipe adaptors, Wilo-R threaded adaptor pieces are available in various lengths and in thread sizes G 1 ½ and G 2 on the pump side and R 1 ½, R 2 and R 2 ¼ on the piping side.

For Stratos MAXO-Z screw-end pumps

Brass screwed connections are available for Stratos MAXO-Z in domestic hot water circulation. Connection male thread R 1 and R 1 ¼ to the piping, pump connection in G 1 ½ and G 2. See catalogue for details.

Wilo-R threaded adaptors for domestic hot water screw-end pumps

For the length compensation of pipe adaptors, Wilo-R brass threaded adaptors are available in various lengths. Thread sizes G 1 ½ and G 2 on the pump side as well as R 2 and R 2 ¼ on the piping side. See catalogue for details.

Flange-end pumps

Stratos MAXO flange-end pumps are configured in DN 32 to DN 100.

The standard version in nominal sizes DN 32 to DN 65 have combination flanges in PN 6/10.

CIF module types	BACnet	CANopen	LON	Modbus RTU	PLR
Line type	Bus cable, twisted in pairs, braided shield, 120 Ω characteristic impedance	CAN bus cable, twisted in pairs, shielded, 1 x 2 x 0.5 mm ² / 120 Ω characteristic impedance (line type B in accordance with TIA 485-A)	Twisted in pairs, shielded	Bus cable, twisted in pairs, braided shield, 120 Ω characteristic impedance	Twisted in pairs, shielded
Line length	1000 m	200 m	900 m (bus topology with max. 3 m spur line); 500 m (free topology, max. 250 m between communicating consumers)	1000 m	200 m
Spur line	Not permitted	Max. 10 m, max. total 50 m	See line length	Not permitted	Not permitted
Terminal cross-section	1.5 mm ²	1.5 mm ²	1.5 mm ²	1.5 mm ²	1.5 mm ²
Interface	RS485 (TIA-485A), insulated	CAN in accordance with ISO 11898-2, insulated	TP/FT 10	RS485 (TIA-485A), insulated	Wilo specific, insulated
Speed	9600, 19200, 38400, 76800 kBit/	125 kBit/s, constant	78 kBit/s, constant	2400, 9600, 19200, 38400, 115200 kBit/s	Solid
Format	Solid	-	-	-8 data bits, -no/even/uneven parity -1/2 stop bits (2 only without parity)	-
Protocol	BACnet MS/TP Version 1 Revision 4	CANopen in accordance with CiA DS301 V 4.02	LonMark Layers 1 – 6 Interoperability Guidelines 3.2;	Modbus RTU	PLR
Profile	BACnet Smart Sensor, Smart Actuator (B SS, B SA)	-	Pump Controller: 8120	-	-
Data items as control commands to the pump	<ul style="list-style-type: none"> → Setpoints for control modes Δp-v, Δp-c, n-const → Pump On/Off → Setback operation 				
Data items as a signal from the pump	<ul style="list-style-type: none"> → Actual delivery head value → Actual speed value → Actual volume flow value → Actual electricity consumption value → Actual electrical power value → Operating hours → Detailed error and status signals 				
For exact data items see data item description of the respective bus system (www.wilo.com/automation)					

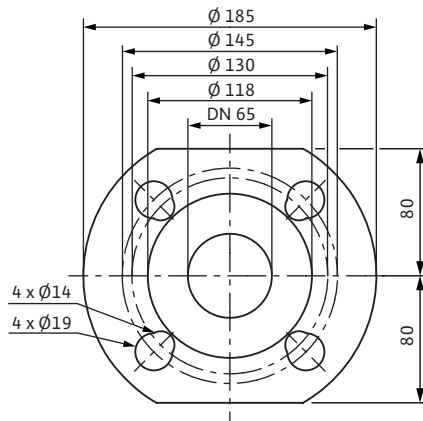

Example combination flange PN 6/10 for DN 65

In nominal sizes DN 80 and DN 100, the flange standard versions PN 6 and PN 10 are available.

Special versions of pumps DN 32 to DN 100 are also available in PN 16.

Detailed specifications can be found under the Stratos MAXO series in the catalogue.

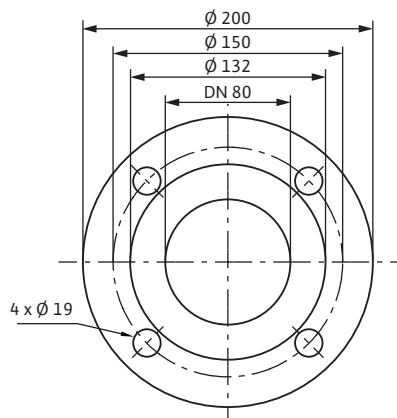

Flange PN 6 for DN 80

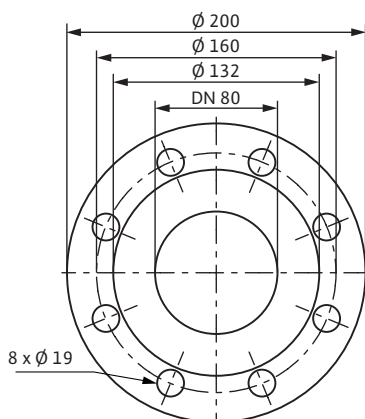

Flange PN 10 for DN 80

Combination flange pumps

Flange-end pumps with combination flanges can be mounted with counter flanges PN 6 and PN 16 in accordance with DIN or DIN EN up to and including DN 65. The installation of a combination flange with a combination flange is not permitted. Screws with a strength class of 4.6 or higher are to be used for the flange connections. The washers included in the scope of delivery must be installed between the screw/nut head and the combination flange.

Flanged rings Wilo-RF

The Wilo-RF flanged rings are – a few exceptions aside – intended for length compensation with PN 6 flanges. Piping has to be changed for length compensation with PN 10/16 flanges. Flanged rings on the pump side are available in G 1 ½ and G 2, while connections on the piping side are from DN 25 to DN 50. See catalogue for details.

Flange-end pumps PN 6

	DN 32	DN 40	DN 50
Screw diameter		M12	
Strength class		≥ 4.6	
Tightening torque		40 Nm	
Screw length	≥ 55 mm	≥ 60 mm	

	DN 65	DN 80	DN 100
Screw diameter		M16	
Strength class		≥ 4.6	
Tightening torque		95 Nm	
Screw length	≥ 60 mm	≥ 70 mm	

Flange-end pumps PN 10 and PN 16

	DN 32	DN 40	DN 50
Screw diameter		M16	
Strength class		≥ 4.6	
Tightening torque		95 Nm	
Screw length	≥ 60 mm	≥ 65 mm	

	DN 65	DN 80	DN 100
Screw diameter		M16	
Strength class		≥ 4.6	
Tightening torque	95 Nm	95 Nm	
Screw length	≥ 65 mm	≥ 70 mm	

Installation in the feed of open systems

Branch off the safety feed ahead of the pump when installing in feed of open systems (EN 12828).

5.1.2 Permitted installation positions

The Stratos MAXO can be installed in the positions listed below.

Impermissible positions are also shown.

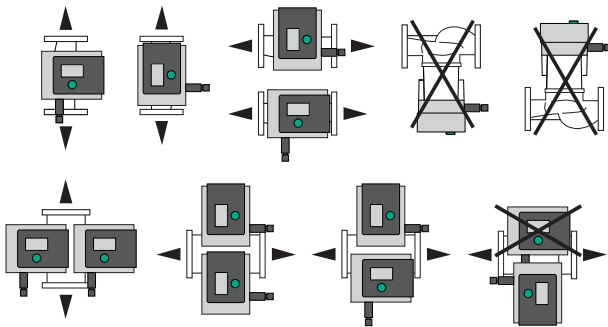

5.1.3 Installation dimensions of the Stratos MAXO

The pump dimensions must be considered when installing the Stratos MAXO with distributors and in piping systems, so that the clearances around distribution outlets and with surrounding components are taken into account. The dimensions of all Stratos MAXO variants are detailed in the catalogue.

5.2 Electrical connections and interfaces

The Stratos MAXO has a clearly-arranged terminal room, which is located behind the large display. The display is easily removed, enabling access to the terminal room. It contains all electrical cabling connections.

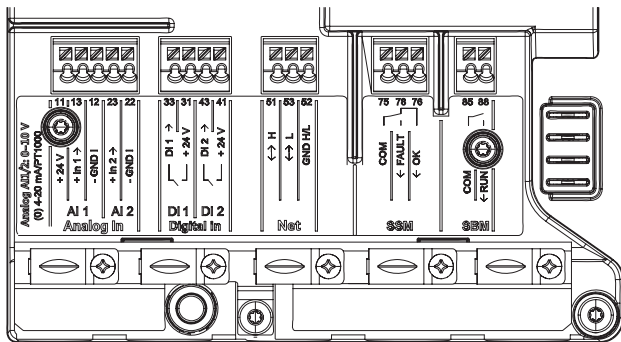

Terminal room of the Stratos MAXO

5.2.1 Electrical mains connection

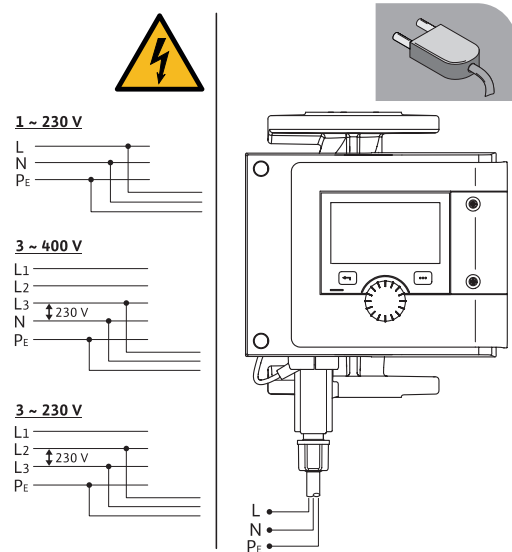

The pump can be connected to power supplies with the following voltage ratings:

- 1~ 230 V
- 3~ 400 V with neutral conductor
- 3~ 230 V
- 3~ 400 V without neutral conductor (upstream mains transformer)

- The minimum back-up fuse must be 16 A, slow-blow or a circuit breaker with C characteristic.
 - For double pumps, both motors must be separately connected and safeguarded.
 - Never connect to an uninterruptible power supply or IT networks.
 - A pulsing of the power supply (e.g. phase angle control) is not permissible! A pulse power supply must be deactivated.
 - Switching the pump via triacs/solid-state relays must be examined on a case-by-case basis.
 - During deactivation with on-site power relay: Rated current ≥ 10 A, rated voltage 250 V AC
 - The switching frequency must be taken into account:
 - Switching on/off mains voltage $\leq 100/24$ h
 - Switch-on/off procedures via Ext. Off, 0 – 10 V, or via bus communication $\leq 20/h$ ($\leq 480/24$ h)
 - For the electrical fuse protection of the Stratos MAXO, the local legal installation provisions issued by the legislator and the provisions of the local energy supplier must be observed.
- The leakage current of the Stratos MAXO is $I_{\text{leff}} \leq 3.5$ mA
- The electrical connection must be made via a fixed connecting cable equipped with a connector device or an all-pole switch with a contact opening width of at least 3 mm (VDE 0700/Part 1).

5.2.2 Motor protection

The standard integrated motor protection device reliably protects the pump, in all settings, against excess temperature, excess current and blocking. This has the following advantage:

→ No external motor protection switch is required.

The connection instructions of the local energy supply companies must be observed.

If, in the case of replacement, there is a motor protection switch in the electrical installation that cannot be bridged, then it is to be set to the maximum current specified on the rating plate.

5.2.3 Connection of accessories to AI1 and AI2 analogue inputs

The following signals can be connected to the analogue inputs:

→ PT 1000

→ 0 – 10 V

→ 2 – 10 V

→ 0 – 20 mA

→ 4 – 20 mA

They must be configured to the corresponding signal on commissioning of the pump.

The analogue input has a terminal to supply active sensors with 24 V DC.

→ Maximum current load: 50 mA

→ Electric strength 30 V DC / 24 V AC

→ Analogue input load at (0) 4 – 20 mA: $\leq 300 \Omega$

→ Load resistance at 0 – 10 V: $\geq 10 \text{ k}\Omega$

Connection of external temperature sensors

A 2-wire PT 1000 temperature sensor is connected to one of the two analogue inputs, AI 1 or AI 2. The input to be used can be freely selected. When adjusting the pump during commissioning, the selected analogue input is configured for its use as a PT 1000 actual value sensor and its position in the pipe network (e.g. feed sensor or return sensor) via the display. If two PT 1000 temperature sensors are connected, both analogue inputs are configured.

If the temperature sensors are at a large distance from the pumps, the fact that the line resistance will distort the measured values must be taken into account. As a result, the longer the supply line is to the sensor, the higher the measured temperatures become. In this case, it is recommended to use an active temperature sensor with 0 – 10 V output.

Connection 0 – 10 V/2 – 10 V – contact

A 2-wire cable for an external 0 – 10 V / 2 – 10 V signal from e.g. a heat generator or an active sensor is connected to one of the two analogue inputs, AI 1 or AI 2. The input to be used can be freely selected. When adjusting the pump during commissioning, the selected analogue input is configured for its use as a 0 – 10 V/2 – 10 V – setpoint sensor via the display.

For the 2 – 10 V signal type, a value under 2 V is detected as a cable break. The pump then runs with a defined emergency speed and reports a fault.

Connection 4 – 20 mA – contact

A 2-wire cable for an external 4 – 20 mA signal from e.g. a differential pressure sensor is connected to one of the two analogue inputs, AI1 or AI2. The input to be used can be freely selected. When adjusting the pump during commissioning, the selected analogue input is configured for its use as a 4 – 20 mA setpoint sensor via the display.

5.2.4 Connection of digital input DI1 and DI2

The pump can be controlled with the following functions via external potential-free contacts at the DI1 or DI2 digital inputs:

→ External OFF

→ External MAX

→ External MIN

→ External MANUAL

→ External key lock

In systems with a high switching frequency (> 100 on/off operations per day), on/off switching takes place via Ext. Off. External OFF is recommended as the pump kick remains functional.

5.2.5 Connection of potential-free contact for SSM and SBM

If the pump transmits a collective fault signal (SSM) and a collective run signal (SBM) to the building management system, a 3-wire cable connects the potential-free contact to the SSM and SBM inputs. When adjusting the pump during commissioning, the outputs' behaviour is configured via the display:

→ SSM as a potential-free changeover contact (signal only when error has occurred or when warning is given) or

→ SBM as a potential-free normally open (NO) contact (signal for power supply, ready for operation or in operation, or motor running.)

Contact load:

Permitted minimum: SELV 12 V AC/DC, 10 mA

Permitted maximum: 250 V AC, 1 A, AC 1 / 30 V DC, 1 A

5.2.6 Connection of Wilo Net BUS system

Wilo Net is a stand-alone BUS system which enables up to 11 Stratos MAXO pumps to communicate with one another. Wilo Net is used e.g. in the Multi-Flow Adaptation control mode, in which the feeder pump is informed of the respective volume flow demands of the connected pumps and thereby supplies the total required volume flow. The 3-wire 3 x 1.5 cable is connected to the Wilo Net connection with ferrules. Shielded cables must be used for cable lengths ≥ 2 m.

The following must be observed for the BUS topology:
The pumps communicating with one another are installed in series in a topology line. The BUS must be terminated at the first and last Stratos MAXO in the topology line. This is configured in the menu of both of these pumps. The termination must not be activated for all other pumps in the line.

All BUS participants must be assigned an individual BUS address that is set in the Stratos MAXO menu.

5.2.7 Installation and cabling of CIF module

The CIF module with the requisite BUS protocol to connect to the building automation is inserted into the designated position in the terminal room of the Stratos MAXO and wired-up accordingly.

wilo

WILO SE
Nortkirchenstraße 100
44263 Dortmund
Germany
T +49 231 4102-0
F +49 231 4102-7363
wilo@wilo.com
www.wilo.com

Pioneering for You