

Submittal Data Sheet

Wilo CO-Helix - NSF 61/372 Pressure Boosting System



CO-2 HELIX V50-08-1/7.5/VCE



| | |
|---------------|-------|
| Project: | |
| Engineer: | |
| Contractor: | |
| Submitted By: | Date: |
| Approved By: | Date: |

| Tag # | Model # | Flow | BOOST PSI | Min. Inlet PSI | HP/Pump | Phase | Voltage | RPM |
|-------|-----------------------------|------|-----------|----------------|---------|-------|---------|------|
| | CO-2 HELIX V50-08-1/7.5/VCE | | | | | | | 3600 |

CO-2 HELIX V50-08-1/7.5/VCE

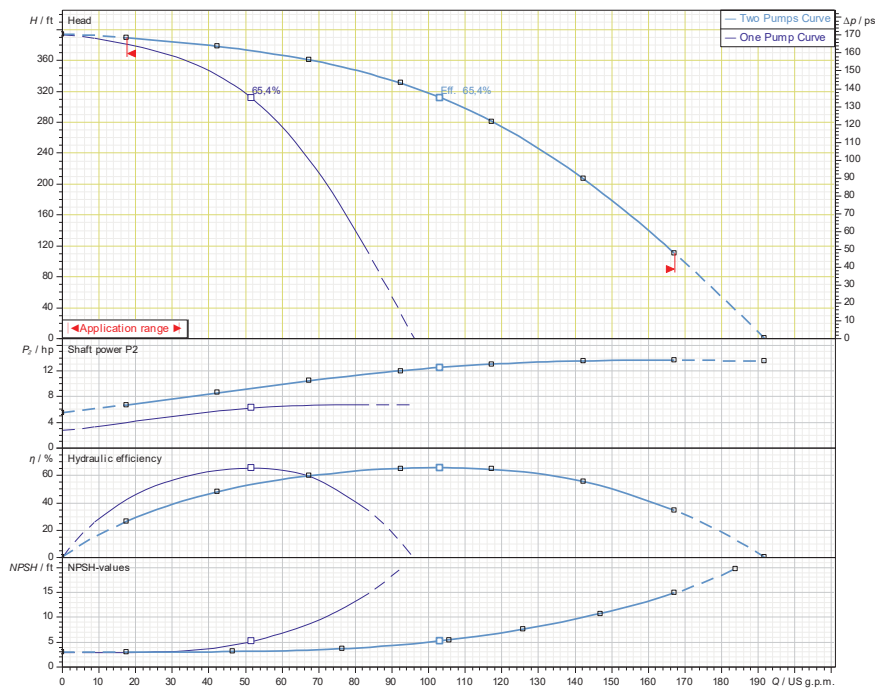

Applications

- Water Supply
- Agriculture
- Washing / Sprinkling Systems
- Pressure Boosting
- Cooling Circuits
- Condensate Return

Materials of Construction

| | |
|-----------------------------|---|
| Pump Volute | AISI304 stainless steel with ANSI flanges |
| Impeller | 3D Laser welded AISI 304 Stainless Steel |
| Shaft | AISI304, AISI318 LN, or AISI431 Stainless Steel |
| Elastomers | EPDM |
| Isolation Valves | 304 Stainless Steel Ball Valves |
| Suction/Discharge Manifolds | AISI304 Stainless Steel with Male Threaded System Connections |
| Check Valves | Wafer Style, 316 Stainless Steel internals, Non-slam, Plunger-type with EPDM seal/ Cast Iron Body |
| Mechanical Seal | Cartridge Seal: Sleeve AISI316L / Spring Clips AISI304 |
| Pressure Transducers | 316 Stainless Steel |
| Pressure Guages | 304 Stainless Steel Housing with 316 Stainless Steel wetted parts |
| System base | Steel (S235JR) |
| Vibration Isolators | Neoprene, Height Adjustable |

Technical Data - Operational Ranges

| | |
|---------------------|--|
| Liquid Temp Range | -4°F to +248°F (Min. 32 °F for Domestic Water) |
| Ambient Temp Range | +32°F to +104 °F |
| Max Inlet Pressure | 145 PSI |
| Max System Pressure | 232 PSI |

Technical Data - Panel

| | |
|---------------------------|--|
| Power Supply | 208-230/460-3 or 575-3 |
| Enclosure | NEMA 12 (3R Available Upon Request) |
| Standard | Meets UL 508A |
| Variable Frequency Drives | Danfoss FC-51 (1-10 HP for 208-23/460v~3) Danfoss FC-101 (1-10 HP for 575v~3) |

Technical Data - PLC

| | |
|---------------------------|--|
| User Interface | 7" Diagonal Color LCD Touchscreen |
| Display Resolution | 800 x 480 Pixels |
| Supply Voltage | 24VDC |
| Max. Current Consumption | 320mA@24V |
| Number of Analog Inputs | 9 |
| Number of Analog Outputs | 2 |
| Number of Digital Inputs | 18 |
| Number of Digital Outputs | 17 |
| Onboard Communications | Modbus Protocol (Optional Gateways for BacNET, LonWorks, and CANbus) |
| Ethernet Port | RJ45 port capable of transmitting data 10/100Mbps |
| Additional Ports | 2.0 USB Port; Micro-SD Port |

Motor Data

| | |
|------------------------|---|
| Power Supply | 208-230-3 or 460-3 or 575-3 |
| Motor Enclosure | Totally Enclosed Fan Cooled (TEFC) |
| Motor Efficiency | Nema Premium Efficiency (IE3) - Meets NEMA 12-12 Rule |
| Enclosure Construction | Rolled Steel / Cast Iron |
| Motor Protection Index | IP54 |
| Insulation Class | F |

Approval Stamp

Submittal Data Sheet

Wilo CO-Helix - NSF 61/372 Pressure Boosting System



CO-2 HELIX V50-08-1/7.5/VCE

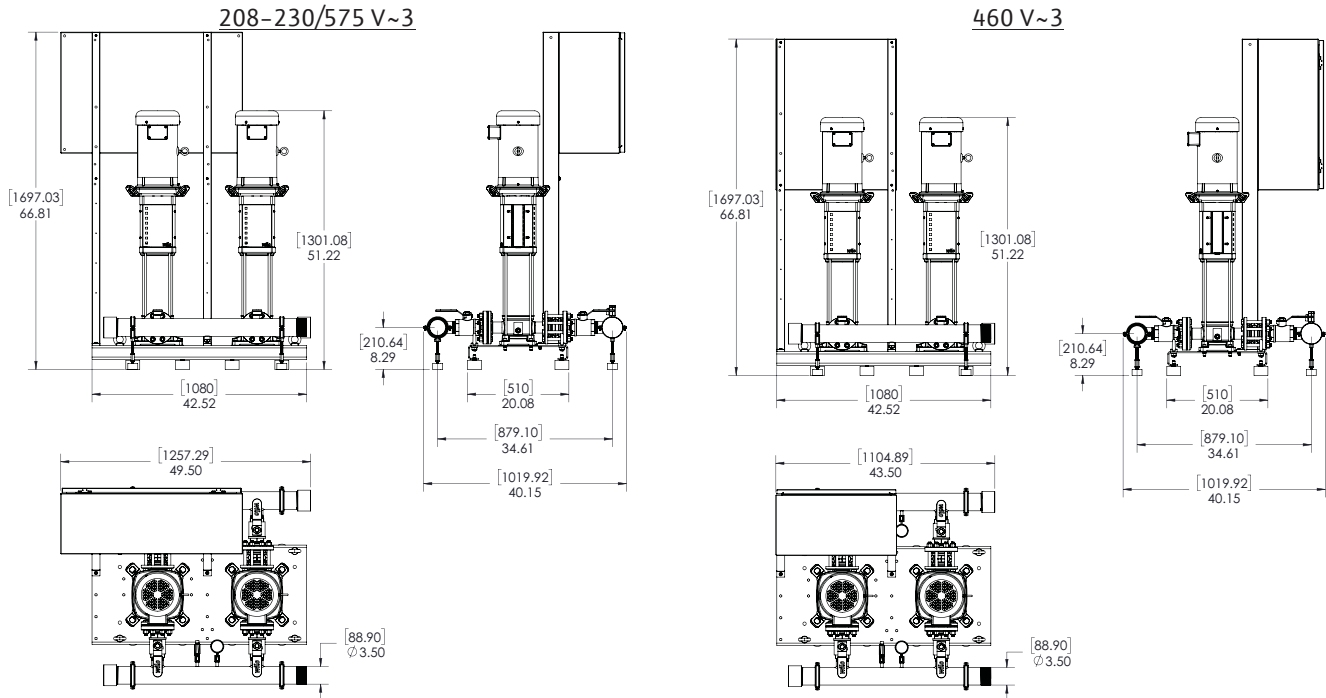

Special Note: All weights and dimensions are approximate and should not be used as exact rough-in dimensions

Dimensions and Weights

| Model | Voltage (V) | Dimensions-inches | | | | | | | | Individual Pump Weight | Package Weight |
|-----------------------------|---------------|-------------------|--------|--------|--------------------|--|----------------|---------------------|---|------------------------|----------------------|
| | | H (in) | W (in) | L (in) | System Header Size | Suction / Discharge Pump Size (300 Class ANSI) | Gauge Tap Size | Transducer Tap Size | Hydronumatic Tank Valve on Manifold (Plugged) | Pump Weight (lbs) | Package Weight (lbs) |
| CO-2 HELIX V50-08-1/7.5/VCE | 208-230/575 V | 66-7/8 | 49-1/2 | 40-1/8 | 3" MNPT | 2" | 1/4" FNPT | 1/4" FNPT | 3/4" MNPT x 3/4" FNPT | 223 | 772 |
| | 460 V | 66-7/8 | 43-1/2 | 40-1/8 | | | | | | | |

TEFC Motor Data

| Model | P2 (HP) | Phase (-) | Voltage (V) | FLA (per pump) (A) | Pmax (PSI) |
|-----------------------------|---------|-----------|-----------------|--------------------|------------|
| CO-2 HELIX V50-08-1/7.5/VCE | 7.5 | 3 | 208-230/460/575 | 17.2-16.2/8.1/6.8 | 232 |