

Pioneering for You

Pumps and pump systems for water supply, sewage disposal and sewage treatment.

Submersible Pumps and Mixers

FA, RZP, Miniprop, Uniprop, Megaprop/Maxiprop



Same Products
New **Color**

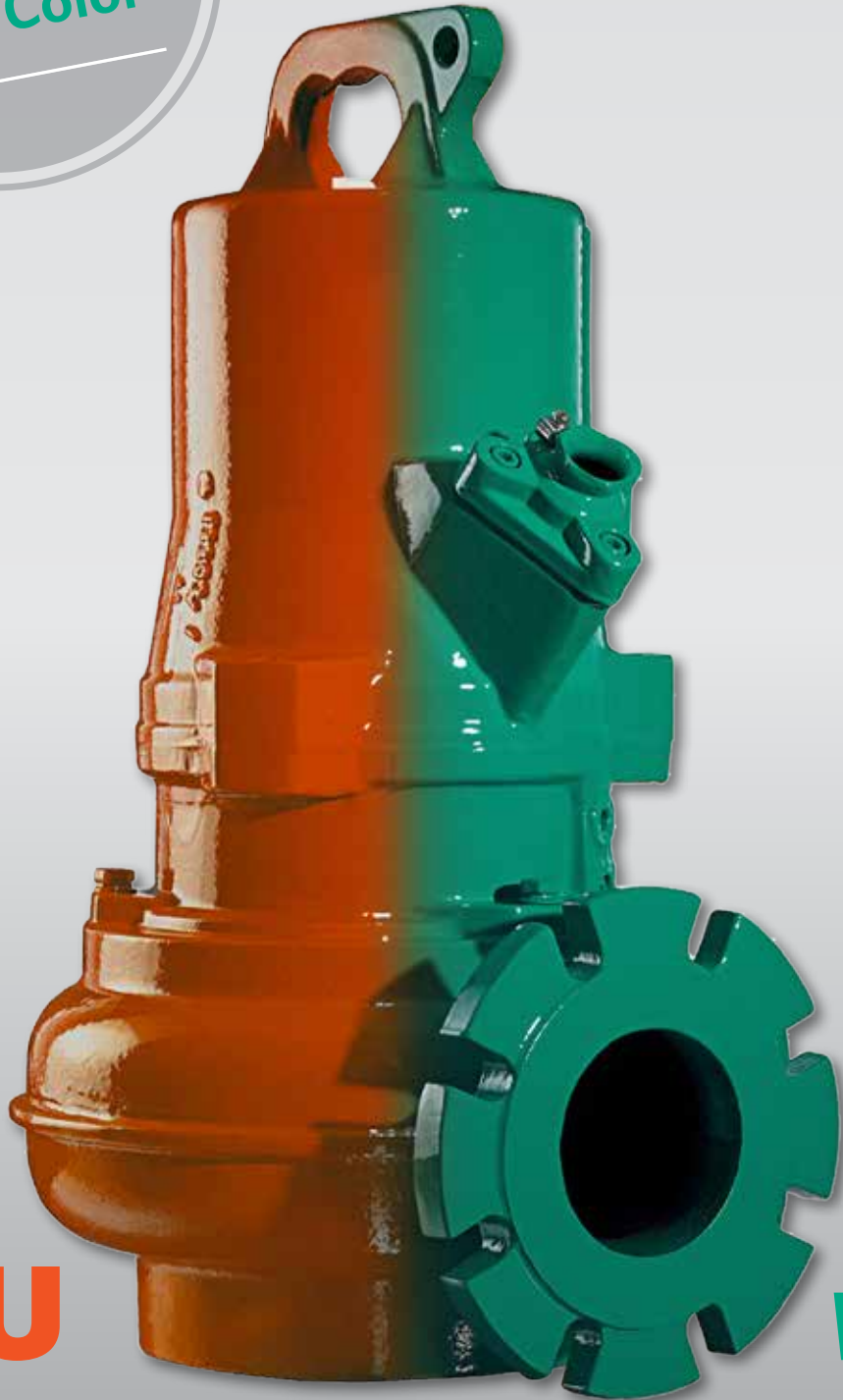

EMU

wilo

Wilo

Pioneering for You.



We are there for you worldwide.

1872 – Today. Louis Opländer founded Wilo AG as a copper and brass factory, later introducing the world to the first circulating pump. Wilo quickly grew and expanded internationally. Today Wilo SE, headquartered in Germany, is one of the world's leading manufacturers of pumps and pump systems for heating, air-conditioning and cooling, water supply and sewage disposal. With over 7,000 employees and 70 subsidiaries worldwide, we personally see to it that our customers' wants and needs are optimally met every day – with pioneering developments, high-efficiency products, and tailored solutions.

We are there for you locally.

1971. The first EMU submersible sewage pumps arrived in America. At first, little notice was paid to these bright orange pumping machines, but as time passed and experience grew, the popularity of EMU submersible pumps grew into a following, and from there into an industry legend.

1985. EMU mixers were introduced in America. They drew attention quickly and were installed in several plant sites throughout the country.

2003. Wilo North America was founded in Calgary, Canada.

2003. WILO AG purchased EMU GmbH in Germany through a mutual agreement.

2005. Wilo-EMU became a subsidiary of Wilo North America, with headquarters in Thomasville, Georgia. Later in 2007, the manufacturing facility was built in Thomasville.

2005. Wilo North America opened offices in Illinois and brought the high efficiency Stratos circulator, along with additional building services products to American market.

2010. Wilo-EMU in Georgia and Wilo in Illinois merged, forming one company, Wilo USA. Offices in Calgary, Canada remain, and operate under the name Wilo Canada.

Today. Wilo USA continues to offer highly reliable and extremely durable submersible pumps & mixers, as well as a full line of high efficiency pumps, commercial pumps, and well pumps. With the headquarters in Rosemont, IL and manufacturing in Thomasville, GA, Wilo USA continues to provide new technology and innovative pumps & mixer solutions to the country.

That's what we call Pioneering for You.

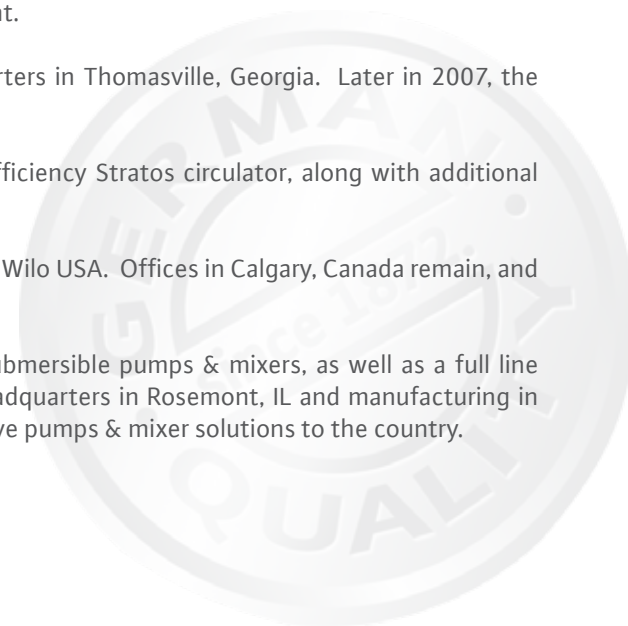

Wilo FA

Submersible Sewage Pump

Applications:

- Sewage Collection
- Storm Water
- Raw Water
- Sewage Treatment
- Dewatering
- Industry



Features & Benefits

- Rugged design for portable, wet pit, and dry well installation
- Shaft - Short overhang / large diameter
- L3/D4 Shaft Bending Ratio lowest in industry
- Continuous operation possible in Q vs H curve extremes
- Internally closed loop cooled motors available

Technical Data

- S1 Operating Mode (continuous duty)
- Protection class: IP 68
- Max Temp: 104°F (40°C)
(higher temperatures on request)
- Silicon carbide mechanical seals
- Max flows: 23,000 USGPM
- Max Head: 420 feet

Materials of Construction

- Cast Iron Volute (standard)
- Stainless Steel Standard Shaft
- Optional Materials of Construction and Coatings Available

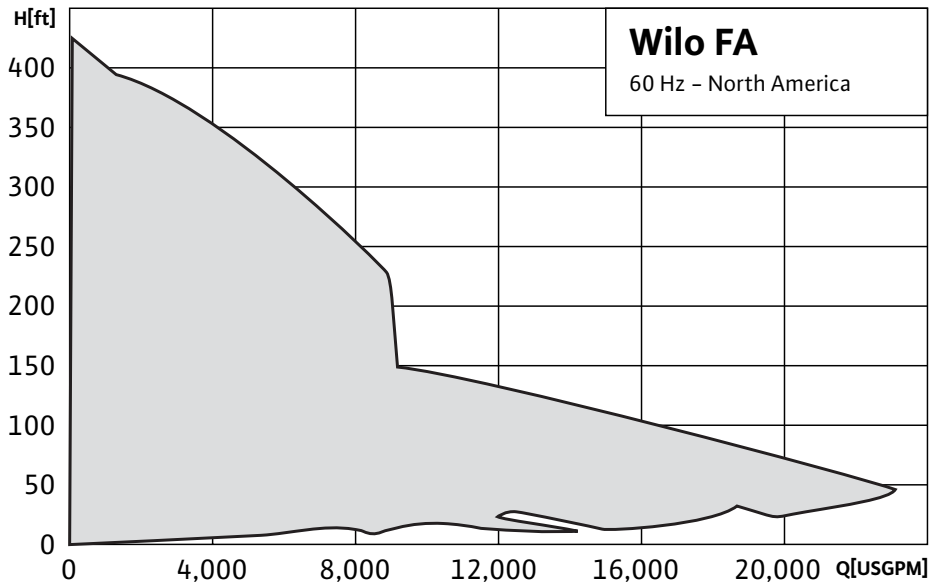

Wilo Solid Impeller

The Solid Choice

Applications:

- High solids content (rags and fibrous)
- Untreated sewage
- Local drainage



Features & Benefits

- **Handles flushable wipes, fibrous solids and rags!**
- Solids passage of a vortex impeller with the efficiency of an enclosed non clog impeller.
- Smooth operation
- Operation in wet and dry well installation
- Simple installation via suspension unit or pump base
- Special materials (Abrasil) and Ceram coatings against abrasion and corrosion
- Impeller trimmed to specific duty point
- Free passage: 3x4 - 7x7 in (78x105 - 170x170 mm).

Motor Data

- Longitudinally watertight cable inlet
- Power connections: 3~230 V, 3~460 V
Optionally 200 V, 203 V, and 575 V
- Submerged operating mode: S1
- Partially submerged operating mode with self-cooling motor: S1
- Dry-pit operating mode with dry motor: S2-15 (depending on type)
- Protection class: IP 68
- Max. fluid temperature: 37 - 104 °F (3 - 40 °C)
(higher temperatures on request)
- All seal faces are silicon carbide
- Permanently lubricated roller bearings
- Max. immersion depth: 65 ft (20 m)

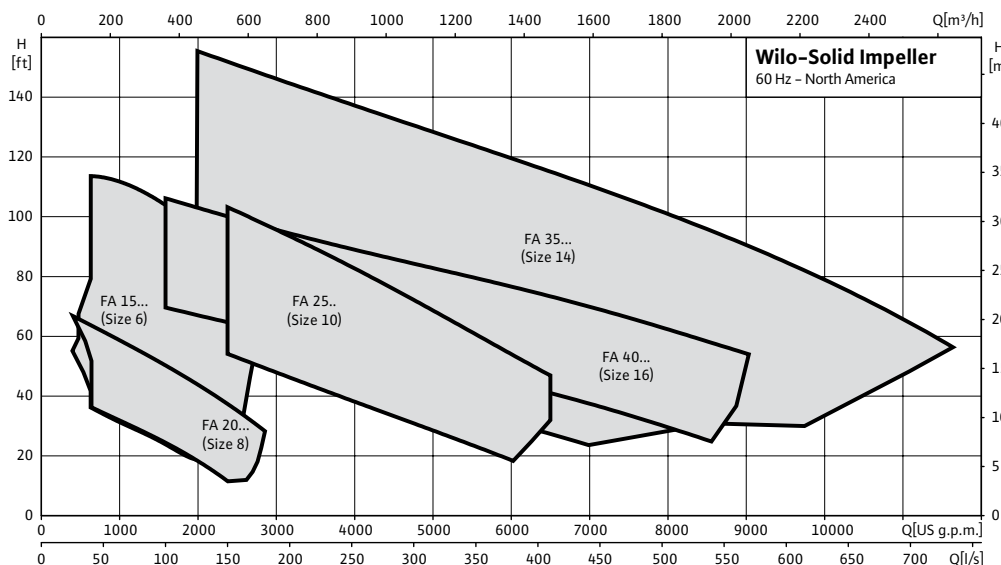

Wilo FA Impellers

Modular system impellers

Solid Impeller



- Handles flushable wipes, fibrous solids, and rags!
- Solids passage of a vortex impeller with the efficiency of an enclosed non clog impeller.

Modular System

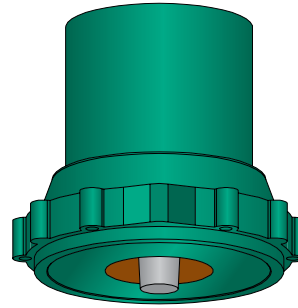

- Multiple combinations of pump ends and motors to fulfill the requirements of each project.

Single-Channel Impeller

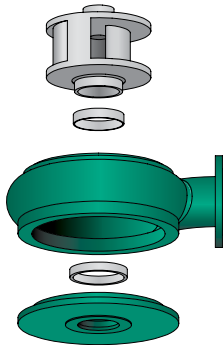

- Low to medium capacity at medium to high heads
- Raw unscreened sewage and dewatering applications
- Return and Waste Activated Sludges and recycled sludge

Multi-Channel Impeller

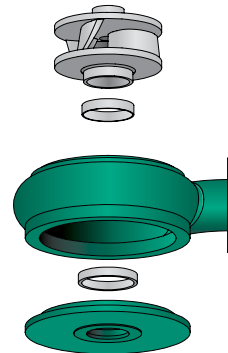

- Raw unscreened sewage of Screened wastewater and sludges, storm water and drainage applications.

Vortex-Type System

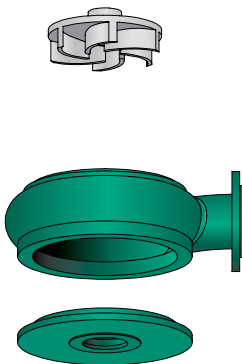

- Raw unscreened sewage and dewatering applications
- Raw and digested sludges with up to 8% solids
- Best in solids passage and abrasive duty
- Mixer head available for grit entrainment

Propeller-Type System

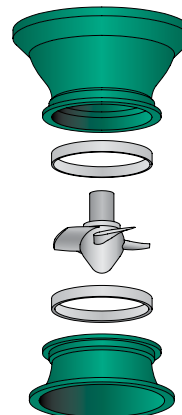

- High capacity at low heads
- Storm water, irrigation and well screened wastewater
- Return sludge and recycle of activated sludge in wastewater treatment plants

Wilo FA Motors

FK, HC, FKT, & T Motors

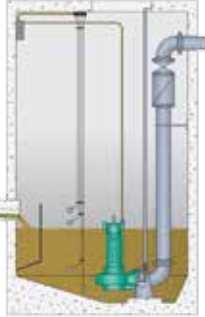

Wet Sump Installation

- Low costs for lift station and assembly
- Low space requirement for the pumps
- Service-friendly installation and removal
- Motor is cooled by the pumped media

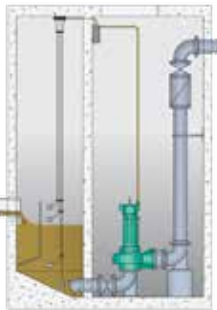

Dry Sump Installation

- Accessible pump chamber
- Pump can be monitored during operation
- Quick repairs under hygienic conditions
- Pump remains in operation in case of flooding
- Internal cooling system, external cooling not required

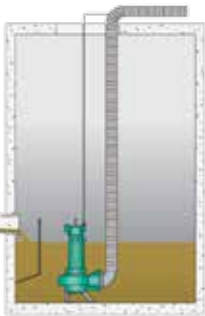

Transportable Installation

- Deep, narrow shafts
- Shallow basins
- Dewatering on construction sites
- Industrial and municipal sewage disposal
- Sewer renewal

FK Motors



FK motors feature an oil-filled motor chamber. By means of an internal oil circulation cooling system, the heat produced by the motor is dissipated to the pumped media via a heat exchanger. The type FK 17.1 of this series is available in explosion-proof design.

HC Motors

HC motors are air filled with a closed loop water/glycol cooling system. The heat of the motor is dissipated to the pumped liquid by the cooling liquid – driven by a magnetic coupling – by means of a highly efficient heat exchanger. This series is available in explosion-proof design.



FKT Motors



FKT motors are air filled with a closed loop water/glycol or oil cooling system. The motor heat is dissipated to the pumped media via a heat exchanger. This series is available in explosion-proof design.

T Motors

Air filled T motors are cooled when submerged in the surrounding pumped media. Here, the motor waste heat is dissipated directly via the casing, to the pumped medium. The types of this series are available in explosion-proof design.



Wilo FA Accessories

Block seal, materials, designs



Enclosed Block Seal

Mechanical shaft seals of high wear-resistant silicon-carbide at the motor and pump-side integrated in a stainless steel cartridge

- Short height compact design (short shaft overhang)
- High operation safety
- Durable and long life
- Operation independent of the direction of rotation



Special Materials

- Wear-resistant materials and coatings
- Corrosion-resistant materials and coatings
- Ceram coatings



Special Designs

- Mechanical mixing head
- Grinder pumps
- Cast stainless steel
- High chrome cast iron



Wilo Miniprop & Uniprop

Submersible Mixers



Wilo Miniprop TR 21

- Submersible mixer with optimized blade profile
- Propeller made of made wear resistant PUR



Wilo Uniprop TR 365

- Heavy duty propeller for heavy sludge and storm water applications



Wilo Uniprop TR 75-2

- Standard version with flow optimized PUR propeller for a wide range of applications

Wilo Miniprop

These submersible mixers are particularly suited to applications in small pumping stations. They are used for maintaining solids in suspension, so they can be pumped on for further treatment, and also for dispersing grease and light solids, that tend to form a floating solids layer in these stations.

Wilo Direct Drive Uniprop

Wilo's smaller direct drive Uniprop mixers are ideal for continuous duty applications in wastewater treatment plants. Whether you have a small BNR or sludge holding basin, Wilo has a mixer that is ideal for your application. These heavy-duty units can be used for blending influent streams, or for keeping solids in suspension.

Wilo Gear Driven Uniprop

Wilo's gear driven mixers are designed for efficiency and durability, and suitable for a wide range of wastewater treatment applications. Our molded polyurethane propellers are designed to provide maximum thrust and flow generation, and to minimize the radial losses that require the use of jet rings. The compact in-line planetary gear sets provide stability and efficient speed reduction. Two sets of bearings between the gear set and propeller provide additional mechanical stability. The combination of using large diameter efficient propellers operating at low speeds gives Wilo the opportunity to choose mixers that provide superior mixing performance with minimal power use, often saving thousands of dollars a year in power costs when compared to direct drive options. The slower turning propeller reduces wear on the mixer's bearings and seals, which means longer life, greater reliability, and lower maintenance costs.

The PUR hydrofoil blade design provides two zones of lift similar to an airfoil. Two zones of lift essentially double the efficiency of the blade compared to an equivalent SS blade. Also, the flow is laminar across the hydrofoil profile, eliminating the need for an anti-vortex shroud. A Ceram C0 ceramic coating is provided as a standard on Wilo Uniprop mixers for protection against abrasives and corrosives.

Wilo offers a 4 year 100% warranty on planetary mixers.



Wilo TR50 Gear-Driven Mixer

Wilo Megaprop & Maxiprop

Submersible Mixers

Wilo low-speed mixers are available in two or three-blade configurations. For equal thrusts, the loading is distributed on two blades with the Maxiprop and on three blades with a Megaprop.

A three-blade design ensures smooth operation even in unfavorable flow conditions. Extremely durable one-piece laminated GRP blades ensure maximum periods of use and minimum maintenance costs, and can also be replaced individually. "Slow runners" are ideal for creating a directed flow in water treatment systems and for suspending solids. In activated sludge tanks, biological phosphorus removal tanks and denitrification tanks, they prevent activated sludge from settling. This makes Wilo's low speed mixers suitable for a wide range of applications in water treatment technology, industry, agriculture and water supply.

Equipment.

Wilo Maxiprop and Megaprop submersible mixers are available with propeller diameters from 1,600 mm (5.25') to 2,600 mm (8.5'). Depending on the submersible motor (4, 6 and 8-pole motors are available) and the transmission of the planetary gear, propeller speeds between 17 and 77 rpm are possible. The resulting mixing forces are absorbed by the oversized gear mounting, and are not passed to the motor bearings. A thermal sensor and a three-chamber system are part of standard construction. The gear shaft is made of saltwater-resistant AISI 329 duplex stainless steel (1.4462). The standard protective sleeve, the hub closing ring and the well-designed propeller geometry reliably prevent any entangling. The counter ring of the mechanical seal is pressed into a stainless steel bushing to prevent any corrosion. The submersible mixer is optionally available with an explosion proof rating according to the FM or CSA standard. The submersible mixers are equipped with an external sealing chamber control as an option. We recommend our Ceram C0 coating for applications in abrasive and/or corrosive fluids.



Modular Design.

With all Wilo submersible mixers, the submersible motor, the gear and the propeller form a compact unit of individual components that enable the precise adjustment of the mixers to the required performance data. With all of our units, ideal mixing results are based on modularly applicable propeller diameters and speeds. With the use of 4, 6 or 8-pole submersible motors and various gear transmission ratios, the propeller speed may vary as required to provide the optimal mixing energy. Due to the modular system used by Wilo, the motor, the gear and the propeller can be combined in many ways so that a large range of submersible mixers and pump curves are available.

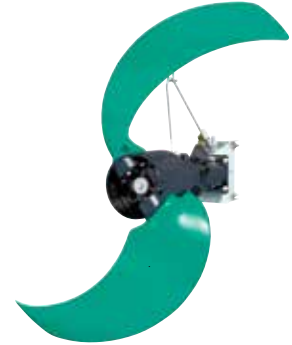

Wilo Maxiprop TR 221 (2-blade)

- Low speed submersible mixer
- One-piece GRP laminated blades for maximum periods of use



Wilo Megaprop TR 326 (3-blade)

- Innovative blade shape for very smooth operation
- Self-cleaning effect due to backward bent blades
- Up to **10% energy cost savings** compared to similar low-speed mixers

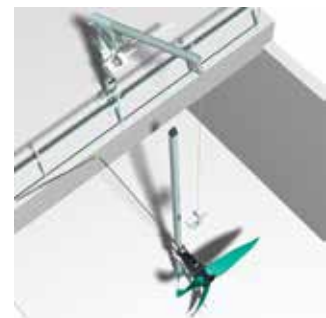

Accessories

- Wilo provides all accessories – from guide pipes, frames and sliding carriages to rubber buffers
- Wilo mixers can be retrofitted onto any competitor's mixer guide / suspension system.

Wilo RZP

Recirculation Pumps

Applications:

- Low head water / sewage delivery at high flow rates
- Process, raw, pure and cooling water
- Generation of fluid current in water channels

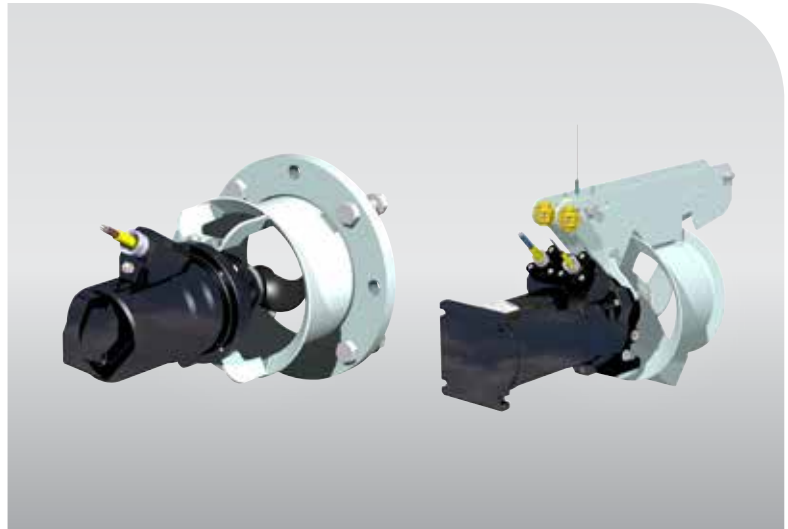

Features & Benefits

- Submersible, compact installation unit
- Vertical or in-line design
- Energy efficient, flow-optimized, self-cleaning propellers, partially with helix hub
- Low cost in-basin piping
- FM – Ex Rated
- Pump station wet wells are no longer necessary
- Easy installation and removal
- The special blade design provides gentle pumping of water, sewage and activated sludge

Technical Data

- Submerged operating mode: S1 (continuous duty)
- Max Temp: 104°F (40°C)
- Protection class: IP 68
- Units are planetary or direct gear driven
- Max flows: 30,000 USGPM
- Max Head: 17 feet

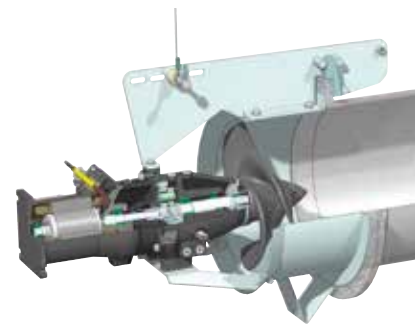
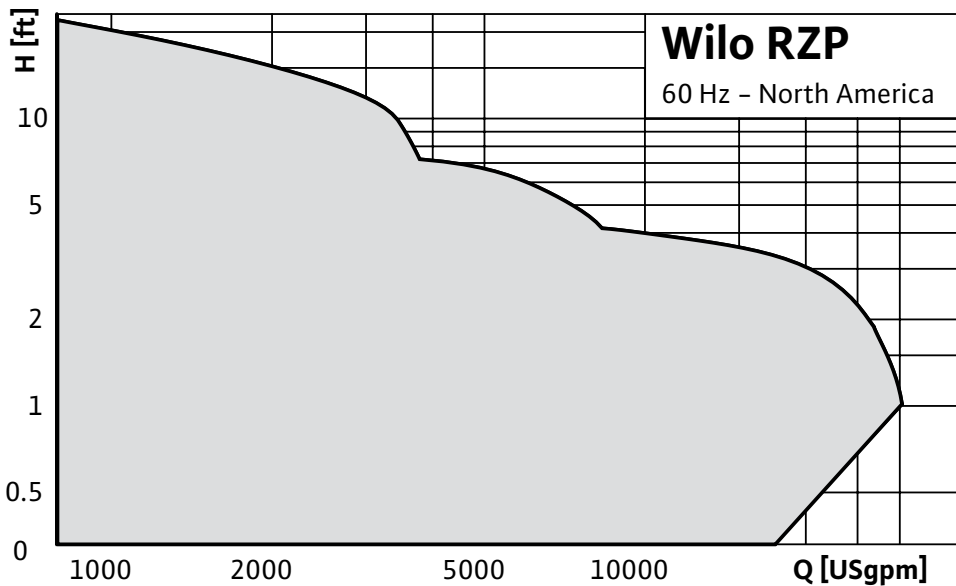

Wilo RZP

Installation

Installation

One of the most important design criteria for Wilo submersible product is the ease of installation and maintenance of the equipment – The Wilo RZP recirculation pump is no exception.

Standard Installation

Wilo recirculation pumps are coupled into place without any permanent fixation to the discharge piping and are guided back into position through the use of a specially designed guide rail system. This allows the operator to provide maintenance and service without entering or dewatering the basin. Wilo provides auxiliary hoisting equipment specifically designed for each application.

Inline and Vertical Installation

In addition to our traditional mounting systems, Wilo recirculation pumps can be mounted in both vertical and inline positions.

After-sales service: fast, reliable, all across North America

The installation and start-up of Wilo recirculation pumps is done by our after-sales service – qualified technicians with many years of experience. Our support service is also ready to assist you for any repair or maintenance work required.

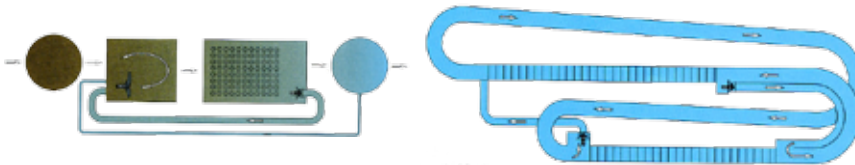

Sewage treatment plants

Modern biological nutrient removal (BNR) wastewater treatment plants are designed to remove total nitrogen and total phosphorus. Total nitrogen removal involves both aerated (nitrification) and anoxic (denitrification) processes. In this process, a high recycle volume of the treated wastewater is returned to an anoxic zone at the head of the plant so that the BOD of the raw sewage can provide a food source for the denitrifying micro-organisms. This recycle is at very high flows (up to 6 times the rated flow of the treatment plant) and very low heads. Higher recycle rates mean greater removal of nitrogen. Mixer wall pumps are usually most cost effective and efficient method to provide this recycle flow.

Amusement parks

One of the most popular attractions in any amusement or adventure park is the flume rides with their slow rise and rapid descent.

In a flume ride, the car is drawn mechanically up the flume then descends under its own weight. Large quantities of moving water are required for these rides – water which is cycled from the top to the bottom and back to the top.

This continuous water cycle is created by recirculation pumps. These pumps are specially designed for pumping big quantities of water at low head.



RZP 60-3 standard installation

→ Can be combined with a Wilo lowering device for installation in a full tank or basin.



RZP 50-3 vertical installation

→ The recirculation pump is permanently flange-mounted to the discharge pipe. For maintenance and repair the tank or basin must be emptied.

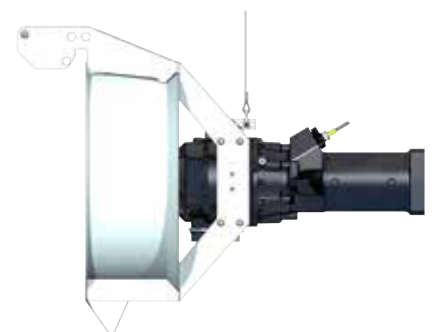

RZP 80-2 wall installation

→ Wedge and cantilever design keeps pump in proper operating position.

Wilco Energy Solutions

The Right Mix



→ **Energy Efficiency.**

→ **Advanced Technology.**

→ **Custom Solutions.**



Wilco's Right Mix is a premium service designed to showcase the superior quality and energy efficiency of our gear-driven mixers. Wilco's uniquely designed polyurethane propellers and gear-driven set up allow us to "dial in" the most efficient mixer selection for your application. Here's how it works!

- Fill out a Right Mix audit form, and include details on the existing mixer you'd like to replace. This will include make, model, and application. The more detail the better!
- Wilco will select an appropriate replacement mixer, and work with you to set an installation date. At this time, Wilco will also perform a "desktop" energy analysis showing you how much money your new mixer might save.
- During installation, an energy study will be performed on your old mixer as compared to the new Wilco mixer. The results will be put into an energy savings report which will show Return on Investment and Life Cycle Cost analysis. Savings can be dramatic!
- If you are satisfied with the results, simply authorize payment within 90 days and enjoy the quality and savings afforded by your new Wilco mixer. It's that simple!

A recent example from a wastewater treatment facility in Stanford, CT:

Energy Savings Analysis

Competitor's Direct Drive Unit = \$6,191.12 mixer/year

Wilco TR 75-2.19-6/16 = \$1,807.92 mixer/year

Wilco Savings: \$4,383.20 mixer/year = 71%

*Energy costs = \$0.15 kWh

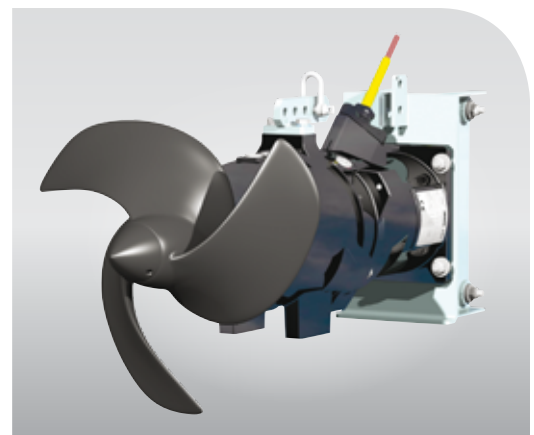



Wilo Test in Your Tank

No Obligation!

Here's how it works:

Simply request a Wilo mixer to "Test in your Tank", from your Wilo representative - No cost, no obligation. At the end of the trial period, if you don't think it's the absolute best mixer you've ever used, simply send it back, no strings attached! If you'd like to keep the mixer, simply authorize payment, and enjoy the benefits of Wilo mixer technology for years to come.

888-945-6872 | www.wilo-usa.com



Wilo TR326 MegaProp



Wilo TR90 UniProp



Wilo TR50 UniProp
(heavy duty)



Wilo TR21 MiniProp

Pioneering for You

wilo®



10-55-001-0914

WILO USA LLC

888-945-6872
www.wilo-usa.com
info@wilo-usa.com

WILO Canada Inc.

866-945-6236
www.wilo-canada.com
info@wilo-canada.com

WILO Mexico

+52 55 5586 3209
www.wilo-mx.com
info@wilo.com.mx