

# High pressure centrifugal pumps

## Wilo-Multivert MVI (North America)

### Series description

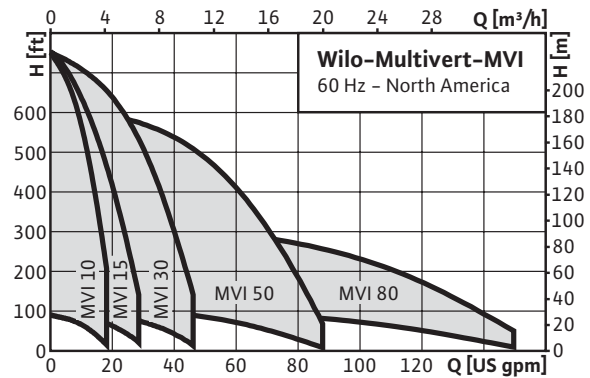

#### Pump series

Wilo-Multivert MVI 10.., 15.., 30.., 50.. and 80..

#### Construction

Non-self priming multistage pump

#### Applications

- Water supply and pressure boosting
- Fire extinguishing systems
- Boiler feed
- Industrial circulation systems
- Process engineering
- Cooling-water circuits
- Washing and sprinkling systems

#### Equipment and function

- 100% Stainless steel construction
- Same flange dimensions as offered by competitors
- Two flange types – dependent on model– 2-bolt oval flange with NTP threaded mating flange – ANSI 300 Lb 8-bolt round flange
- Standard Baldor Nema Frame Motor
- ODP or TEFC motor enclosures
- Built-in priming plug
- Built-in air venting plug
- Sleeve O-rings eliminate thermal stress leaks

#### Technical data

- Power supply 1 ~ 115 V / 60 Hz or 230 V / 60 Hz
- Power supply 3 ~ 208 V / 60 Hz, 230V / 60 Hz, 460 V / 60 Hz or 575 V, 60Hz
- Temperature range – 5 to 250 deg F with EPDM – 5 to 194 deg F with Viton
- Ambient temperature limits – Maximum 104 deg F – <90% humidity (motor-dependent)
- Maximum suction pressure 140 PSI

#### Materials

- Impellers and stage chambers  
Stainless steel AISI 304 (1.4301) optional AISI 316 (1.4404)  
(MVI 80.. only in AISI 306)
- Pump housing stainless steel AISI 304 (1.4301)  
optional AISI 316 (1.4404)
- Depending on type, the shaft is in stainless steel AISI 304 (1.4301)  
optional AISI 316 (1.4404)
- Seal EPDM (EP 851) / Viton
- Housing cover stainless steel AISI 304 (1.4301) optional AISI 316  
(1.4404)
- Housing bottom stainless steel AISI 304 (1.4301) optional AISI 316  
(1.4404)
- Mechanical seal B-carbon/tungsten carbide, SiC/carbon
- Pressure jacket stainless steel AISI 304 (1.4301) optional AISI 316  
(1.4404)
- Bearing tungsten carbide
- Pump foot cast iron EN-GJL-250

## High pressure centrifugal pumps

### Wilco-Multivert MVI

#### Hydraulic data

Inline stainless steel pump	•
Mechanical seal (seals in both directions of rotation)	•
Hydraulic in 1.4301	•
Hydraulic in 1.4301 Pump base in EN-GJL-250	–
2 Bolt oval type - companion flange threaded NPT	•
ANSI 300 Lb round flange for high pressure pumps	•

#### Motor

Three phase (208, 230, 460, 575 V)	•
Single phase (115, 230 V)	•
4-pole (n = 1750 rpm)	optional

#### Equipment/scope of delivery

Oval mating flange Rp 1 up to Rp 1½	•
Installation and operating instructions	•

#### Options

Hydraulic in 1.4404	•
Other mechanical seals	•
Other standard motors	•
Other seal materials	•

• = available, – = not available

## Variants overview Wilo-Multivert MVI

Wilo-Multivert MVI	
<b>Material</b>	
Parts in contact with the fluid medium in 1.4301 (AISI 304)	•
Parts in contact with the fluid medium in 1.4404 (AISI 316L)	optional
<b>Seals</b>	
EPDM	•
Viton	•
<b>Hydraulic connection</b>	
Oval flange	•
Round flange	•
<b>Motor versions</b>	
Individual motors	optional
1 ~ 115 V, 60 Hz	•
1 ~ 230 V, 60 Hz	•
3 ~ 208 V, 60 Hz	•
3 ~ 230 V, 60 Hz	•
3 ~ 460 V, 60 Hz	•
3 ~ 575 V, 60 Hz	•
Ex-protected motors	optional
Motors with resistors (PTC)	optional
Motors with UL certification	?
Motors with CSA certification	?
Motor enclosures	ODP or TEFC
Thermal motor protection	?
Speed controllable via remote frequency converter	•
Integrated frequency converter	–
<b>Paint finish</b>	
Individual paint finishes	optional
<b>Mechanical seals</b>	
Tungsten carbide/carbon	•
Tungsten carbide/Tungsten carbide	optional
SiC/SiC	optional

• = available, – = not available

## Variants overview Wilo-Multivert MVI

### Drinking water compatibility

KTW	•
WRAS	•

• = available, – = not available

# Pump curves Wilo-Multivert MVI

## Wilo-Multivert MVI 10...

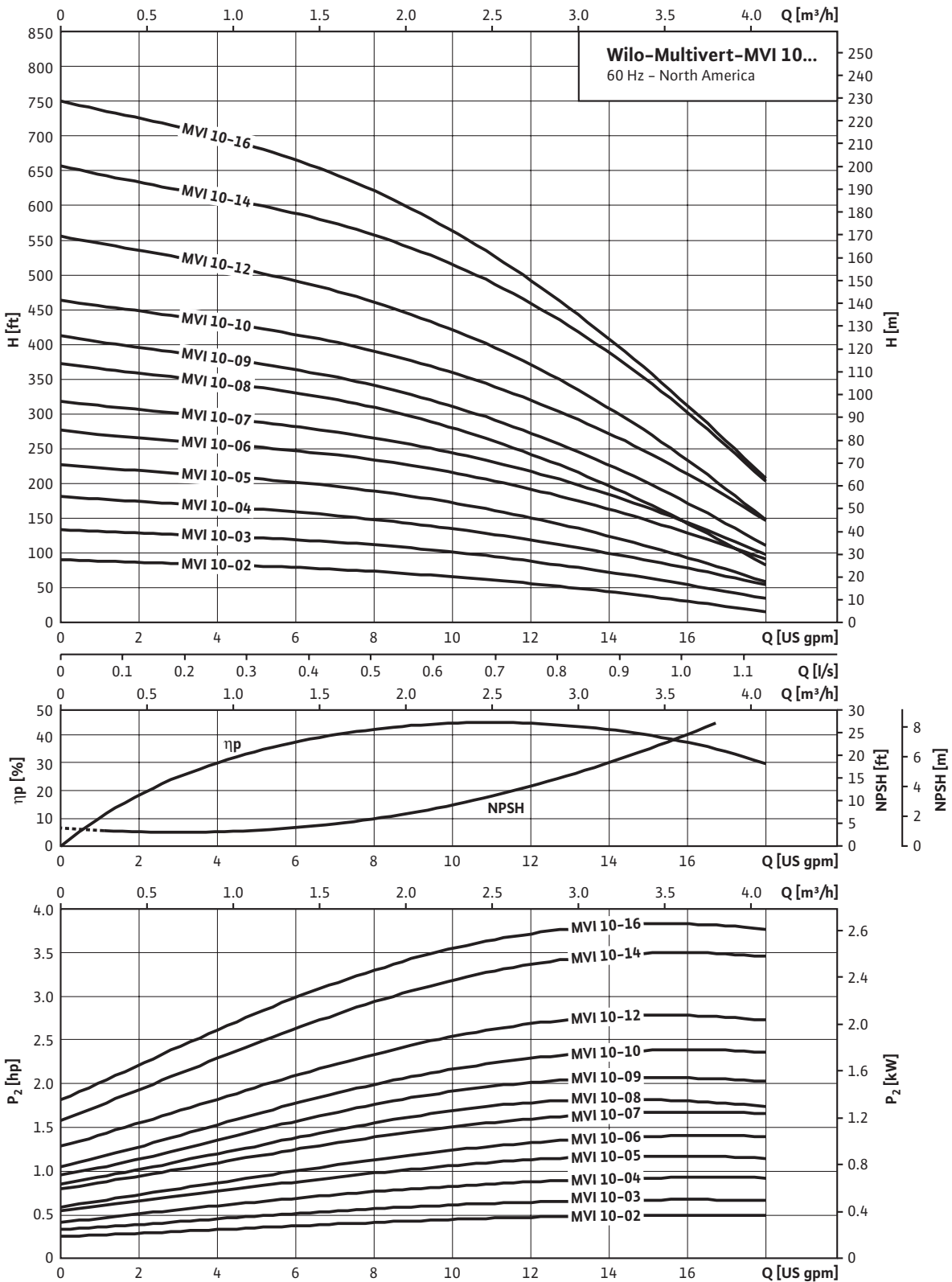

# Pump curves Wilo-Multivert MVI

## Wilo-Multivert MVI 15...

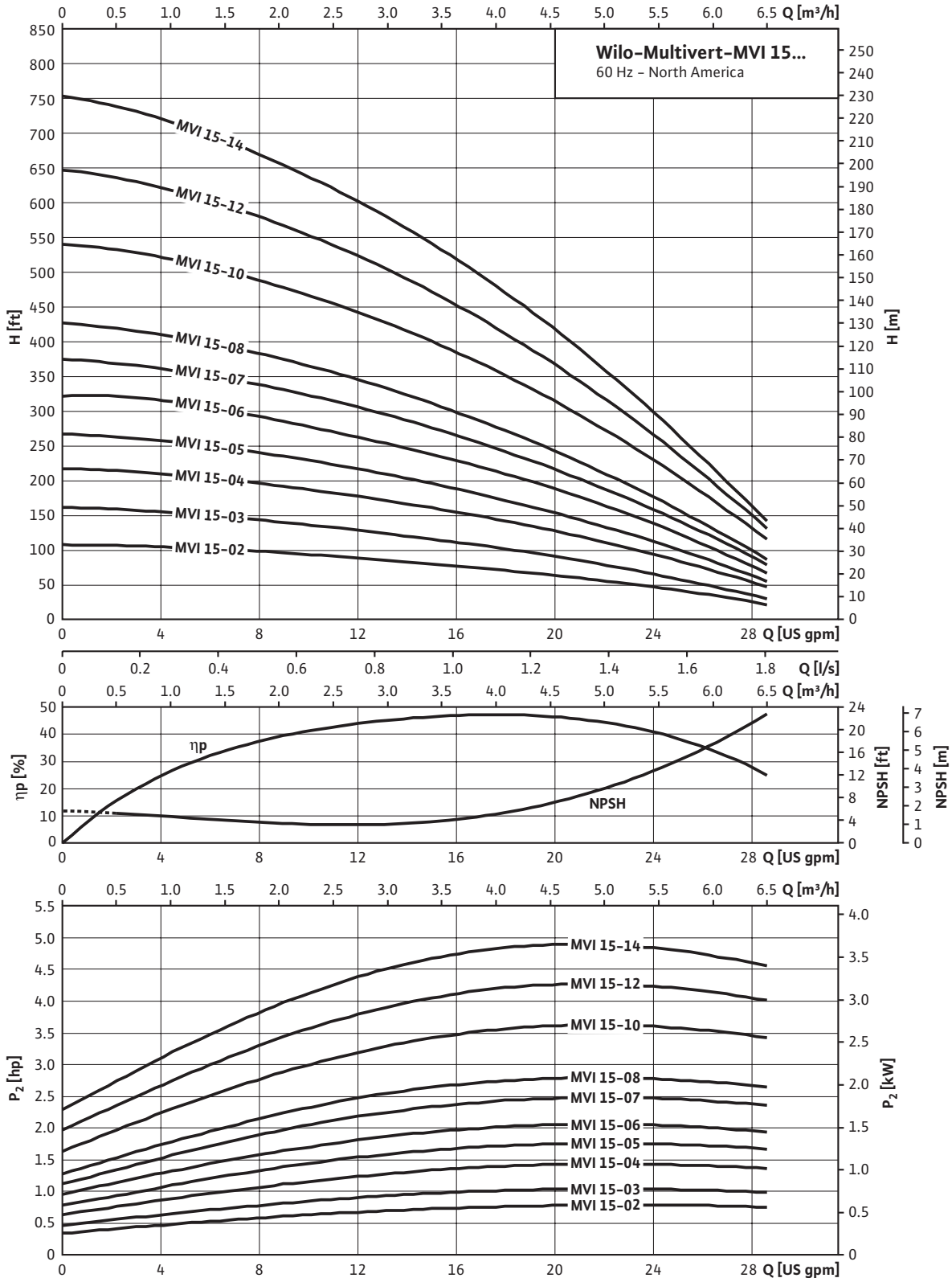

# Pump curves Wilo-Multivert MVI

## Wilo-Multivert MVI 30...

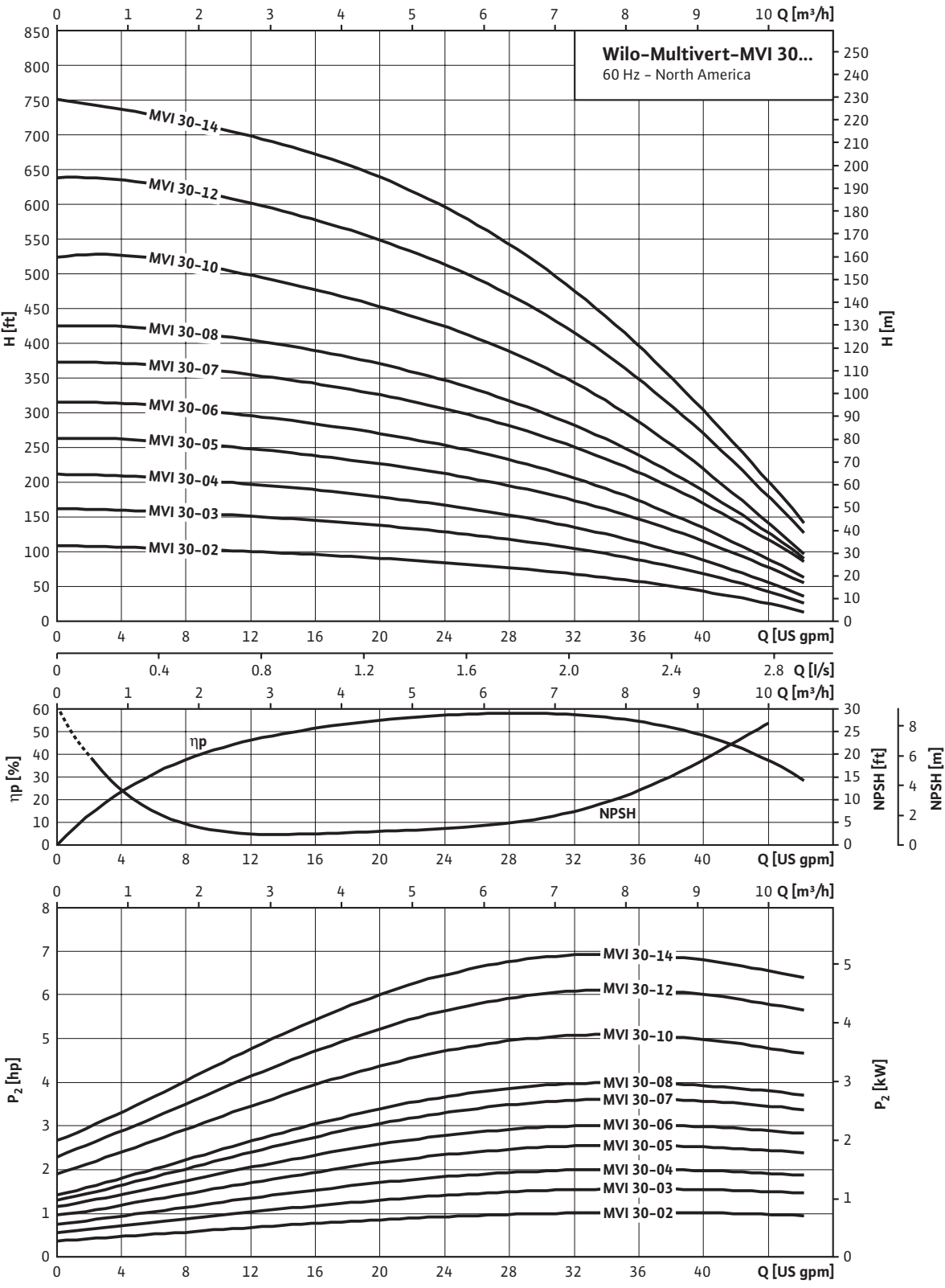

# Pump curves Wilo-Multivert MVI

## Wilo-Multivert MVI 50...

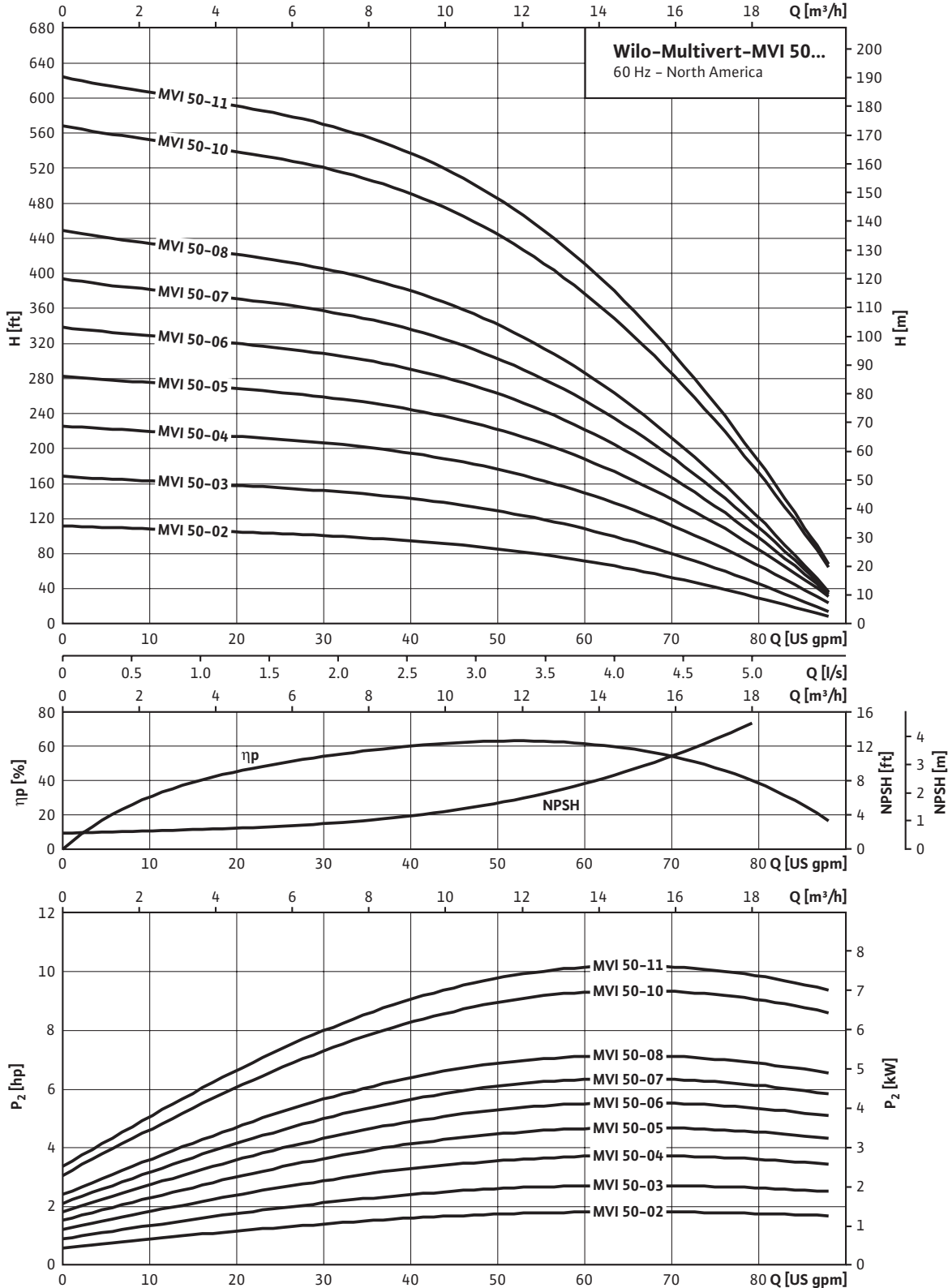



# Pump curves Wilo-Multivert MVI

## Wilo-Multivert MVI 80...

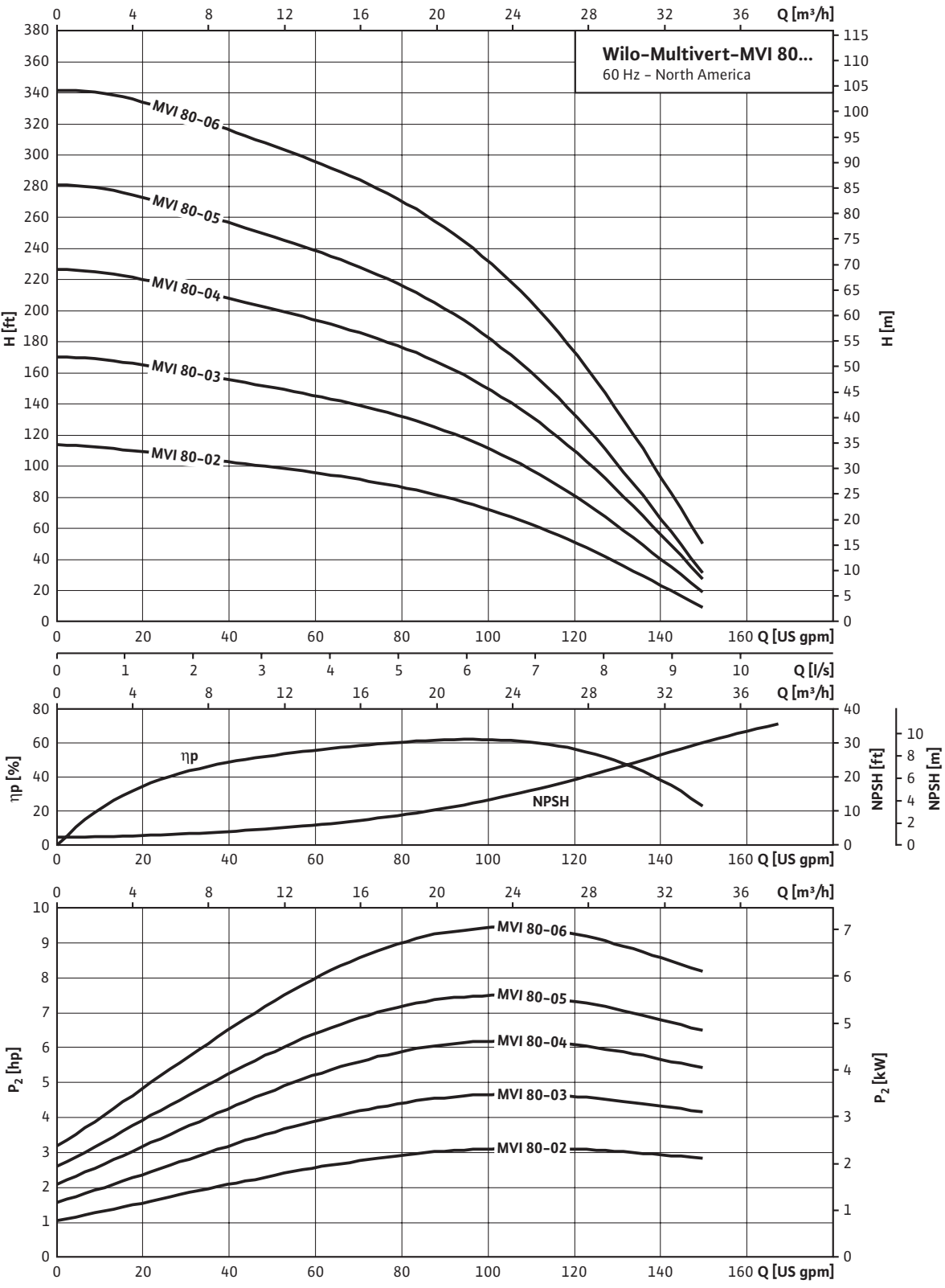

# High pressure centrifugal pumps

Wilo-Multivert MVI (North America)

## Motor Data Wilo-Multivert MVI

Motor Data							
Wilo-Multivert MVI ...	Rated power output		Full Load Current				
	P <sub>2</sub>		I (ODP motor enclosure)		I (TEFC motor enclosure)		
			3~208-230/460 60 Hz	1~115/230 60 Hz	3~208-230/460 60 Hz	1~115/230 60 Hz	3~575 60 Hz
	[hp]	[kW]	[A]	[A]	[A]	[A]	[A]
10-02	½	0.37	2.4-2.2/1.1	7.2/3.6	2.4-2.2/1.1	7.0/3.5	0.7
10-03	¾	0.55	3.2-3.0/1.5	9.6/4.8	3.2-3.0/1.5	9.4/4.7	1.0
10-04	1	0.75	4.1-3.6/1.8	15.0/7.5	4.1-3.6/1.8	11.8/5.9	1.4
10-05	1.5	1.12	4.9-4.6/2.3	12.8/6.4	4.9-4.6/2.3	16.0/8.0	1.8
10-06	1.5	1.12	4.9-4.6/2.3	12.8/6.4	4.9-4.6/2.3	16.0/8.0	1.8
10-07	2	1.49	6.2-5.8/2.9	26.0/13.0	6.2-5.8/2.9	23.0/11.5	2.2
10-08	2	1.49	6.2-5.8/2.9	26.0/13.0	6.2-5.8/2.9	23.0/11.5	2.2
10-09	3	2.24	8.5-8.0/4.0	–	8.1-7.6/3.8	–	3.0
10-10	3	2.24	8.5-8.0/4.0	–	8.1-7.6/3.8	–	3.0
10-12	3	2.24	8.5-8.0/4.0	–	8.1-7.6/3.8	–	3.0
10-14	5	3.73	13.1-11.5/5.7	–	13.2-12.0/6.0	–	4.8
10-16	5	3.73	13.1-11.5/5.7	–	13.2-12.0/6.0	–	4.8
15-02	1	0.75	4.1-3.6/1.8	15.0/7.5	4.1-3.6/1.8	11.8/5.9	1.4
15-03	1	0.75	4.1-3.6/1.8	15.0/7.5	4.1-3.6/1.8	11.8/5.9	1.4
15-04	1.5	1.12	4.9-4.6/2.3	12.8/6.4	4.9-4.6/2.3	16.0/8.0	1.8
15-05	2	1.49	6.2-5.8/2.9	26.0/13.0	6.2-5.8/2.9	23.0/11.5	2.2
15-06	2	1.49	8.5-8.0/4.0	26.0/13.0	8.1-7.6/3.8	23.0/11.5	3.0
15-07	3	2.24	8.5-8.0/4.0	–	8.1-7.6/3.8	–	3.0
15-08	3	2.24	8.5-8.0/4.0	–	8.1-7.6/3.8	–	3.0
15-10	5	3.73	13.1-11.5/5.7	–	13.2-12.0/6.0	–	4.8
15-12	5	3.73	13.1-11.5/5.7	–	13.2-12.0/6.0	–	4.8
15-14	5	3.73	13.1-11.5/5.7	–	13.2-12.0/6.0	–	4.8
30-02	1	0.75	4.1-3.6/1.8	15.0/7.5	4.1-3.6/1.8	11.8/5.9	1.4
30-03	1.5	1.12	4.9-4.6/2.3	12.8/6.4	4.9-4.6/2.3	16.0/8.0	1.8
30-04	2	1.49	6.2-5.8/2.9	26.0/13.0	6.2-5.8/2.9	23.0/11.5	2.2
30-05	3	2.24	8.5-8.0/4.0	–	8.1-7.6/3.8	–	3.0
30-06	3	2.24	8.5-8.0/4.0	–	8.1-7.6/3.8	–	3.0
30-07	5	3.73	13.1-11.5/5.7	–	13.2-12.0/6.0	–	4.8
30-08	5	3.73	13.1-11.5/5.7	–	13.2-12.0/6.0	–	4.8
30-10	7.5	5.59	19-18/9	–	19.0-17.2/8.6	–	7.0
30-12	7.5	5.59	19-18/9	–	19.0-17.2/8.6	–	7.0
30-14	7.5	5.59	19-18/9	–	19.0-17.2/8.6	–	7.0
50-02	2	1.49	6.2-5.8/2.9	26.0/13.0	6.2-5.8/2.9	23.0/11.5	2.2
50-03	3	2.24	8.5-8.0/4.0	–	8.1-7.6/3.8	–	3.0
50-04	5	3.73	13.1-11.5/5.7	–	13.2-12.0/6.0	–	4.8
50-05	5	3.73	13.1-11.5/5.7	–	13.2-12.0/6.0	–	4.8
50-06	7.5	5.59	19-18/9	–	19.0-17.2/8.6	–	7.0
50-07	7.5	5.59	19-18/9	–	19.0-17.2/8.6	–	7.0
50-08	7.5	5.59	19-18/9	–	19.0-17.2/8.6	–	7.0

# High pressure centrifugal pumps

Wilo-Multivert MVI (North America)



## Motor Data Wilo-Multivert MVI

Motor Data							
Wilo-Multivert MVI ...	Rated power output		Full Load Current				
	P <sub>2</sub>		I (ODP motor enclosure)		I (TEFC motor enclosure)		
			3~208-230/460 60 Hz	1~115/230 60 Hz	3~208-230/460 60 Hz	1~115/230 60 Hz	3~575 60 Hz
	[hp]	[kW]	[A]	[A]	[A]	[A]	[A]
50-10	10	7.46	25.6-23.2/11.6	–	26.2-23.8/11.9	–	9,2
50-11	10	7.46	25.6-23.2/11.6	–	26.2-23.8/11.9	–	9,2
80-02	3	2.24	8.5-8.0/4.0	–	8.1-7.6/3.8	–	3,0
80-03	5	3.73	13.1-11.5/5.7	–	13.2-12.0/6.0	–	4,8
80-04	7.5	5.59	19-18/9	–	19.0-17.2/8.6	–	7,0
80-05	7.5	5.59	19-18/9	–	19.0-17.2/8.6	–	7,0
80-06	10	7.46	25.6-23.2/11.6	–	26.2-23.8/11.9	–	9,2

# High pressure centrifugal pumps

Wilo-Multivert MVI (North America)

## Dimension drawings Wilo-Multivert MVI

### Dimension drawings

Wilo-Multivert MVI 10..., 15..., 30...

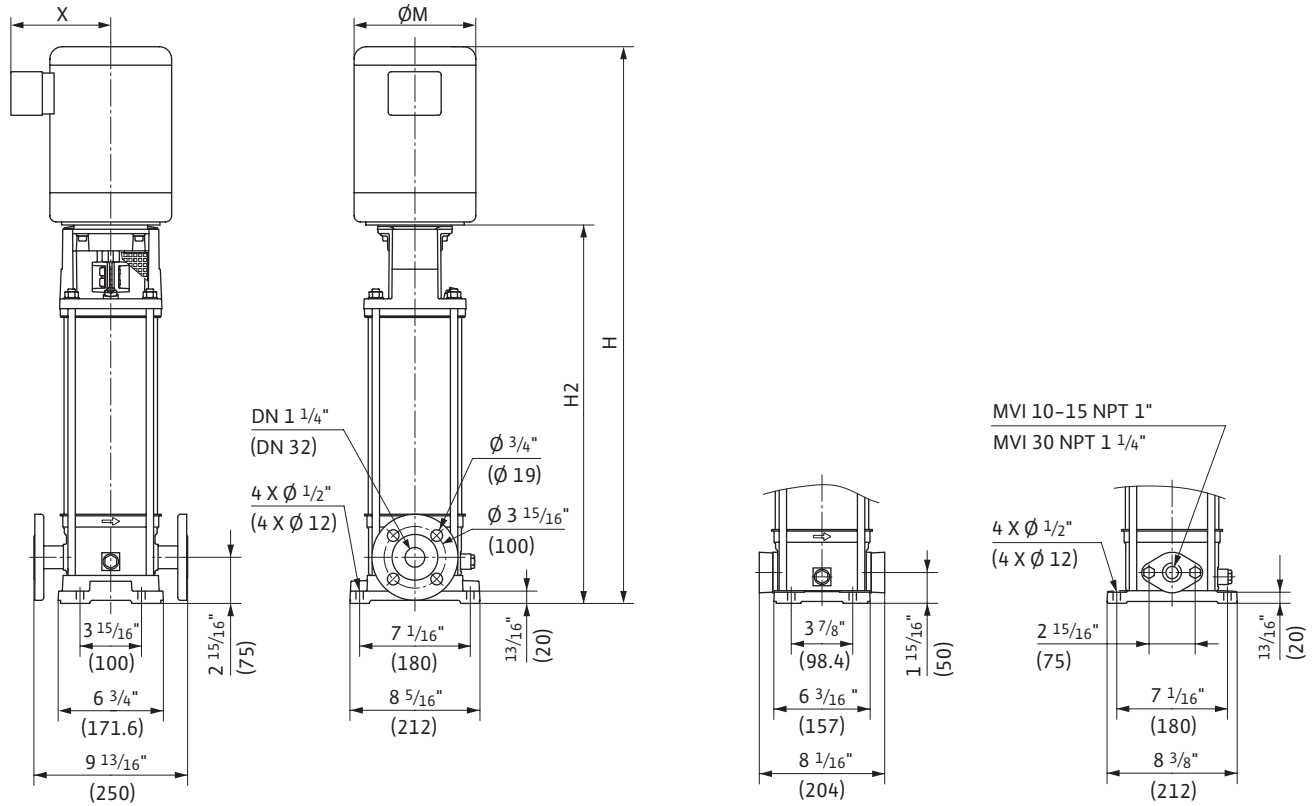

# High pressure centrifugal pumps

Wilo-Multivert MVI (North America)



## Dimension drawings Wilo-Multivert MVI

### Dimension drawings

Wilo-Multivert MVI 50..., 80...

MVI 50/80

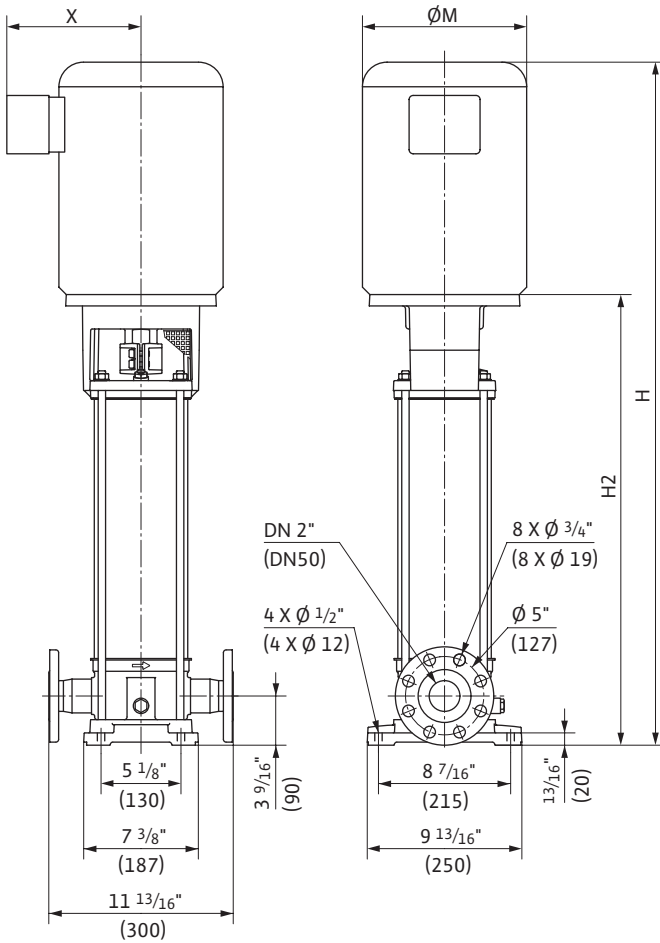

MVI 50 NPT 1 1/2"

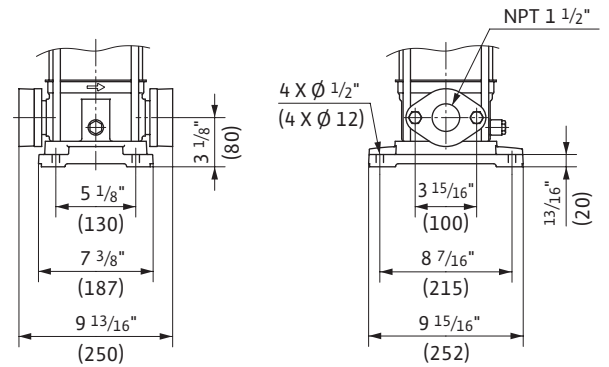

MVI 80 NPT 2"

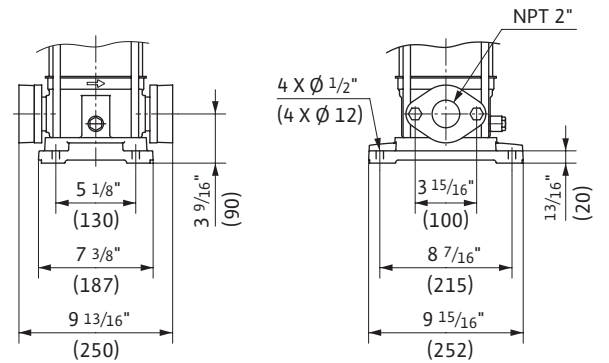

# High pressure centrifugal pumps

## Wilo-Multivert MVI (North America)

### Dimensions, Weights Wilo-Multivert MVI

Dimensions, Weights										
Wilо-Multivert MVI ...	Dimensions								Net weight	
	H		H <sub>2</sub>		M		X		-	
	[in]	[mm]	[in]	[mm]	[in]	[mm]	[in]	[mm]	[lb]	[kg]
10-02	24 1/4	616	13 15/16	354	6 3/16	157	5 3/16	132	61	27.7
10-03	24 1/4	616	13 15/16	354	6 3/16	157	5 3/16	132	61.2	27.8
10-04	26 3/8	670	13 15/16	354	7 3/16	183	5 3/4	146	69.5	31.5
10-05	28	710	14 3/4	374	7 3/16	183	5 3/4	146	74.8	33.9
10-06	28	710	15 1/2	394	7 3/16	183	5 3/4	146	75.3	34.2
10-07	28 3/4	730	16 5/16	414	7 3/16	183	5 3/4	146	90.7	41.1
10-08	30 5/16	770	17 7/8	454	7 3/16	183	5 3/4	146	93.3	42.3
10-09	31 5/16	795	17 7/8	454	7 3/16	183	5 3/4	146	85.3	38.7
10-10	32 1/8	815	18 11/16	474	7 3/16	183	5 3/4	146	89.3	40.5
10-12	33 11/16	855	20 1/4	514	7 3/16	183	5 3/4	146	93.9	42.6
10-14	36	915	20 9/16	523	8 1/2	216	6 7/8	174	131.2	59.5
10-16	38	965	22 9/16	573	8 1/2	216	6 7/8	174	134.3	60.9
15-02	24 7/8	632	13 5/8	345.5	6 3/16	157	5 3/16	132	56.6	25.7
15-03	26 1/16	662	13 5/8	345.5	7 3/16	183	5 3/4	146	63.6	28.8
15-04	27	686	14 9/16	369.5	7 3/16	183	5 3/4	146	68.9	31.3
15-05	27 15/16	710	15 1/2	393.5	7 3/16	183	5 3/4	146	82.3	37.3
15-06	29 7/8	759	16 7/16	417.5	7 3/16	183	5 3/4	146	84.5	38.3
15-07	30 13/16	783	17 3/8	441.5	7 3/16	183	5 3/4	146	81.8	37.1
15-08	31 3/8	797	17 15/16	455.5	7 3/16	183	5 3/4	146	83.1	37.7
15-10	36 3/8	924	20 15/16	532.5	8 1/2	216	6 7/8	174	120	54.4
15-12	38 1/4	972	22 7/8	580.5	8 1/2	216	6 7/8	174	123.9	56.2
15-14	40 3/16	1020	24 3/4	628.5	8 1/2	216	6 7/8	174	126.8	57.5
30-02	25 11/16	652	13 3/16	335.5	7 3/16	183	5 3/4	146	67.3	30.5
30-03	26 1/16	662	13 5/8	345.5	7 3/16	183	5 3/4	146	67.6	30.7
30-04	27	686	14 9/16	369.5	7 3/16	183	5 3/4	146	81	36.7
30-05	28 15/16	735	15 1/2	393.5	7 3/16	183	5 3/4	146	79.2	35.9
30-06	29 7/8	759	16 7/16	417.5	7 3/16	183	5 3/4	146	80.5	36.5
30-07	33 9/16	852	18 1/8	460.5	8 1/2	216	6 7/8	174	116	52.6
30-08	34 1/2	876	19 1/16	484.5	8 1/2	216	6 7/8	174	117.3	53.2
30-10	38 7/8	987	20 15/16	532.5	10 1/4	261	8 1/16	204	138.8	63.0
30-12	40 3/4	1035	22 7/8	580.5	10 1/4	261	8 1/16	204	151.1	68.5
30-14	42 5/8	1083	24 3/4	628.5	10 1/4	261	8 1/16	204	153.8	69.8
50-02	27 1/8	689	14 1/16	357.5	7 3/16	183	5 3/4	146	84.3	38.2
50-03	28 11/16	729	15 1/4	387.5	7 3/16	183	5 3/4	146	80.7	36.6
50-04	32 5/8	829	17 3/16	436.5	8 1/2	216	6 7/8	174	116.2	52.7
50-05	33 13/16	859	18 3/8	466.5	8 1/2	216	6 7/8	174	117.7	53.4
50-06	37 7/16	951	19 9/16	496.5	10 1/4	261	8 1/16	204	146.4	66.4
50-07	38 5/8	981	20 3/4	526.5	10 1/4	261	8 1/16	204	147.9	67.1
50-08	39 13/16	1011	21 15/16	556.5	10 1/4	261	8 1/16	204	149.5	67.8
50-10	42 9/16	1081	24 5/8	626	10 1/4	261	8 1/16	204	179.8	81.6
50-11	45 3/16	1148	27	686	10 1/4	261	8 1/16	204	182.9	83.0
80-02	29 3/16	742	15 3/4	400.5	7 3/16	183	5 3/4	146	82.9	37.6
80-03	32 3/8	822	16 15/16	430.5	8 1/2	216	6 7/8	174	119.7	54.3
80-04	36 5/16	923	18 7/16	468.5	10 1/4	261	8 1/16	204	149.3	67.7
80-05	37 13/16	961	19 15/16	506.5	10 1/4	261	8 1/16	204	151.9	68.9
80-06	40	1016	21 13/16	554	10 1/4	261	8 1/16	204	179.8	81.6