

Submittal Data Sheet

Wilo-Stratos GIGA - High-Efficiency In-Line Pumps

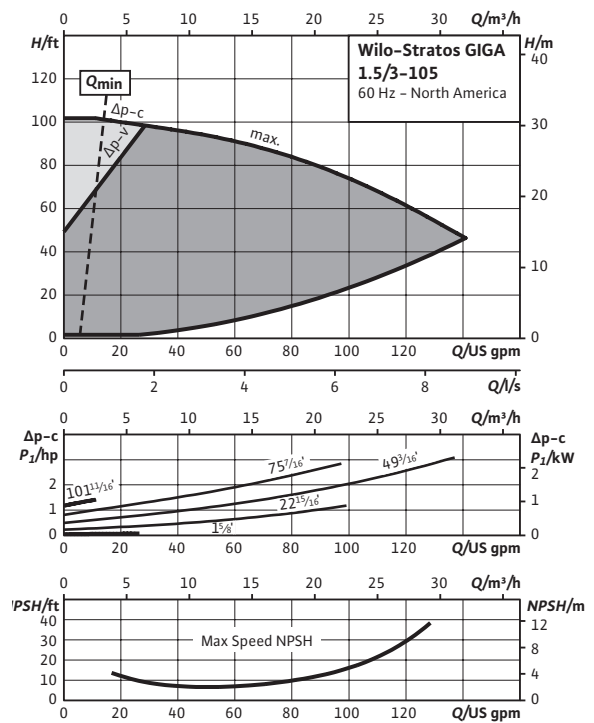

Wilo-Stratos GIGA 1.5/3-105							
		Project:					
		Engineer:					
		Contractor:					
		Submitted By:			Date:		
		Approved By:			Date:		
Tag #	Model #	Flow	Head	Control Mode	Cycle	Phase	Voltage
	Wilo-Stratos GIGA 1.5/3-105					3	460

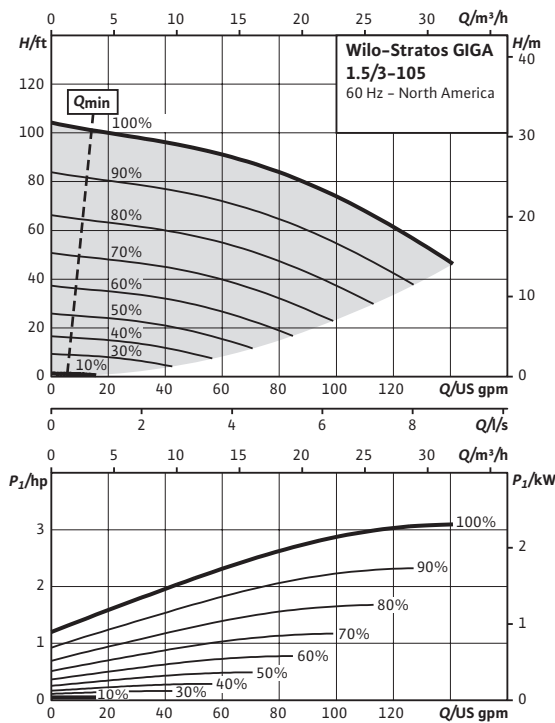

Technical Data	
Liquid Temp Range	-4°F to 248°F (-20°C to +120°C)
Fluid Capability	Water 50/50 Water-Glycol Mixtures
Max Operating Pressure	232 PSI 248°F (water only) 194°F (50% propylene)
Mains Voltage	3- 380-480V ±10% 50/60Hz
Protection Class	IP 55, Class F Insulation
Ambient Temp Range	32°F to 104°F (0°C to 40°C)
Max Relative Humidity	32°F to 86°F (0°C to 30°C): 90% 87°F to 104°F (31°C to 40°C): 60%
Sound Level	< 74 dBA

Materials of Construction	
Pump Volute	Cast Iron Cataphoresis Coated (ASTM A48 / EN-GJL-250)
Impeller	Composite (PPS-GF40) Integral Stainless Inlet
Shaft	Stainless Steel (AISI 420 / 1.4122)
Mechanical Seal	SiC/SiC-NBR (Q7Q7X4GG)

IR Module Selection		
Module 1	Module	Article Number
	BACnet / Dual Pump	2097811
	LONworks / Dual Pump	2022530
	MODBus	2097809
	None	None

Applications	
• Hot Water Heating Systems	• Closed Cooling Circuits
• Industrial Circulation Systems	• Air-conditioning Systems
• Solar	• Geothermal

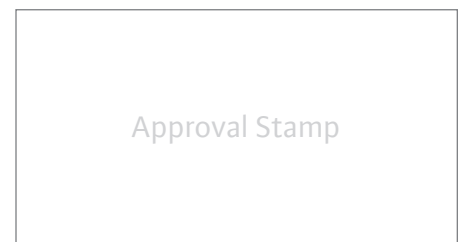

Submittal Data Sheet

Wilo-Stratos GIGA - High-Efficiency In-Line Pumps



Dimensions & Weights

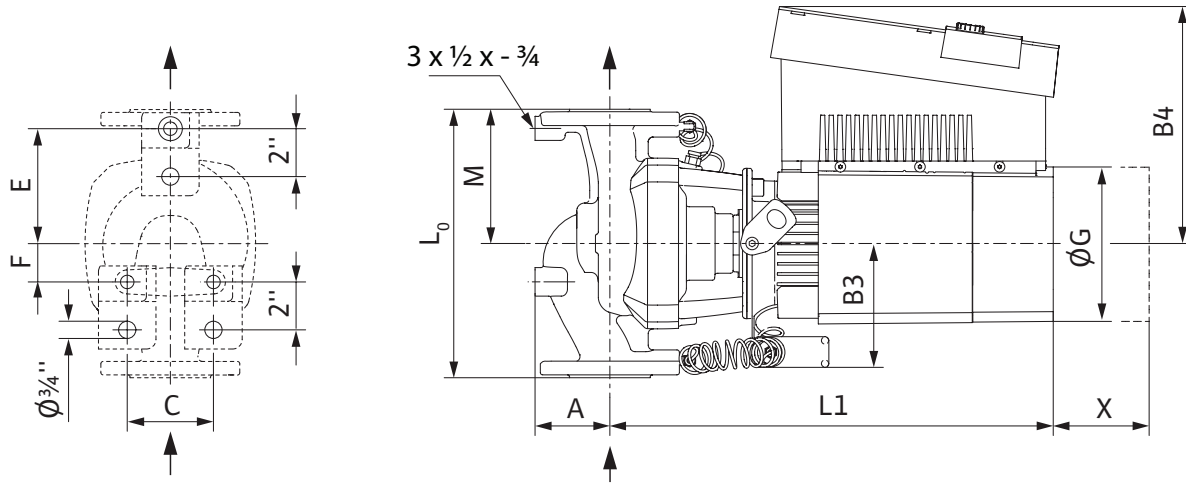

Dimensions and Weights

Model	Dimensions - Inches (mm)														Weight lbs (kg)
	I ₀	A	B1	B2	B3	B4	C	E	F	ØG	H	L1	M	X	
Wilo-Stratos GIGA 1.5/3-105	11½ (292)	3¾ (86)	3½ (89)	3½ (89)	5 ¹ / ₁₆ (129)	9¼ (248)	3 ⁵ / ₈ (92)	4 ⁷ / ₈ (124)	1 ⁵ / ₈ (41)	6 ⁵ / ₈ (168)	10 ⁷ / ₈ (277)	18¼ (463)	5½ (140)	8 ⁷ / ₈ (225)	89 (41)

Flange Dimensions - 125#ANSI

Dimensions - Inches (mm)				
Dia.	ØD	Ød	Øk	n x Ød _L
1.5"	6 ¹ / ₈ (155)	3 ⁹ / ₁₆ (90)	3 ⁷ / ₈ (99)	4 x 5/8 (4 x 16)

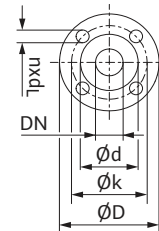

EC Motor Data (Single Motor Operation)

Model	P ₂ Rated	P ₁	Speed	FLA
	hp	kW	RPM	3~480V
Wilo-Stratos GIGA 1.5/3-105	3.1	2.3	500-4500	3.0 A

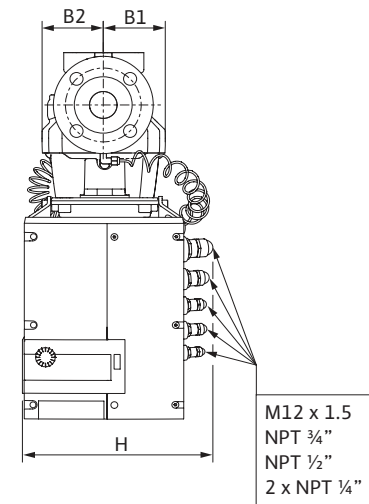
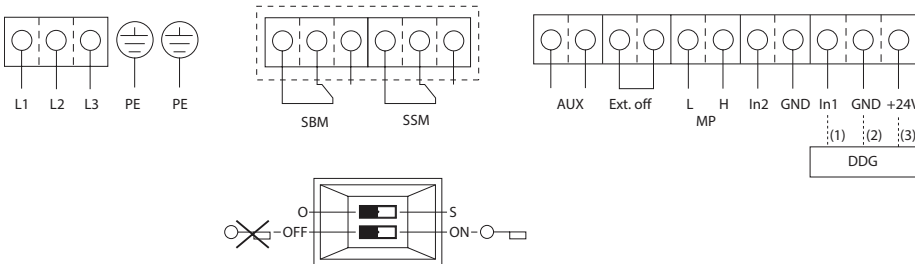

Wilo USA

T +1 888 945 6872
F +1 888 945 6873
www.wilo-usa.com
info@wilo-usa.com

Wilo Canada Inc.

T +1 866 945 6236
F +1 403 277 9456
www.wilo-canada.com
info@wilo-canada.com

Wilo Mexico

T +52 55 5586 3209
F +52 1 55 5413 4165
www.wilo-mexico.com.mx
info@wilo.com.mx