

Submittal Data Sheet

Wilo-Stratos GIGA - High-Efficiency In-Line Pumps



Wilo-Stratos GIGA 2/3-85



| | |
|---------------|-------|
| Project: | |
| Engineer: | |
| Contractor: | |
| Submitted By: | Date: |
| Approved By: | Date: |

| Tag # | Model # | Flow | Head | Control Mode | Cycle | Phase | Voltage |
|-------|--------------------------|------|------|--------------|-------|-------|---------|
| | Wilo-Stratos GIGA 2/3-85 | | | | | 3 | 460 |

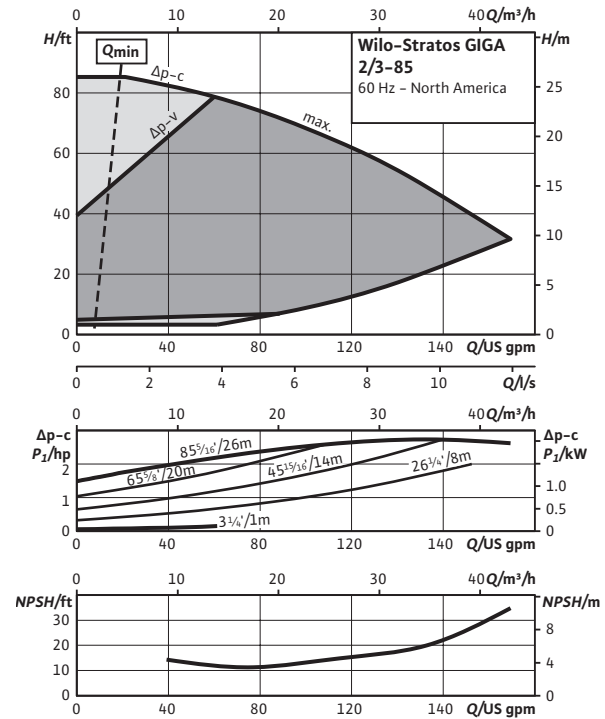
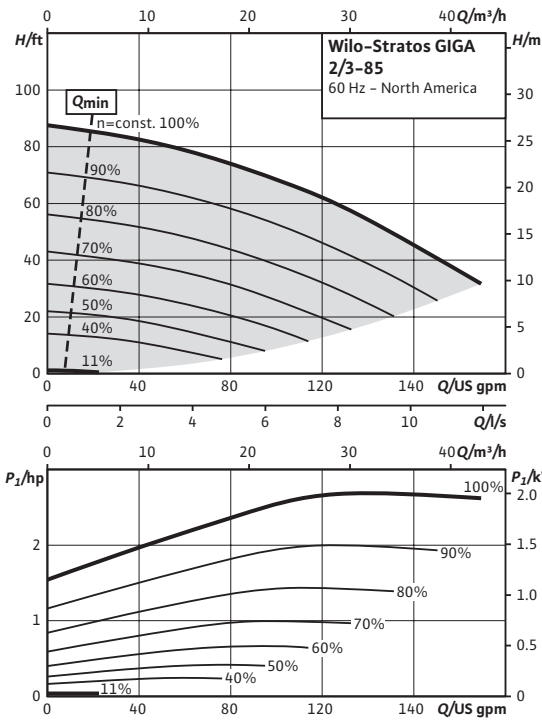

| Technical Data | |
|------------------------|--|
| Liquid Temp Range | -4°F to 248°F (-20°C to +120°C) |
| Fluid Capability | Water 50/50 Water-Glycol Mixtures |
| Max Operating Pressure | 232 PSI 248°F (water only) 194°F (50% propylene) |
| Mains Voltage | 3- 380-480V ±10% 50/60Hz |
| Protection Class | IP 55, Class F Insulation |
| Ambient Temp Range | 32°F to 104°F (0°C to 40°C) |
| Max Relative Humidity | 32°F to 86°F (0°C to 30°C): 90% 87°F to 104°F (31°C to 40°C): 60% |
| Sound Level | < 74 dBA |

| Materials of Construction | |
|---------------------------|---|
| Pump Volute | Cast Iron Cataphoresis Coated (ASTM A48 / EN-GJL-250) |
| Impeller | Composite (PPS-GF40) Integral Stainless Inlet |
| Shaft | Stainless Steel (AISI 420 / 1.4122) |
| Mechanical Seal | SiC/SiC-NBR (Q7Q7X4GG) |

| IR Module Selection | | |
|---------------------|----------------------|----------------|
| Module 1 | Module | Article Number |
| | BACnet / Dual Pump | 2097811 |
| | LONworks / Dual Pump | 2022530 |
| | MODBus | 2097809 |
| | None | None |

| Applications | |
|----------------------------------|----------------------------|
| • Hot Water Heating Systems | • Closed Cooling Circuits |
| • Industrial Circulation Systems | • Air-conditioning Systems |
| • Solar | • Geothermal |

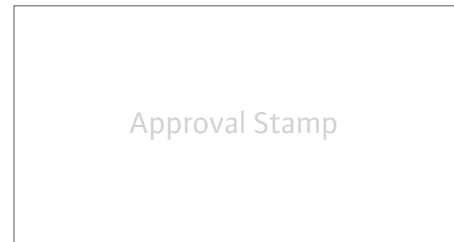

Submittal Data Sheet

Wilo-Stratos GIGA - High-Efficiency In-Line Pumps



Dimensions & Weights

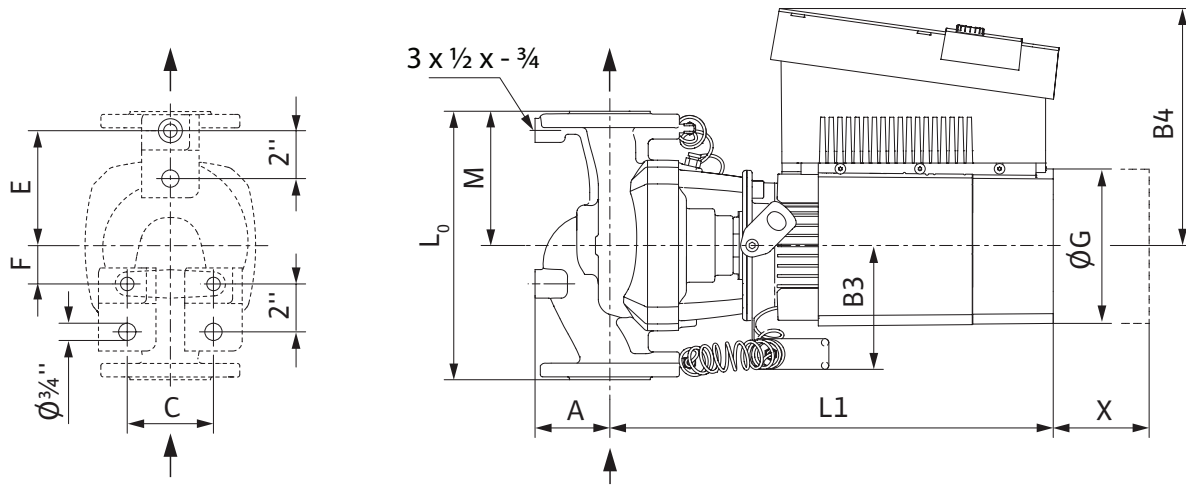

Dimensions and Weights

| Model | Dimensions - Inches (mm) | | | | | | | | | | | | | | Weight lbs (kg) |
|-----------------------------|--------------------------|------|------|------|--------------------------------|-------|-------------------------------|-------------------------------|-------------------------------|-------------------------------|--------------------------------|--------------------------------|-------|-------------------------------|--------------------|
| | I ₀ | A | B1 | B2 | B3 | B4 | C | E | F | ØG | H | L1 | M | X | |
| Wilo-Stratos GIGA 2/3-85 | 12 | 3½ | 3½ | 3½ | 5 ³ / ₁₆ | 9¾ | 3 ⁵ / ₈ | 4 ⁷ / ₈ | 1 ⁵ / ₈ | 6 ⁵ / ₈ | 10 ⁷ / ₈ | 18 ¹ / ₈ | 5½ | 8 ⁷ / ₈ | 93 |
| | (305) | (89) | (89) | (89) | (129) | (248) | (92) | (124) | (41) | (168) | (277) | (460) | (140) | (225) | (42) |

Flange Dimensions - 125#ANSI

| Dimensions - Inches (mm) | | | | |
|--------------------------|-------|--------------------------------|-------|---------------------|
| Dia. | ØD | Ød | Øk | n x Ød _L |
| 2" | 6½ | 4 ³ / ₁₆ | 4¾ | 4 x ¾ |
| | (165) | (106) | (121) | (4 x 19) |

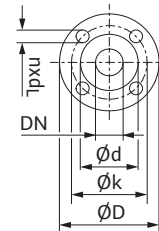

EC Motor Data (Single Motor Operation)

| Model | P ₂ Rated | P ₁ | Speed | FLA |
|--------------------------|----------------------|----------------|----------|--------|
| | hp | kW | RPM | 3~480V |
| Wilo-Stratos GIGA 2/3-85 | 2.7 | 2 | 500-4450 | 2.6 |

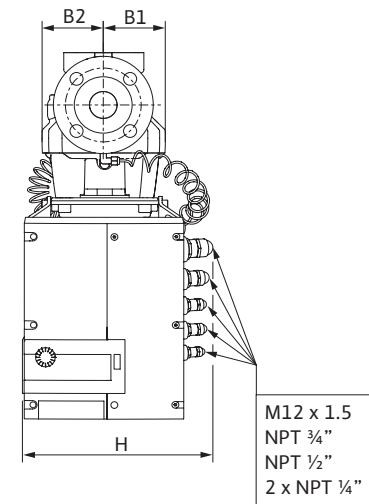
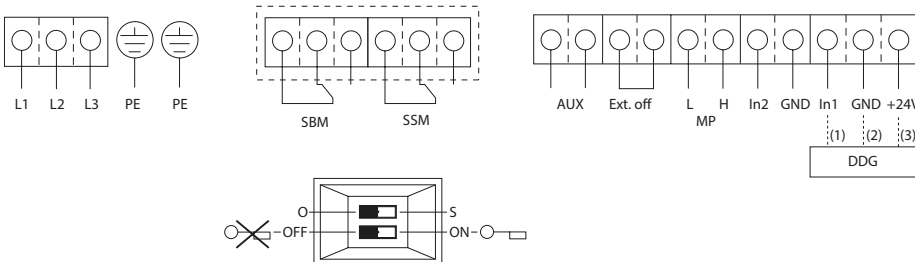

Wilo USA

T +1 888 945 6872
F +1 888 945 6873
www.wilo-usa.com
info@wilo-usa.com

Wilo Canada Inc.

T +1 866 945 6236
F +1 403 277 9456
www.wilo-canada.com
info@wilo-canada.com

Wilo Mexico

T +52 55 5586 3209
F +52 1 55 5413 4165
www.wilo-mexico.com.mx
info@wilo.com.mx