

# Submittal Data Sheet

## Wilco-Stratos GIGA - High-Efficiency In-Line Pumps



### Wilo-Stratos GIGA 4/3-105



Project:	
Engineer:	
Contractor:	
Submitted By:	Date:
Approved By:	Date:

Tag #	Model #	Flow	Head	Control Mode	Cycle	Phase	Voltage
	Wilo-Stratos GIGA 4/3-105					3	460

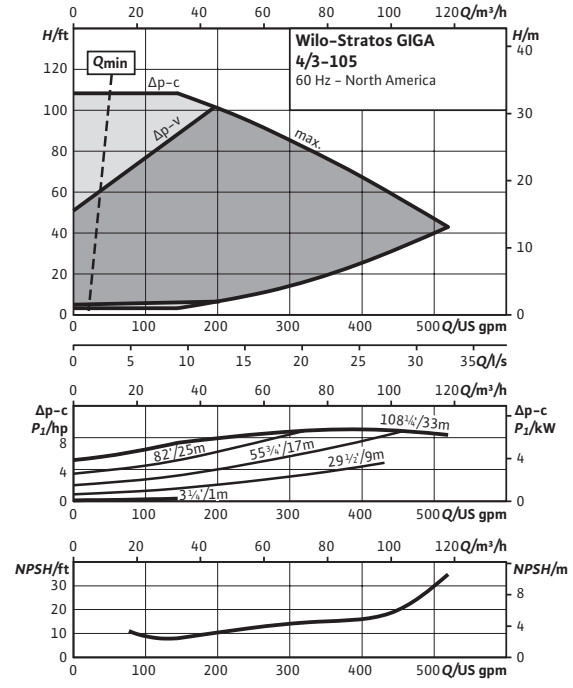
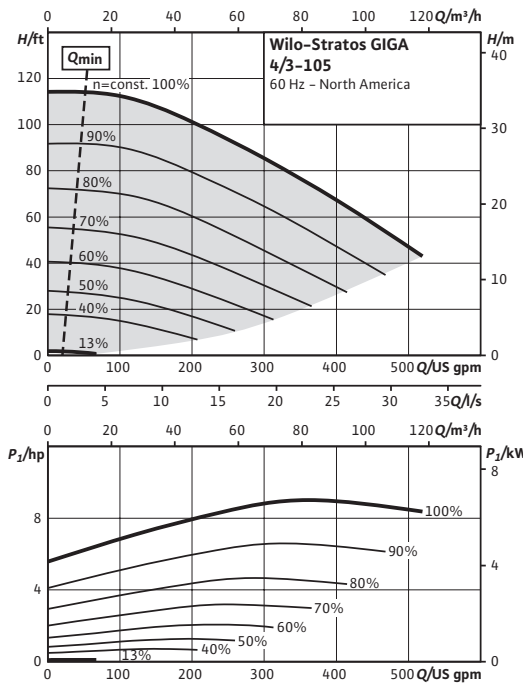

Technical Data	
Liquid Temp Range	-4°F to 248°F (-20°C to +120°C)
Fluid Capability	Water 50/50 Water-Glycol Mixtures
Max Operating Pressure	232 PSI 248°F (water only) 194°F (50% propylene)
Mains Voltage	3- 380-480V ±10% 50/60Hz
Protection Class	IP 55, Class F Insulation
Ambient Temp Range	32°F to 104°F (0°C to 40°C)
Max Relative Humidity	32°F to 86°F (0°C to 30°C): 90% 87°F to 104°F (31°C to 40°C): 60%
Sound Level	< 74 dBA

Materials of Construction	
Pump Volute	Cast Iron Cataphoresis Coated (ASTM A48 / EN-GJL-250)
Impeller	Composite (PPS-GF40) Integral Stainless Inlet
Shaft	Stainless Steel (AISI 420 / 1.4122)
Mechanical Seal	SiC/SiC-NBR (Q7Q7X4GG)

Applications	
• Hot Water Heating Systems	• Closed Cooling Circuits
• Industrial Circulation Systems	• Air-conditioning Systems
• Solar	• Geothermal

IR Module Selection		
Module 1	Module	Article Number
	BACnet / Dual Pump	2097811
	LONworks / Dual Pump	2022530
	MODBus	2097809
	None	None

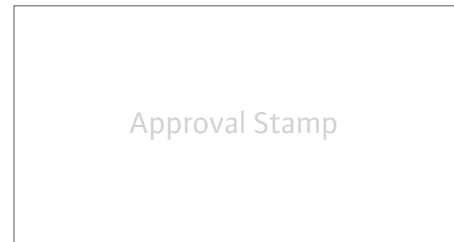

# Submittal Data Sheet

Wilo-Stratos GIGA - High-Efficiency In-Line Pumps



## Dimensions & Weights

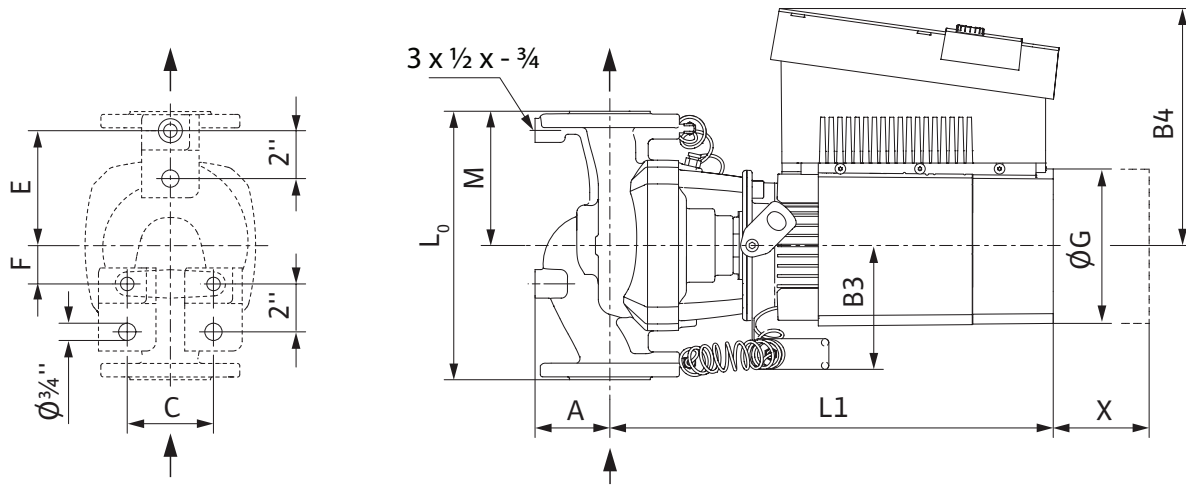

## Dimensions and Weights

Model	Dimensions - Inches (mm)														Weight lbs (kg)
	I <sub>0</sub>	A	B1	B2	B3	B4	C	E	F	ØG	H	L1	M	X	
Wilo-Stratos GIGA 4/3-105	19 (482)	5½ (140)	5 (127)	5 <sup>9</sup> / <sub>16</sub> (141)	5 <sup>1</sup> / <sub>16</sub> (129)	11 (279)	5½ (140)	8½ (216)	3½ (89)	7 <sup>13</sup> / <sub>16</sub> (198)	10 <sup>7</sup> / <sub>8</sub> (276)	21 <sup>9</sup> / <sub>16</sub> (548)	9½ (241)	11 <sup>13</sup> / <sub>16</sub> (300)	185 (84)

## Flange Dimensions - 125#ANSI

Dimensions - Inches (mm)				
Dia.	ØD	Ød	Øk	n x Ød <sub>L</sub>
4"	10 (254)	6 <sup>15</sup> / <sub>16</sub> (176)	7½ (191)	8 x ¾ (8 x 19)

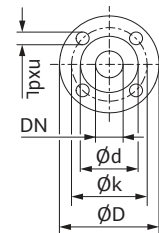

## EC Motor Data (Single Motor Operation)

Model	P <sub>2</sub> Rated	P <sub>1</sub>	Speed	FLA
	hp	kW	RPM	3~480V
Wilo-Stratos GIGA 4/3-105	9.1	6.8	500-2300	8.5

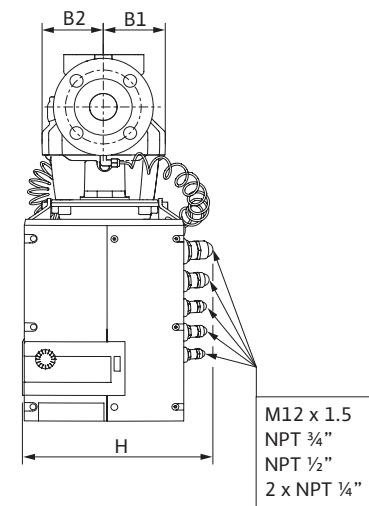
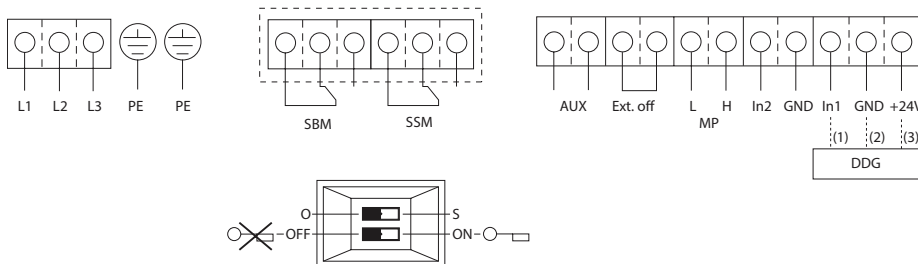

Wilo USA

T +1 888 945 6872  
F +1 888 945 6873  
www.wilo-usa.com  
info@wilo-usa.com

Wilo Canada Inc.

T +1 866 945 6236  
F +1 403 277 9456  
www.wilo-canada.com  
info@wilo-canada.com

Wilo Mexico

T +52 55 5586 3209  
F +52 1 55 5413 4165  
www.wilo-mexico.com.mx  
info@wilo.com.mx