

Submittal Data Sheet

Wilo-SIBOOSTER EXCEL - NSF 61/372 Pressure Boosting System



SIBOOSTER-2 EXCEL V50-07-1/5.7/VCE

	Project:							
	Engineer:							
	Contractor:							
	Submitted By:				Date:			
	Approved By:				Date:			
Tag #	Model #	Flow	BOOST PSI	Min. Inlet PSI	HP/Pump	Phase	Voltage	RPM
	SIBOOSTER-2 EXCEL V50-07-1/5.7/VCE				5.7			3600

Article Number: 2701003

SiBoost 2 EXCEL 50-07

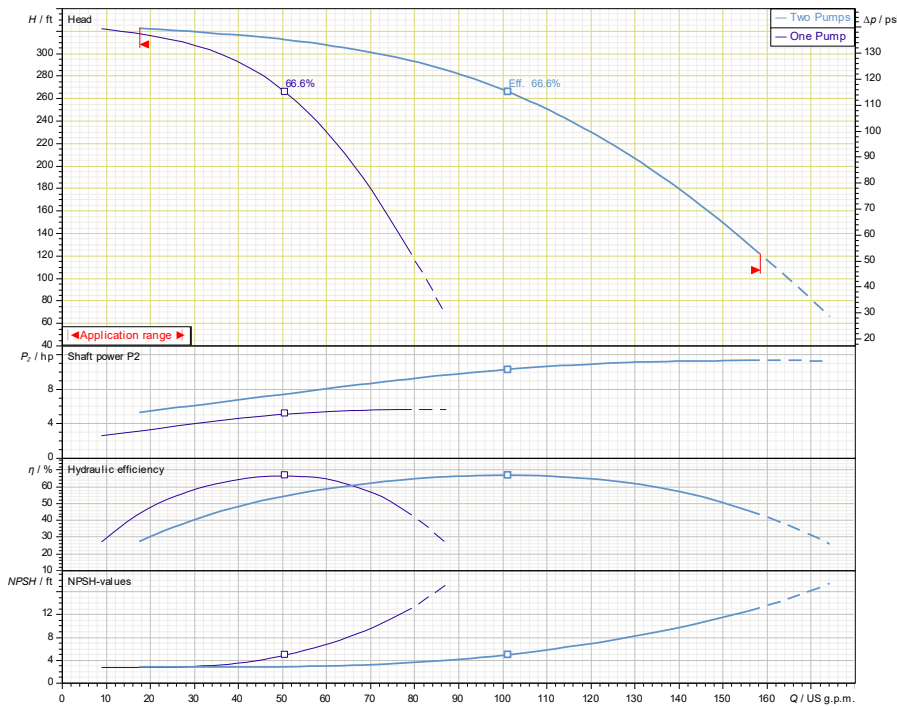

Applications

- Water Supply
- Pressure Boosting
- Agriculture
- Cooling Circuits
- Washing / Sprinkling Systems
- Condensate Return

Materials of Construction

Pump Volute	AISI304 stainless steel with ANSI flanges
Impeller	3D Laser welded AISI 304 Stainless Steel
Shaft	AISI304, AISI318 LN, or AISI431 Stainless Steel
Elastomers	EPDM
Isolation Valves	304 Stainless Steel Ball Valves
Suction/Discharge Manifolds	AISI304 Stainless Steel with Male Threaded System Connections
Check Valves	Wafer Style, 316 Stainless Steel internals, Non-slam, Plunger-type with EPDM seal/ Cast Iron Body
Mechanical Seal	Cartridge Seal: Sleeve AISI316L / Spring Clips AISI304
Pressure Transducers	316 Stainless Steel
Pressure Guages	304 Stainless Steel Housing with 316 Stainless Steel wetted parts
System base	Steel (S235JR)
Vibration Isolators	Neoprene, Height Adjustable

Technical Data - Operational Ranges

Liquid Temp Range	-4°F to +248°F (Min. 32 °F for Domestic Water)
Ambient Temp Range	+32°F to +104 °F
Max Inlet Pressure	145 PSI
Max System Pressure	232 PSI/363 PSI

Technical Data - Panel

Power Supply	460v~3
Enclosure	NEMA 12 (3R Available Upon Request)
Standard	Meets UL 508A

Technical Data - PLC

User Interface	7" Diagonal Color LCD Touchscreen
Display Resolution	800 x 480 Pixels
Supply Voltage	24VDC
Max. Current Consumption	320mA@24V
Number of Analog Inputs	9
Number of Analog Outputs	2
Number of Digital Inputs	18
Number of Digital Outputs	17
Onboard Communications	Modbus Protocol (Optional Gateways for BacNET, LonWorks, and CANbus)
Ethernet Port	RJ45 port capable of transmitting data 10/100Mbps
Additional Ports	2.0 USB Port; Micro-SD Port

Motor Data

Power Supply	460V~3
Motor Enclosure	Totally Enclosed Fan Cooled (TEFC)
Motor Efficiency	IEC Premium Efficiency (IE5) - Electronically Commutated Motor (EC Motor with Powerhead control)
Enclosure Construction	Cast Iron
Motor Protection Index	IP55
Insulation Class	F

Approval Stamp

Submittal Data Sheet

Wilo-SIBOOSTER EXCEL - NSF 61/372 Pressure Boosting System



SIBOOSTER-2 EXCEL V50-07-1/5.7/VCE

460 V~3

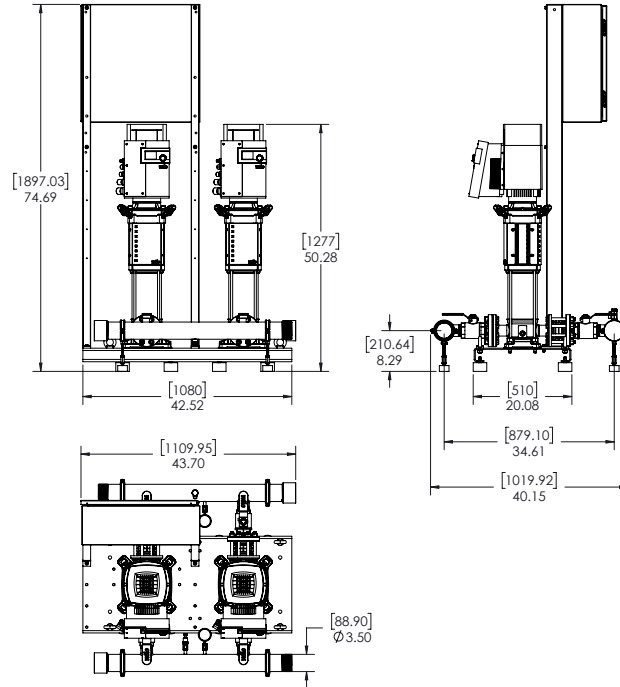

Special Note: All weights and dimensions are approximate and should not be used as exact rough-in dimensions

Dimensions and Weights

Model	Voltage (V)	Dimensions-inches							Hydrnumatic Tank Valve on Manifold (Plugged)	Individual Pump Weight Pump Weight (lbs)	Package Weight (lbs)
		H (in)	W (in)	L (in)	System Header Size	Suction / Discharge Pump Size (300 Class ANSI)	Gauge Tap Size	Transducer Tap Size			
SIBOOSTER-2 EXCEL V50-07-1/5.7/VCE	460 V	74-3/4	43-3/4	40-1/8	3" MNPT	2"	1/4" FNPT	1/4" FNPT	3/4" MNPT x 3/4" FNPT	154	588

EC Motor Data (Single Motor Operation)

Model	P2 (HP)	Phase (-)	Voltage (V)	FLA (per pump) (A)	Efficiency ηm 100%	Pmax (PSI)
SIBOOSTER-2 EXCEL V50-07-1/5.7/VCE	5.7	3	460 (±10%)	6.5	95.8	232