

# Submittal Data Sheet

Wilo-SIBOOSTER EXCEL - NSF 61/372 Pressure Boosting System



## SIBOOSTER-4 EXCEL V270-02-1/10.1/VCE



|               |       |
|---------------|-------|
| Project:      |       |
| Engineer:     |       |
| Contractor:   |       |
| Submitted By: | Date: |
| Approved By:  | Date: |

| Tag # | Model #                              | Flow | BOOST PSI | Min. Inlet PSI | HP/Pump | Phase | Voltage | RPM  |
|-------|--------------------------------------|------|-----------|----------------|---------|-------|---------|------|
|       | SIBOOSTER-4 EXCEL V270-02-1/10.1/VCE |      |           |                | 10.1    |       |         | 3600 |

### Article Number: 2701077

#### SIBOOSTER 4 EXCEL 270-02/1

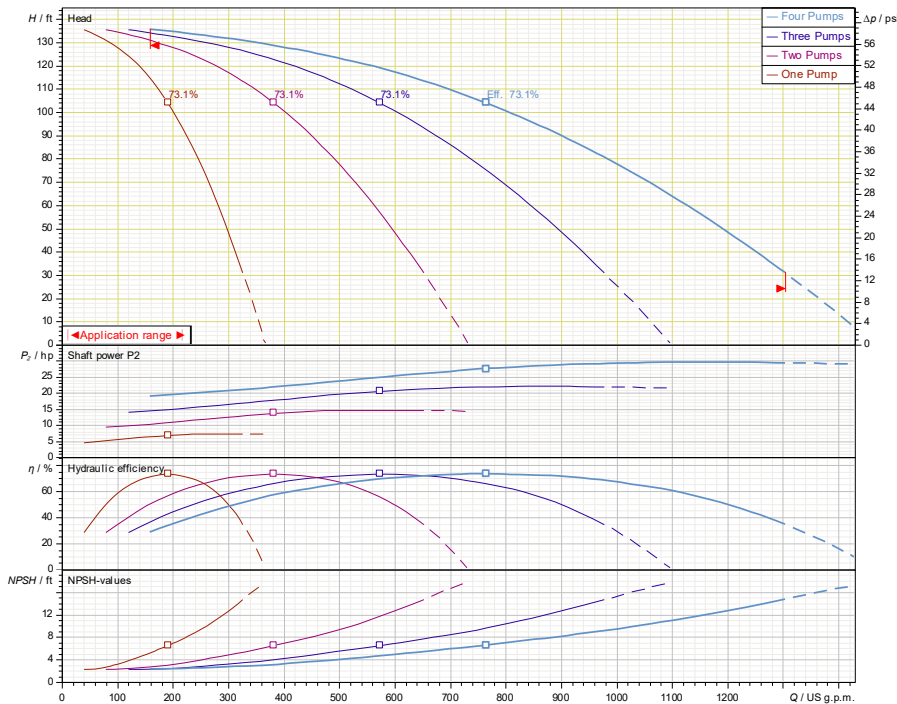

### Applications

- Water Supply
- Pressure Boosting
- Agriculture
- Cooling Circuits
- Washing / Sprinkling Systems
- Condensate Return

### Materials of Construction

|                             |   |
|-----------------------------|---|
| Pump Volute                 | AISI304 stainless steel with ANSI flanges   |
| Impeller                    | 3D Laser welded AISI 304 Stainless Steel  |
| Shaft                       | AISI304, AISI318 LN, or AISI431 Stainless Steel   |
| Elastomers                  | EPDM  |
| Isolation Valves            | 304 Stainless Steel Ball Valves   |
| Suction/Discharge Manifolds | AISI304 Stainless Steel with Grooved System Connections   |
| Check Valves                | Wafer Style, 316 Stainless Steel internals, Non-slam, Plunger-type with EPDM seal/ Cast Iron Body |
| Mechanical Seal             | Cartridge Seal: Sleeve AISI316L / Spring Clips AISI304  |
| Pressure Transducers        | 316 Stainless Steel   |
| Pressure Gauges             | 304 Stainless Steel Housing with 316 Stainless Steel wetted parts                                 |
| System base                 | Steel (S235JR)  |
| Vibration Isolators         | Neoprene, Height Adjustable   |

### Technical Data - Operational Ranges

|                     |  |
|---------------------|--|
| Liquid Temp Range   | -4°F to +248°F (Min. 32 °F for Domestic Water) |
| Ambient Temp Range  | +32°F to +104 °F                               |
| Max Inlet Pressure  | 145 PSI  |
| Max System Pressure | 232 PSI  |

### Technical Data - Panel

|              |                                     |
|--------------|-------------------------------------|
| Power Supply | 460-3                               |
| Enclosure    | NEMA 12 (3R Available Upon Request) |
| Standard     | Meets UL 508A                       |

### Technical Data - PLC

|                           |  |
|---------------------------|--|
| User Interface            | 7" Diagonal Color LCD Touchscreen                                    |
| Display Resolution        | 800 x 480 Pixels   |
| Supply Voltage            | 24VDC  |
| Max. Current Consumption  | 320mA@24V  |
| Number of Analog Inputs   | 9  |
| Number of Analog Outputs  | 2  |
| Number of Digital Inputs  | 18   |
| Number of Digital Outputs | 17   |
| Onboard Communications    | Modbus Protocol (Optional Gateways for BacNET, LonWorks, and CANbus) |
| Ethernet Port             | RJ45 port capable of transmitting data 10/100Mbps                    |
| Additional Ports          | 2.0 USB Port; Micro-SD Port  |

### Motor Data

|                        |  |
|------------------------|--|
| Power Supply           | 460V-3   |
| Motor Enclosure        | Totally Enclosed Fan Cooled (TEFC)   |
| Motor Efficiency       | IEC Premium Efficiency (IE5) - Electronically Commutated Motor (EC Motor with Powerhead control) |
| Enclosure Construction | Cast Iron  |
| Motor Protection Index | IP55   |
| Insulation Class       | F  |

Approval Stamp

# Submittal Data Sheet

Wilo-SIBOOSTER EXCEL - NSF 61/372 Pressure Boosting System



## SIBOOSTER-4 EXCEL V270-02-1/10.1/VCE

460 V~3

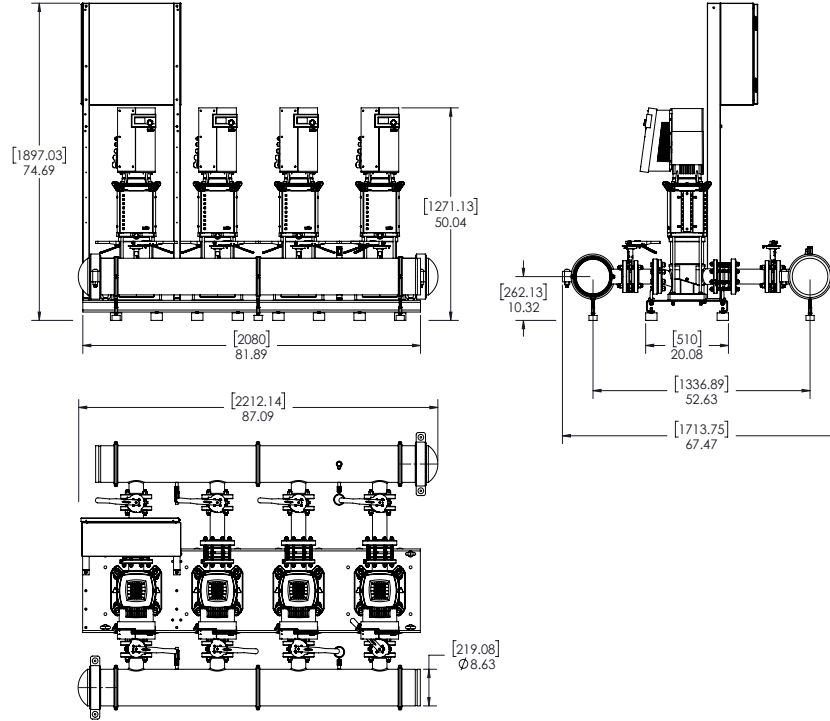

Special Note: All weights and dimensions are approximate and should not be used as exact rough-in dimensions

### Dimensions and Weights

| Model                                | Voltage (V) | Dimensions-inches |        |         |                    |  |                |                     | Individual Pump Weight                        | Package Weight    |                      |
|--------------------------------------|-------------|-------------------|--------|---------|--------------------|--|----------------|---------------------|---|-------------------|----------------------|
|                                      |             | H (in)            | W (in) | L (in)  | System Header Size | Suction / Discharge Pump Size (300 Class ANSI) | Gauge Tap Size | Transducer Tap Size | Hydronumatic Tank Valve on Manifold (Plugged) | Pump Weight (lbs) | Package Weight (lbs) |
| SIBOOSTER-4 EXCEL V270-02-1/10.1/VCE | 460 V       | 74-11/16          | 87     | 67-7/16 | 8" GROOVED         | 3"   | 1/4" FNPT      | 1/4" FNPT           | 3/4" MNPT x 3/4" FNPT                         | 282               | 1,641                |

### EC Motor Data (Single Motor Operation)

| Model                                | P2 (HP) | Phase (-) | Voltage (V) | FLA (per pump) (A) | Efficiency ηm 100% | Pmax (PSI) |
|--------------------------------------|---------|-----------|-------------|--------------------|--------------------|------------|
| SIBOOSTER-4 EXCEL V270-02-1/10.1/VCE | 10.1    | 3         | 460 (±10%)  | 10.9               | 96.4               | 232        |