

Submittal Data Sheet

Wilo-SIBOOSTER EXCEL - NSF 61/372 Pressure Boosting System



SIBOOSTER-4 EXCEL V270-01-1/5.7/VCE



| | |
|---------------|-------|
| Project: | |
| Engineer: | |
| Contractor: | |
| Submitted By: | Date: |
| Approved By: | Date: |

| Tag # | Model # | Flow | BOOST PSI | Min. Inlet PSI | HP/Pump | Phase | Voltage | RPM |
|-------|-------------------------------------|------|-----------|----------------|---------|-------|---------|------|
| | SIBOOSTER-4 EXCEL V270-01-1/5.7/VCE | | | | 5.7 | | | 3600 |

Article Number: 2701075

SIBOOST 4 EXCEL 270-01

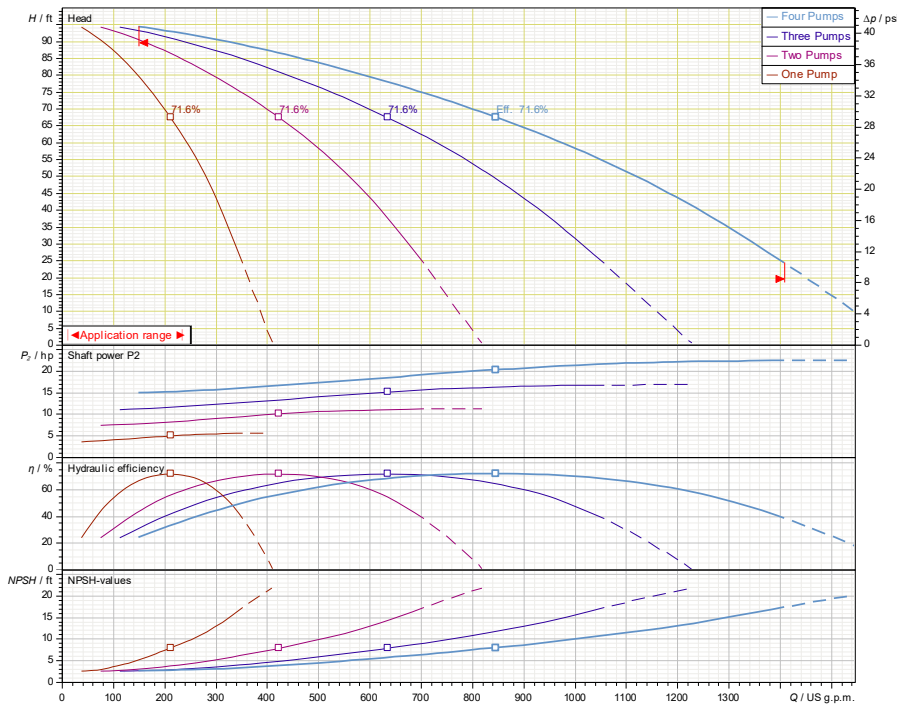

Applications

- Water Supply
- Pressure Boosting
- Agriculture
- Cooling Circuits
- Washing / Sprinkling Systems
- Condensate Return

Materials of Construction

| | |
|-----------------------------|---------------------------------------------------------------------------------------------------|
| Pump Volute | AISI304 stainless steel with ANSI flanges |
| Impeller | 3D Laser welded AISI 304 Stainless Steel |
| Shaft | AISI304, AISI318 LN, or AISI431 Stainless Steel |
| Elastomers | EPDM |
| Isolation Valves | 304 Stainless Steel Ball Valves |
| Suction/Discharge Manifolds | AISI304 Stainless Steel with Grooved System Connections |
| Check Valves | Wafer Style, 316 Stainless Steel internals, Non-slam, Plunger-type with EPDM seal/ Cast Iron Body |
| Mechanical Seal | Cartridge Seal: Sleeve AISI316L / Spring Clips AISI304 |
| Pressure Transducers | 316 Stainless Steel |
| Pressure Gauges | 304 Stainless Steel Housing with 316 Stainless Steel wetted parts |
| System base | Steel (S235JR) |
| Vibration Isolators | Neoprene, Height Adjustable |

Technical Data - Operational Ranges

| | |
|---------------------|------------------------------------------------|
| Liquid Temp Range | -4°F to +248°F (Min. 32 °F for Domestic Water) |
| Ambient Temp Range | +32°F to +104 °F |
| Max Inlet Pressure | 145 PSI |
| Max System Pressure | 232 PSI |

Technical Data - Panel

| | |
|--------------|-------------------------------------|
| Power Supply | 460-3 |
| Enclosure | NEMA 12 (3R Available Upon Request) |
| Standard | Meets UL 508A |

Technical Data - PLC

| | |
|---------------------------|----------------------------------------------------------------------|
| User Interface | 7" Diagonal Color LCD Touchscreen |
| Display Resolution | 800 x 480 Pixels |
| Supply Voltage | 24VDC |
| Max. Current Consumption | 320mA@24V |
| Number of Analog Inputs | 9 |
| Number of Analog Outputs | 2 |
| Number of Digital Inputs | 18 |
| Number of Digital Outputs | 17 |
| Onboard Communications | Modbus Protocol (Optional Gateways for BacNET, LonWorks, and CANbus) |
| Ethernet Port | RJ45 port capable of transmitting data 10/100Mbps |
| Additional Ports | 2.0 USB Port; Micro-SD Port |

Motor Data

| | |
|------------------------|--------------------------------------------------------------------------------------------------|
| Power Supply | 460V-3 |
| Motor Enclosure | Totally Enclosed Fan Cooled (TEFC) |
| Motor Efficiency | IEC Premium Efficiency (IE5) - Electronically Commutated Motor (EC Motor with Powerhead control) |
| Enclosure Construction | Cast Iron |
| Motor Protection Index | IP55 |
| Insulation Class | F |

Approval Stamp

Submittal Data Sheet

Wilo-SIBOOSTER EXCEL - NSF 61/372 Pressure Boosting System



SIBOOSTER-4 EXCEL V270-01-1/5.7/VCE

460 V~3

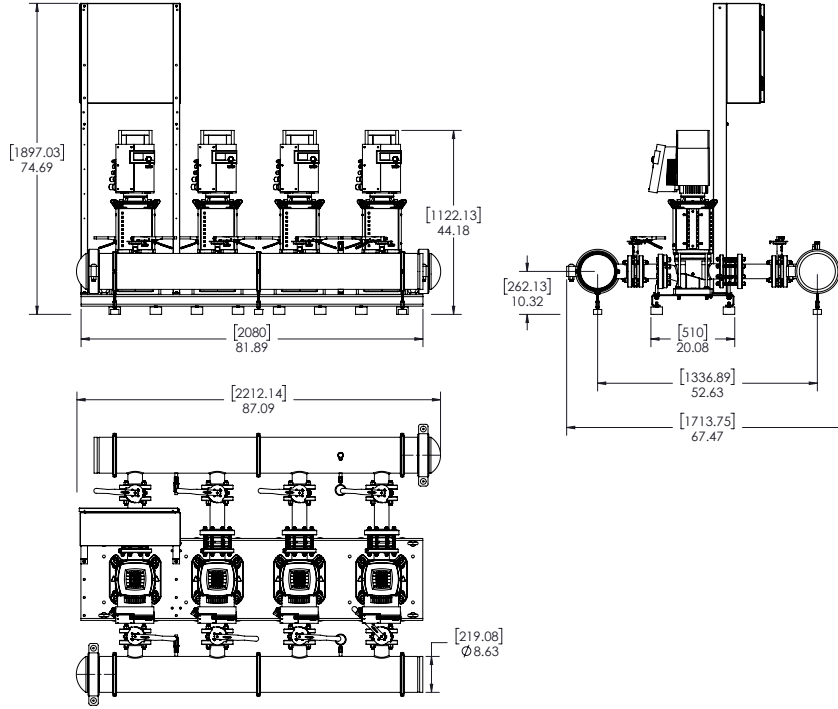

Special Note: All weights and dimensions are approximate and should not be used as exact rough-in dimensions

Dimensions and Weights

| Model | Voltage (V) | Dimensions-inches | | | | | | | Individual Pump Weight | | Package Weight |
|-------------------------------------|-------------|-------------------|--------|---------|--------------------|------------------------------------------------|----------------|---------------------|-----------------------------------------------|-------------------|----------------------|
| | | H (in) | W (in) | L (in) | System Header Size | Suction / Discharge Pump Size (300 Class ANSI) | Gauge Tap Size | Transducer Tap Size | Hydronumatic Tank Valve on Manifold (Plugged) | Pump Weight (lbs) | Package Weight (lbs) |
| SIBOOSTER-4 EXCEL V270-01-1/5.7/VCE | 460 V | 74-11/16 | 87 | 67-7/16 | 8" GROOVED | 3" | 1/4" FNPT | 1/4" FNPT | 3/4" MNPT x 3/4" FNPT | 227 | 1,586 |

EC Motor Data (Single Motor Operation)

| Model | P2 (HP) | Phase (-) | Voltage (V) | FLA (per pump) (A) | Efficiency ηm 100% | Pmax (PSI) |
|-------------------------------------|---------|-----------|-------------|--------------------|--------------------|------------|
| SIBOOSTER-4 EXCEL V270-01-1/5.7/VCE | 5.7 | 3 | 460 (±10%) | 6.5 | 95.8 | 232 |