

Submittal Data Sheet

Wilo Stratos Z - High Efficiency Circulators



Stratos Z 1.5x3-25

	Project:						
	Engineer:						
	Contractor:						
	Submitted By:				Date:		
	Approved By:				Date:		
Tag #	Model #	Flow	Head	Control Mode	Cycle	Phase	Voltage
	Stratos Z 1.5x3-25				60Hz	1	230

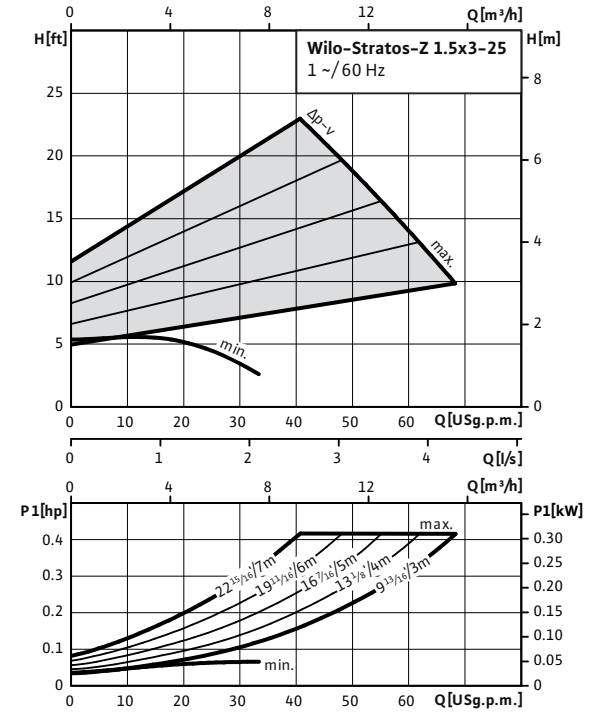
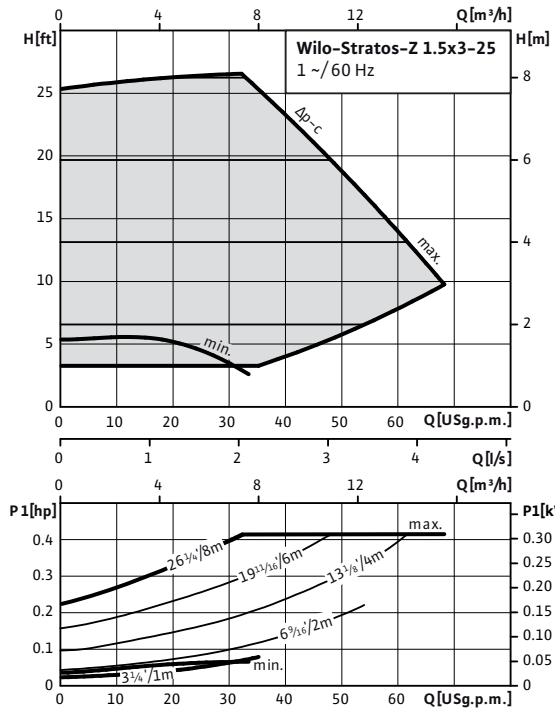

Technical Data	
Liquid Temp Range	14°F to 230°F (-10°C to 110°C)
Max Temperature	104°F (40°C)
Min. Suction Pressure (122°F)	10.0 PSI
Min. Suction Pressure (203°F)	21.3 PSI
Min. Suction Pressure (230°F)	32.7 PSI

Materials of Construction	
Pump Volute	Stainless steel
Impeller	Composite (PPS-40% GF)
Shaft	Stainless Steel (X39CrMo17-1)
Bearing	Carbon, synthetic resin impregnated

IR Module Selection	
Module 1	Module
	BACnet / Dual Pump
	LONworks / Dual Pump
	SBM Run Signal / Ext. Off / Dual Pump
	SBM Run Signal / 0-10v / Dual Pump
	Ext. Min / 0-10v / Dual Pump
	Ext. Off / 0-10v / Dual Pump
	None

Applications	
• Heating Systems	• Cooling Circuits
• Air Conditioning	• Industrial Circulation
• Solar Systems	• Geothermal Systems

Approval Stamp

Submittal Data Sheet

Wilo Stratos Z - High Efficiency Circulators



Dimensions & Weights

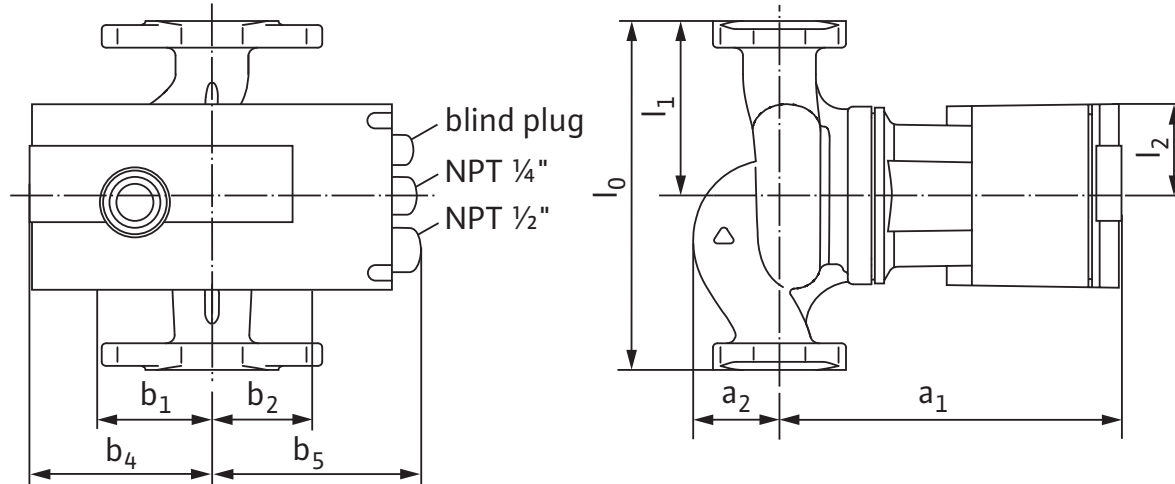

Dimensions and Weights

Model	Dimensions - Inches (mm)									Weight - lbs (kg)
	l_0	l_1	l_2	a_1	a_2	b_1	b_2	b_4	b_5	
Stratos Z 1.5x3-25	8½	4¼	2 ^{3/16}	8	2 ^{1/16}	2 ^{5/8}	2 ^{3/16}	4 ^{3/16}	5¾	20.94
	(216)	(108)	(55)	(203)	(53)	(66)	(55)	(106)	(146)	(9.5)

Flange Dimensions

Dimensions - Inches (mm)				
Dia.	ϕD	ϕd	ϕk	$n \times d_L$
1½"	4¾	2 ^{7/8}	3½	2 x ^{9/16}
	(121)	(73)	(89)	(2 x 14)

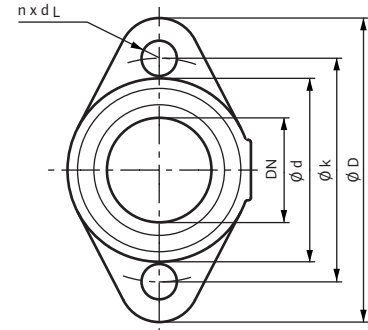

ECM Motor Data

Model	hp	Speed	Watts	FLA	FLA
		RPM	W	1~230V	3~230V
Stratos Z 1.5x3-25	0.268	1800-4800	18-310	0.17-1.37	0.17-1.37

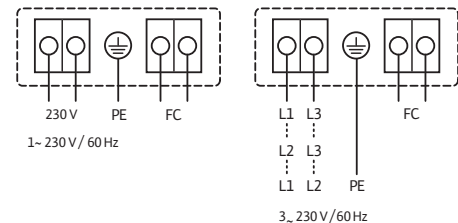

WILO USA LLC

Tel: (888) 945-6872 Web: www.wilo-usa.com
 Fax: (888) 945-6873 Email: info@wilo-usa.com

WILO Canada Inc.

Tel: (866) 945-6236 Web: www.wilo-canada.com
 Fax: (403) 277-9456 Email: info@wilo-canada.com

WILO Mexico

Tel: +52 55 5586 3209 Web: www.wilo-mexico.com.mx
 Fax: +52 1 55 5413 4165 Email: info@wilo.com.mx