

Submittal Data Sheet

Wilco MVI - Vertical Multistage Pumps



Wilco MVI 30



Project:	
Engineer:	
Contractor:	
Submitted By:	Date:
Approved By:	Date:

Tag #	Model #	Flow	Head	HP	Cycle	Phase	Voltage	RPM
					60Hz	1		3500

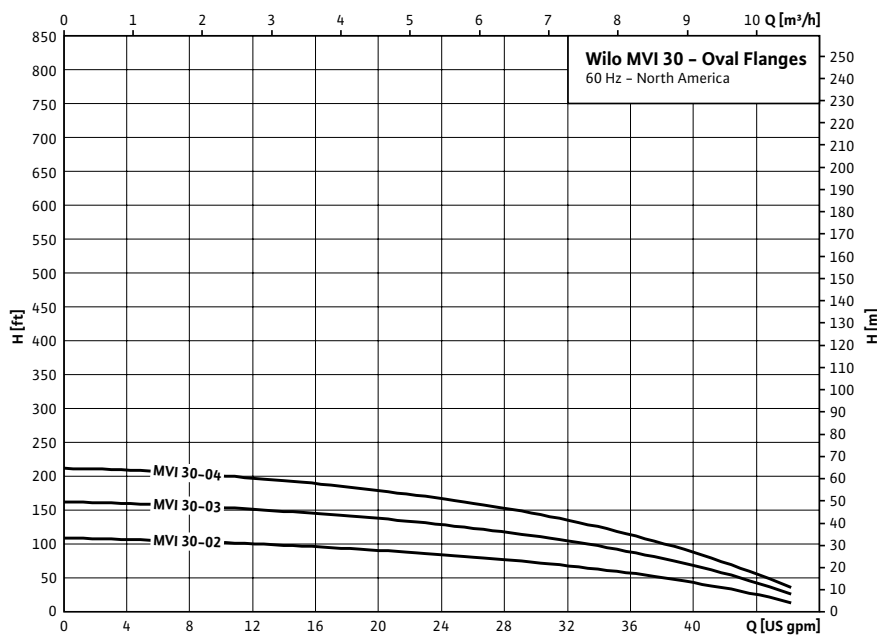

Technical Data	
Liquid Temp Range	5°F to 250°F (-15°C to 121°C)
Power Supply	1 - 115/230v
Ambient temperature limits	Maximum 104°F - <90% humidity (motor-dependent)
Flange Connection	1 1/4" FNPT Oval Flanges Included
Max suction pressure	140 PSI
Motor Options	TEFC Standard

Materials of Construction	
Pump volute	Stainless steel
Impeller	Stainless steel AISI 304 (1.4301)
Shaft	Stainless steel AISI 304 (1.4301)
Mechanical seal	Carbon/tungsten carbide, SiC/carbon, EPDM elastomers

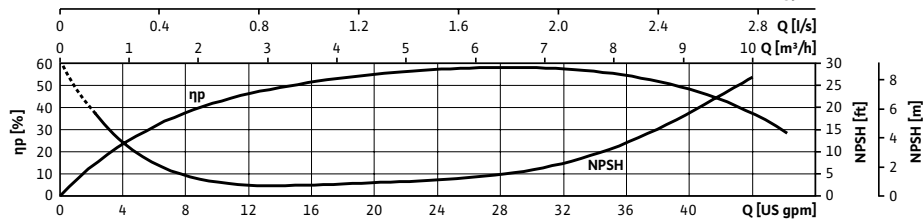

Applications	
• Water supply & pressure boosting	• Washing and sprinkling systems
• Condensate return	• Process engineering
• Boiler feed	• Cooling-water circuits
• Geothermal	• Heating

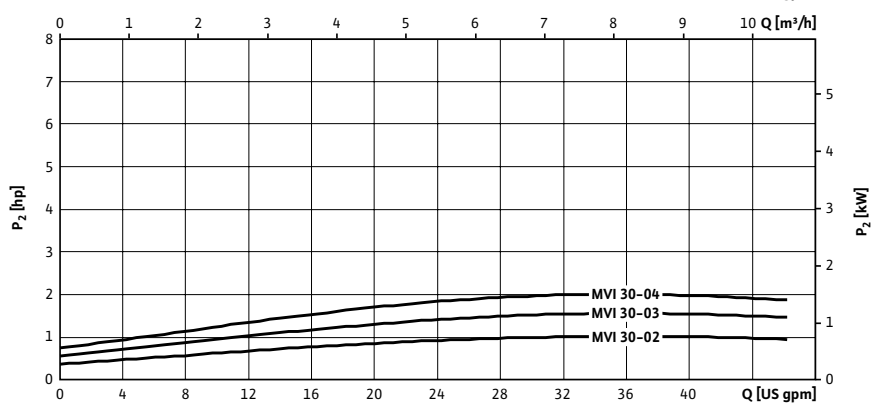

Approval Stamp

Submittal Data Sheet

Wilco MVI - Vertical Multistage Pumps



Dimensions & Weights

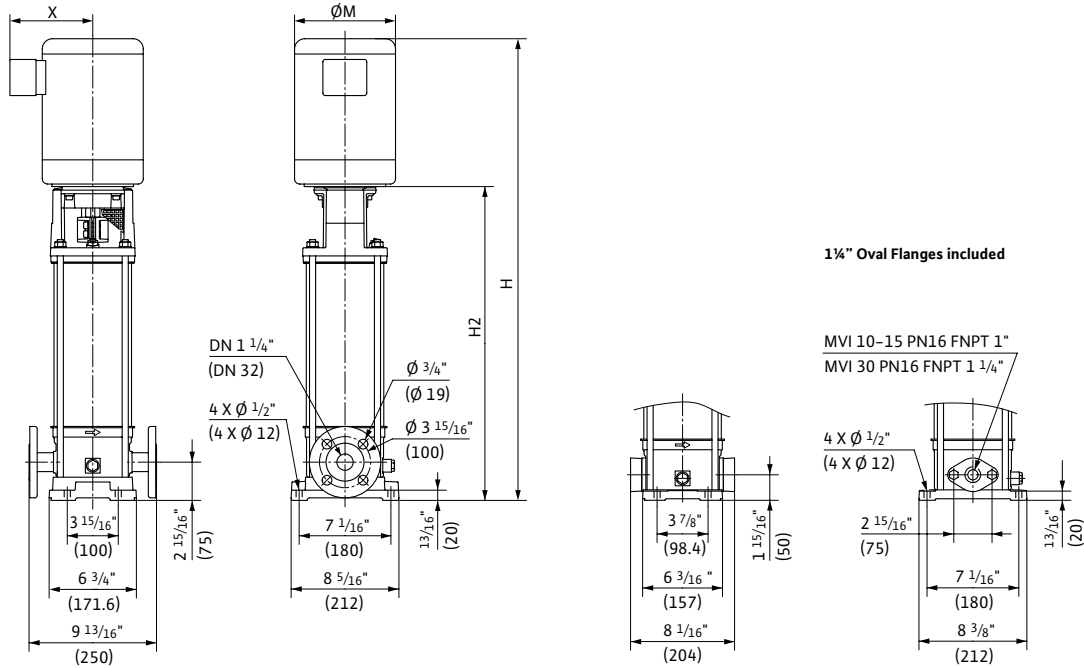

Dimensions and Weights

TEFC Motor Data

Model	Dimensions-inches (mm)								Weight	
	H		H ₂		M		X		lbs	kg
	in	(mm)	in	(mm)	in	(mm)	in	(mm)		
MVI 30-02	25 ^{11/16}	(652)	13 ^{3/16}	(336)	7 ^{3/16}	(183)	5 ^{3/4}	(146)	67.3	30.5
MVI 30-03	26 ^{1/16}	(662)	13 ^{5/8}	(346)	7 ^{3/16}	(183)	5 ^{3/4}	(146)	67.6	30.7
MVI 30-04	27	(686)	14 ^{9/16}	(370)	7 ^{3/16}	(183)	5 ^{3/4}	(146)	81	36.7

P2	Phase	Voltage	FLA
[HP]	[-]	[V]	[A]
1	1	115/230	11.8/5.9
1.5	1	115/230	16.0/8.0
2	1	115/230	23.0/11.5