

# Submittal Data Sheet

## Wilco MVI - Vertical Multistage Pumps



### Wilco MVI 10



Project:	
Engineer:	
Contractor:	
Submitted By:	Date:
Approved By:	Date:

Tag #	Model #	Flow	Head	HP	Cycle	Phase	Voltage	RPM
					60Hz	1		3500

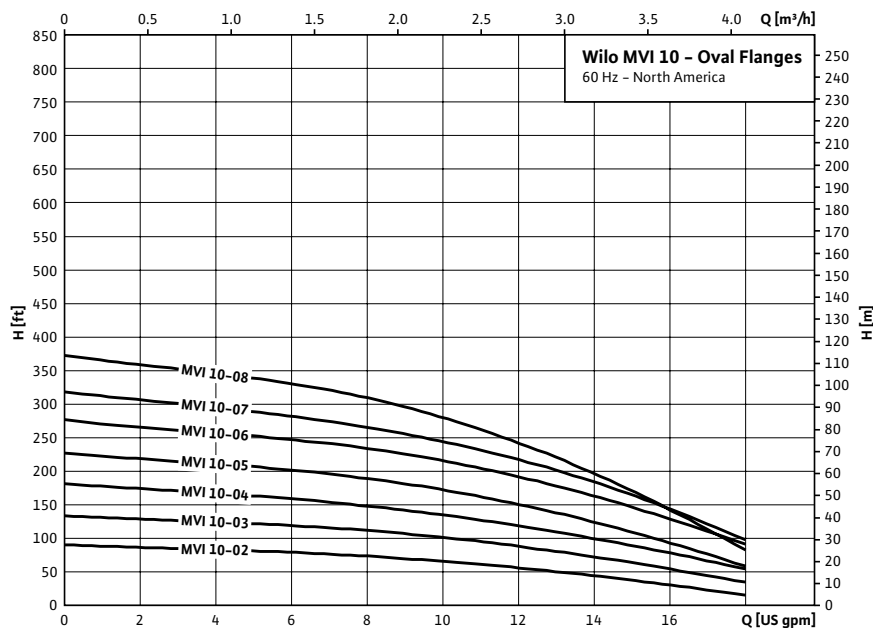

Technical Data	
Liquid Temp Range	5°F to 250°F (-15°C to 121°C)
Power Supply	1 ~ 115/230v
Ambient temperature limits	Maximum 104°F - <90% humidity (motor-dependent)
Flange Connection	1" FNPT Oval Flanges <b>Included</b>
Max suction pressure	140 PSI
Motor Options	TEFC Standard

Materials of Construction	
Pump volute	Stainless steel
Impeller	Stainless steel AISI 304 (1.4301)
Shaft	Stainless steel AISI 304 (1.4301)
Mechanical seal	Carbon/tungsten carbide, SiC/carbon, EPDM elastomers

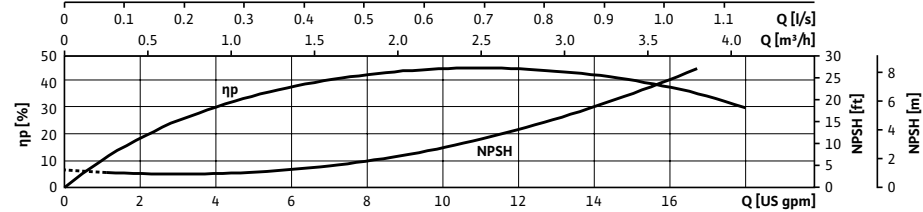

Applications	
• Water supply & pressure boosting	• Washing and sprinkling systems
• Condensate return	• Process engineering
• Boiler feed	• Cooling-water circuits
• Geothermal	• Heating

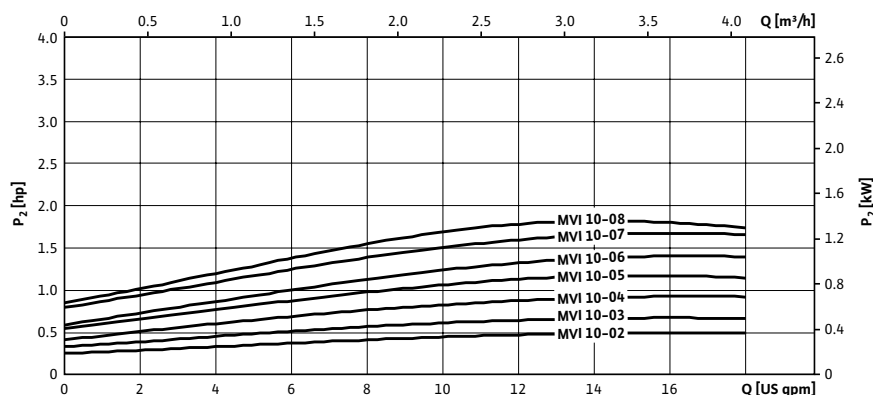

Approval Stamp

# Submittal Data Sheet

Wilo MVI - Vertical Multistage Pumps



## Dimensions & Weights

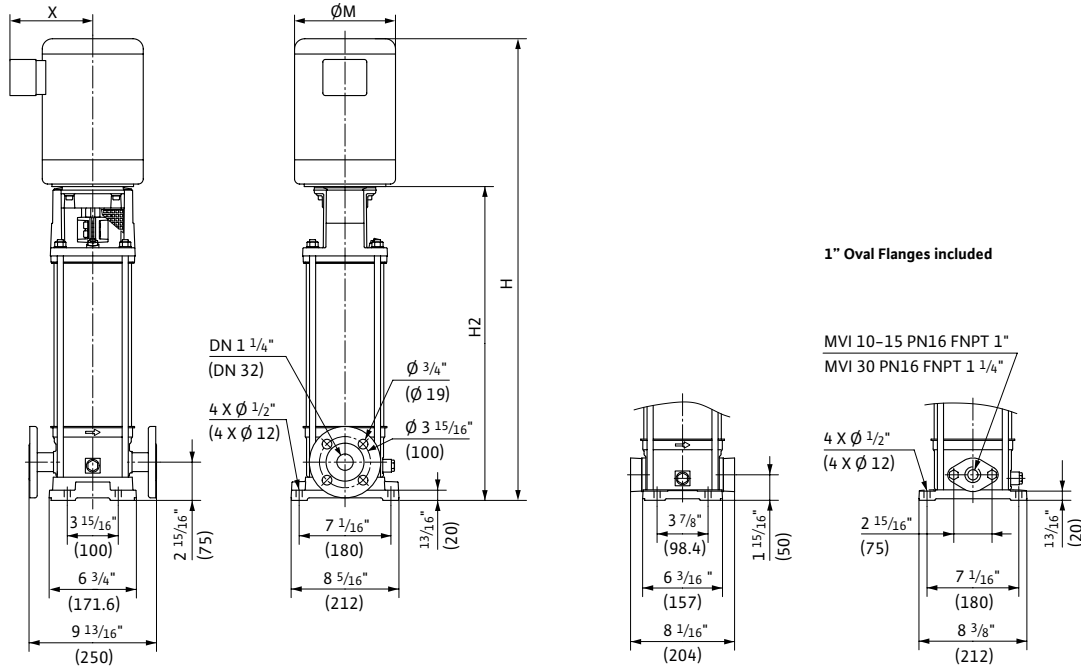

### Dimensions and Weights

Model	Dimensions—inches (mm)								Weight	
	H		H <sub>2</sub>		M		X		lbs	kg
	in	(mm)	in	(mm)	in	(mm)	in	(mm)		
MVI 10-02	24 1/4	(616)	13 15/16	(354)	6 3/16	(157)	5 3/16	(132)	61	27.7
MVI 10-03	24 1/4	(616)	13 15/16	(354)	6 3/16	(157)	5 3/16	(132)	61.2	27.8
MVI 10-04	26 3/8	(670)	13 15/16	(354)	7 3/16	(183)	5 3/4	(146)	69.5	31.5
MVI 10-04	28	(710)	14 3/4	(374)	7 3/16	(183)	5 3/4	(146)	74.8	33.9
MVI 10-05	28	(710)	15 1/2	(394)	7 3/16	(183)	5 3/4	(146)	75.3	34.2
MVI 10-06	28 3/4	(730)	15 5/16	(414)	7 3/16	(183)	5 3/4	(146)	90.7	41.1
MVI 10-08	30 5/16	(770)	17 7/8	(454)	7 3/16	(183)	5 3/4	(146)	93.3	42.3

### TEFC Motor Data

P2	Phase	Voltage	FLA
1/2	1	115/230	7.0/3.5
3/4	1	115/230	9.4/4.7
1	1	115/230	11.8/5.9
1.5	1	115/230	16.0/8.0
1.5	1	115/230	16.0/8.0
2	1	115/230	23.0/11.5
2	1	115/230	23.0/11.5