

Submittal Data Sheet

Wilco Top S - Commercial Wet Rotor Circulators



Top S - Three Phase



Project:	
Engineer:	
Contractor:	
Submitted By:	Date:
Approved By:	Date:

Tag #	Model #	Speed	Flow	Head	HP	Phase	Voltage
	Top S 1.5 x 40					3	

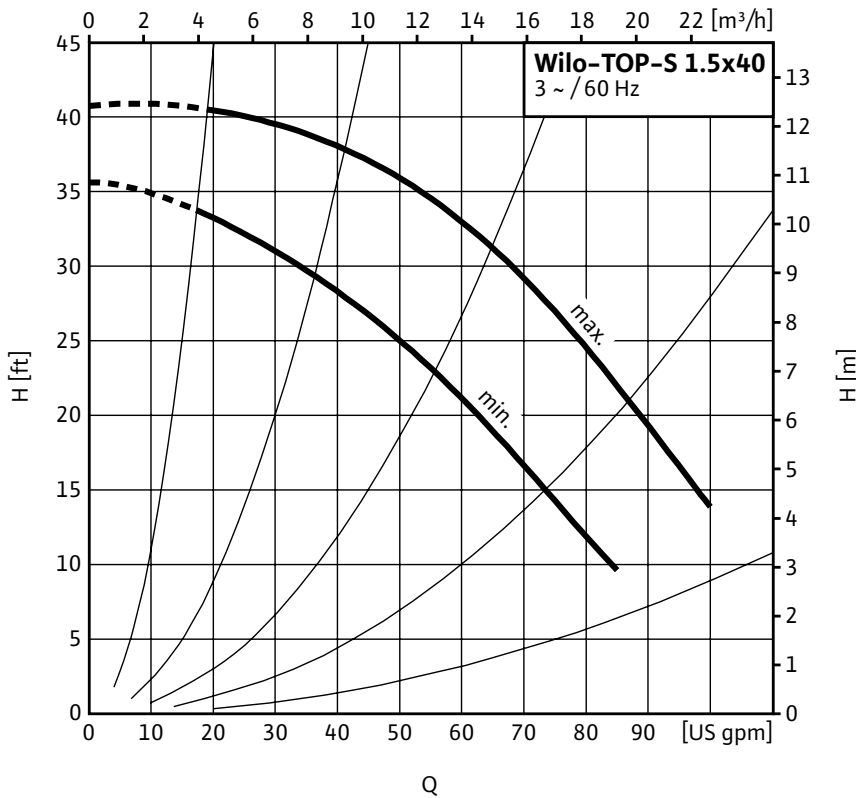

Materials of Construction	
Volute	Cast Iron (Closed Systems) Cataphoresis Coated
Impeller	Engineered composite (PP - 50% GF)
Shaft	Stainless Steel (X40 Cr13) / AISI 420SS
Bearing	Metal Impregnated Carbon
Degree of Protection	Enclosure
Protection Class	H

Technical Data	
Max. Temp. Range	14°F 248°F (- 10°C to 120°C)
Ambient Temp. Range	32°F - 104°F (0°C - 40 °C)
Electrical Connections	3~208-230v, 460v, 575v
Max. Working Pressure	145 PSI (10 Bar)
Min. Inlet Pressure 140 °F (60 °C)	1.8 PSI (0.1 Bar)
Min. Inlet Pressure 194 °F (90 °C)	7.3 PSI (0.5 Bar)
Min. Inlet Pressure 248 °F (120 °C)	29.9 PSI (2 Bar)

Applications	
• Heating Systems	• Cold water and air-conditioning systems
• Geothermal Systems	• Water/Glycol up to 50%
• Solar Systems	• Industrial Circulation Systems

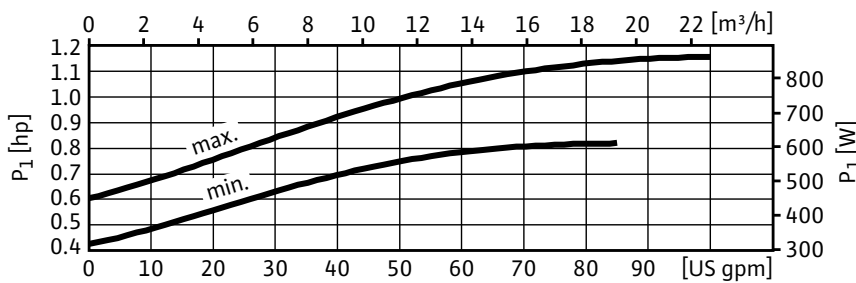

Approval Stamp

Submittal Data Sheet

Wilo Top S – Commercial Wet Rotor Circulators



Dimensions & Weights

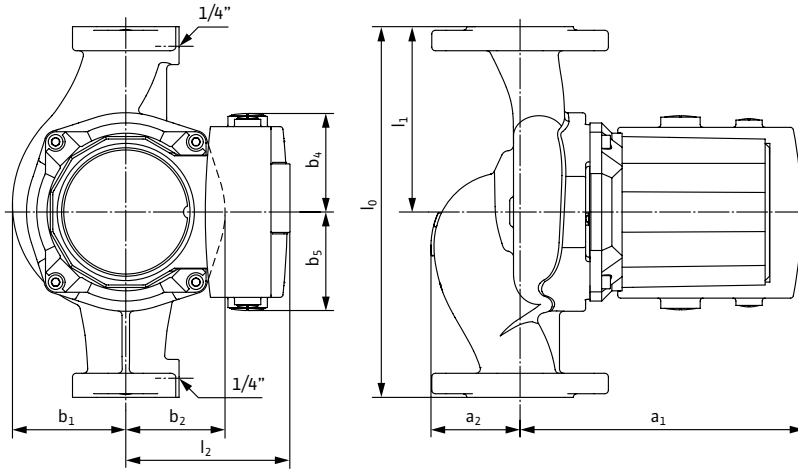

Dimensions and Weights

Model	Dimensions - Inches (mm)									Weight - lbs (kg)
	l_0	l_1	l_2	a_1	a_2	b_1	b_2	b_4	b_5	
Top S 1.5 x 40	10	5	4¾	9¼	2 ⁵ / ₁₆	3 ⁹ / ₁₆	3 ¹ / ₈	2¾	2¾	28.7
	(254)	(127)	(120)	(235)	(58)	(90)	(79)	(70)	(70)	(13)

Flange Dimensions

Dia. (DN)	Dimensions - Inches (mm)				
	ϕD	ϕd_1	ϕd_2	ϕk	$n \times d_L$
1½"	4¾	1 ⁵ / ₈	2 ⁷ / ₈	3½	2 x ϕ ½
	(121)	(41)	(73)	(89)	(2 x ϕ 14)

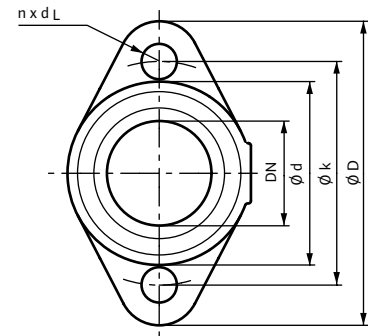

Motor Data

Model	hp	Speed RPM	Watts W	FLA		
				3~208-230V	3~460V	3~575V
Top S 1.5 x 40	5/8	2890-3330	615-870	1.9-3.0	0.9-1.5	0.7-1.2