

Submittal Data Sheet

Wilco NL - Base Mounted End Suction Pumps

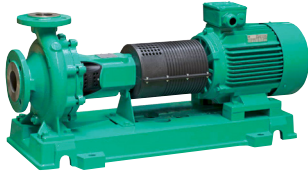

NL 2½ x 2 x 5



Project:	
Engineer:	
Contractor:	
Submitted By:	Date:
Approved By:	Date:

Tag #	Model #	Flow (USGPM)	Head (Feet)	HP	Enclosure TEFC/ODP	Frame	Cycle	Phase	Voltage	RPM
	NL 2½ x 2 x 5						60Hz	3		1750

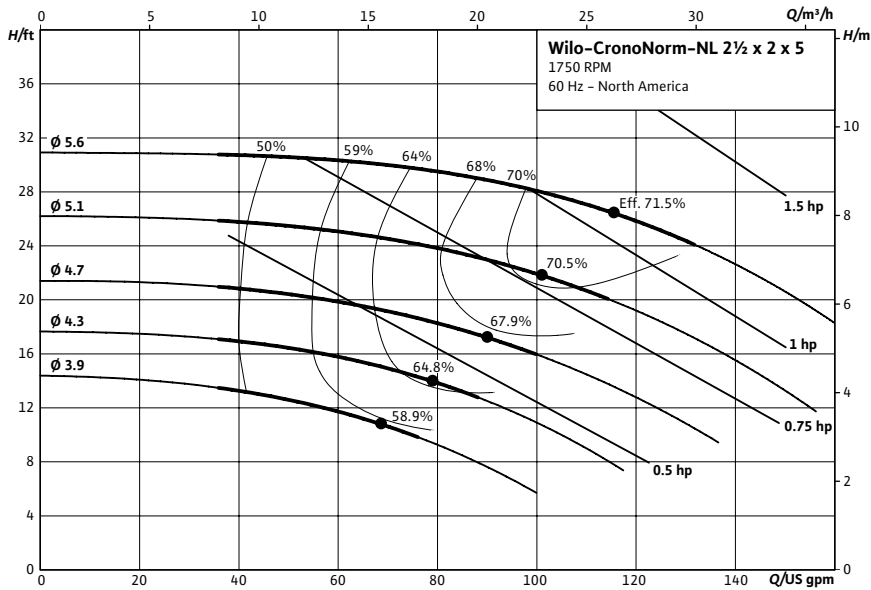

Technical Data

Approved Fluids
 Heating Water
 Cooling and cold water
 Water-Glycol mixtures (for 20-40% glycol and fluid temp ≤ 104°F (40°C))

Fluid Temperature
 Mechanical Seal: 18°F to 250°F (-8°C to 120°C)
 Stuffing Box Packing: 32°F to 220°F (0°C to 105°C)

Materials of Construction

<input type="checkbox"/> Pump Housing	C.I. FG260
<input type="checkbox"/> Impeller	Bronze LG2
<input type="checkbox"/> Impeller (optional)	C.I. FG260
<input type="checkbox"/> Pump Shaft	SS AISI 420
<input type="checkbox"/> Mechanical Seal	Carbon/silicon carbide/EPDM (E1)
<input type="checkbox"/> Other Mechanical Seals	Avail. on request
<input type="checkbox"/> Additional Spacer Coupling	Avail. on request
<input type="checkbox"/> Other:	

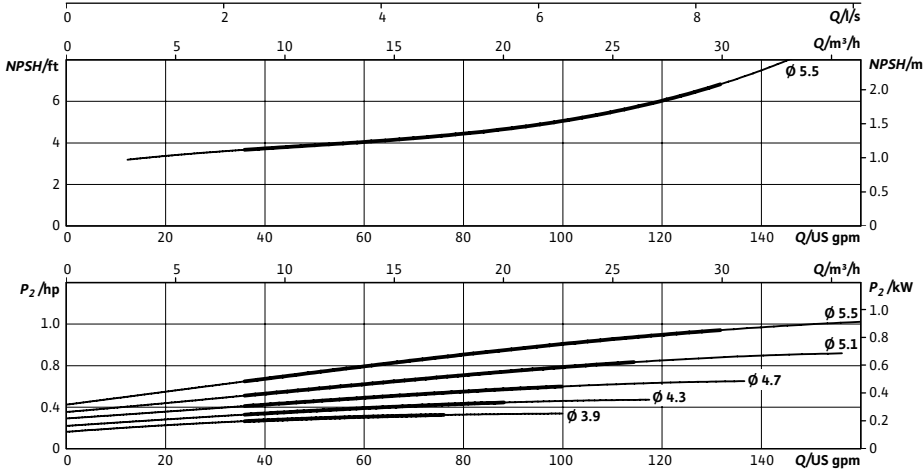

Approval Stamp

Submittal Data Sheet

Wilo NL – Base Mounted End Suction Pumps



Dimensions & Weights

Wilo NL

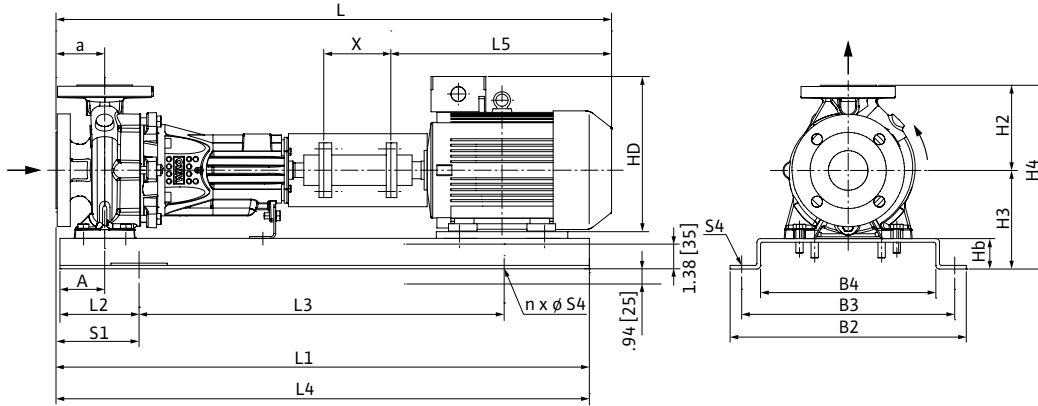

NL 2½x 2 x 5

Dimensions – Inches (mm)

Frame	a	A	L	L1	L2	L3	L4	L5	X	HD	H2	H3	H4	Hb	B2	B3	B4	n	S1	S4
56	3.94 (100)	2.63 (67)	34.06 (865)	32.88 (835)	5.94 (151)	21.00 (533)	34.19 (868)	15.50 (394)	.5 (13)	6.81 (173)	6.31 (160)	7.56 (192)	13.88 (353)	2.38 (60)	14.88 (378)	13.19 (335)	10.94 (278)	4	7.25 (184)	.88 (22)
143T	3.94 (100)	2.63 (67)	34.19 (868)	32.88 (835)	5.94 (151)	21.00 (533)	34.19 (868)	15.56 (395)	.5 (13)	6.81 (173)	6.31 (160)	7.56 (192)	13.88 (353)	2.38 (60)	14.88 (378)	13.19 (335)	10.94 (278)	4	7.25 (184)	.88 (22)
145T	3.94 (100)	2.63 (67)	34.19 (868)	32.88 (835)	5.94 (151)	21.00 (533)	34.19 (868)	15.56 (395)	.5 (13)	6.81 (173)	6.31 (160)	7.56 (192)	13.88 (353)	2.38 (60)	14.88 (378)	13.19 (335)	10.94 (278)	4	7.25 (184)	.88 (22)

Flange Dimensions – Suction Side

Dimensions – Inches (mm)

DN S #125	ØD	Ød	Øk	b	n	D2
2½	7.00 (178)	4.13 (105)	5.50 (140)	.88 (22)	4	.75 (19)

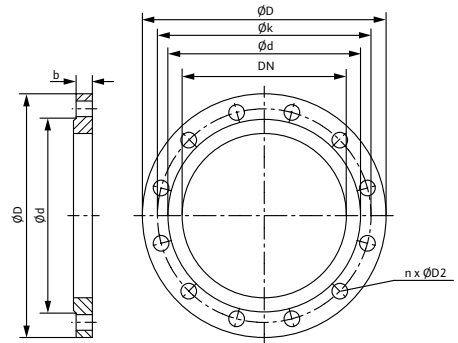

Flange Dimensions – Discharge Side

Dimensions – Inches (mm)

DN D 125#	ØD	Ød	Øk	b	n	D2
2	6.00 (152)	3.63 (92)	4.75 (121)	.75 (19)	4	.75 (19)