

Highlight Catalogue Water Management 2016/2017

Drainage and Sewage

Pumps and Pump Systems



GOING #BEYOND PUMPS

The Wilo way: Tailored solutions with personal dedication.

Wilo water management: This is more than innovative technology and many years of expertise. For us the Wilo way is to provide you with any information whenever and wherever required to make your project succeed. From the design stage, through documentation, to personal support on-site. That is how we live our brand promise "Pioneering for You".

How can Wilo support you? www.wilo.com/WaterManagement



Wilo-TRE 312



Wilo-Rexabloc RE



Wilo-Port 600



Wilo-EMU FA



Drainage and Sewage		
Dewatering and Flood control		page
	Wilo-EMU KS	6
	Wilo-Drain TS/TSW 32	7
Wastewater collection and transport		
	Wilo-Rexa CUT	8
	Wilo-Rexa PRO	9
	Wilo-EMU FA (DN 80... DN 600)	10
	Wilo-Port 600/800	11
	Wilo-EMUport CORE	12
	Wilo-RexaBloc RE	13
	Wilo-RexaNorm RE	14
Submersible mixer		
	Wilo-EMU TR 14... – TR 28...	15
	Wilo-EMU TR 22... – TR 40...	16
	Wilo-EMU TR 50-2... – TR 120-1...	17
	Wilo-EMU TR 212... – TR(E) 326...	18
Recirculation pumps		
	Wilo-EMU RZP	19
Axial submersible pumps		
	Wilo-EMU KPR	20

Wilo

Pioneering for You.



We are there for you worldwide.

Since 1872, we at Wilo have been turning visionary ideas into intelligent solutions that regularly set new standards in the industry. The goal of our company founder, Caspar Ludwig Opländer, was to use his copper and brass goods factory to improve and facilitate the supply of water to people. It did not take long for the company to take the key step: in 1928, his son Wilhelm designed the world's first circulation accelerator.

We have been continuing this tradition ever since with pioneering innovations in the heating, air-conditioning and cooling sector, such as the world's first high-efficiency pump, and at the same time we have proven our commitment to using valuable resources such as energy and water responsibly. Today the Wilo Group, headquartered in Dortmund, is represented across the globe as an all-round provider of pumps and pump systems for water management.

Cooperative support you can rely on.

With over 7,500 employees and 60 production and sales companies all over the world, we personally see to it that our customers' and users' needs and requirements – whether they are specialist consultants, operators, or general contractors – are met optimally every day. This means making your life and work as easy as possible with our products, solutions and services.

“Pioneering for You” is our permanent pledge of clear customer focus, unrelenting pursuit of quality, and of our special passion for techno-

logy. In times of dwindling natural resources, the responsible management of water is an extremely important task, which is why we are committed to providing pioneering developments, sustainable product solutions, and cooperative support to ensure you can rely on our solutions for the daily management of water. That's what we call Pioneering for You.



**“The best solutions
are created through
top partnership,
that's what I call Pioneering for You.”**

Daniel Busuioc, International Project Coordinator of Group Competence Team,
WILO SE, Hof, Germany

Wilo-EMU KS

Submersible drainage pump

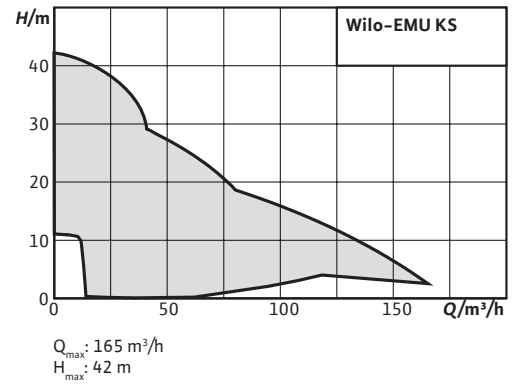

Special features/product advantages

- Long service life
- Heavy-duty design
- Slurping operation possible
- Suitable for continuous duty (S1)
- Ready-to-plug

Application

- Pumping of Waste water



Going
#beyondpumps

Wilo-Drain TS/TSW 32

Submersible drainage pump

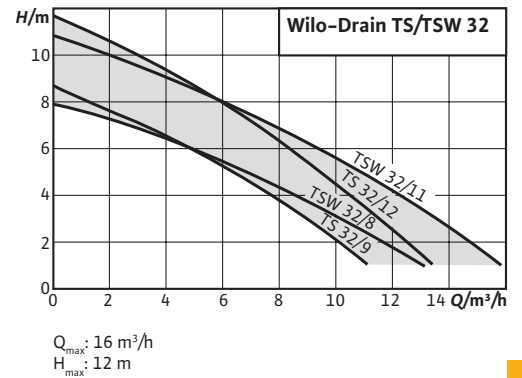

Special features/product advantages

- Sturdy, impact-resistant stainless steel housing – perfect for mobile application
- Turbulator twister (TSW): constantly clean pump chamber and no generation of fluid-related odours
- Quick installation due to Plug & Pump (pump ready for connection)
- Sheath current cooling and motor temperature monitoring
- High-quality motor seal with additional dirt deflector
- Detachable connection cable and float switch

Application

- For pumping clear or slightly muddy water
- From tanks, sumps or pits
 - For overflows and flooding
 - For draining basement stairways and basement areas
 - From domestic areas (washing machine water, soapsuds)
 - From small fountains, waterworks or streams



Going #beyondpumps

Wilo-Rexa CUT

Submersible sewage pump with macerator for intermittent duty and continuous duty, for stationary and portable wet well installation

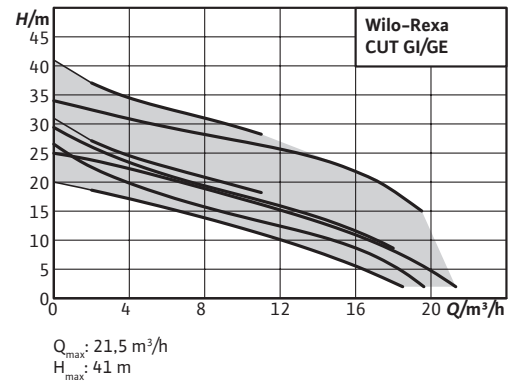

Special features/product advantages

- High reliability through ATEX approval and longitudinally watertight cable inlet (CUT GE...)
- High operational reliability through spherically-formed macerator with pulling cut
- Long service life through a high-quality motor seal with two independent mechanical seals and optional pencil electrode for sealing chamber control

Application

- Pumping of
- Sewage containing faeces
 - Pre-cleaned sewage without faeces and long-fibre components
 - Wastewater



Going
#beyondpumps

Wilo-Rexa PRO

Submersible sewage pump for continuous duty for stationary and portable wet well installation, as well as for stationary dry well installation

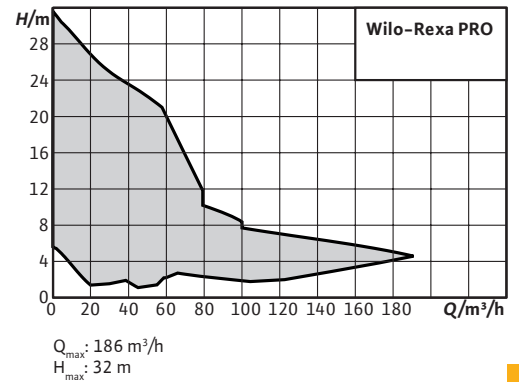

Special features/product advantages

- Extremely effective. Thanks to efficiency-optimized single-channel impellers
- Safe to operate due to low-clogging vortex impellers
- Verified safety: Ex-rated in accordance with ATEX as standard
- Energy-efficient IE3 motor technology available as an option

Application

- Pumping of
- Sewage containing faeces
 - Pre-cleaned sewage without faeces and long-fibre components
 - Wastewater

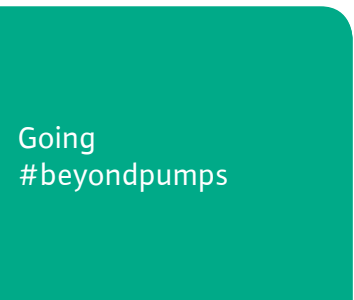

Wilo-EMU FA (DN 80... DN 600)

Submersible sewage pump with and without active cooling system for continuous duty in the stationary and portable wet well installation, as well as for stationary dry well installation

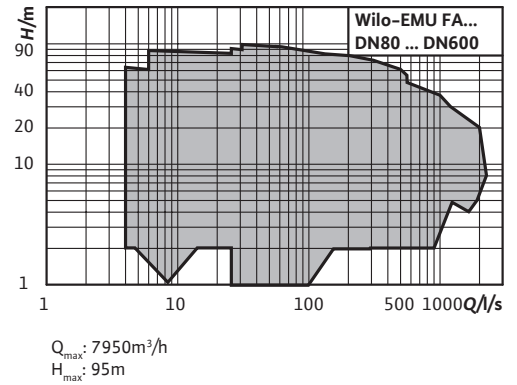
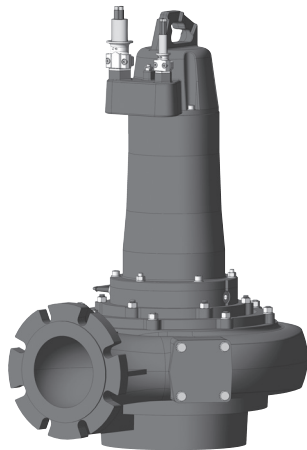

Special features/product advantages

- Can be customized exactly to your requirements. For reliable and efficient pumping of pre-cleaned sewage and untreated sewage.
- Versatile. Constant, optimal pumping of different media via various forms of impeller.
- Energy-efficient with optionally-available IE3 motor technology
- Protected against abrasion and corrosion with Ceram coating and special materials
- Suitable for immersed and non-immersed applications, also in continuous duty

Application

- Pumping of
- Untreated sewage with faeces and long-fibre components
 - Sewage containing faeces
 - Pre-cleaned sewage without faeces and long-fibre components
 - Process water
 - Wastewater

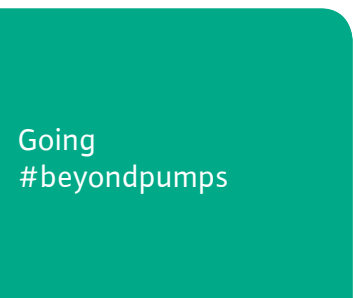

Wilo-Port 600/800

Plastic pump chamber for insertion into the ground



Special features/product advantages

- Can be driven over – even by heavy-duty vehicles – thanks to pump covers that are directly mountable on the chamber
- Flexible adaptability during the installation phase due to a variable pump chamber extension up to 2.75 m
- Maximum operational reliability and protection against leakage via the one-piece chamber body up to 2.25 m
- Long service life thanks to the use of corrosion-free materials
- Simple maintenance with easily accessible valves thanks to the surface coupling
- Easy installation thanks to the light polyethylene chamber body and integrated inlet connecting pieces
- Anti-buoyant chamber body without additional weights via circumferential chamber ribs

Application

- Single-pump chamber for underground use outside build-ings for pumping wastewater and sewage from spaces and surfaces beneath the backflow leel. Can also be used as a compact pressure drainage pump chamber with macerator pumps.

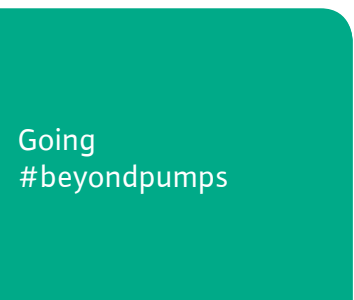

Wilo-EMUport CORE

Standard sewage lifting unit with solids separation system for installation in a building or in a pump chamber for outdoor installation

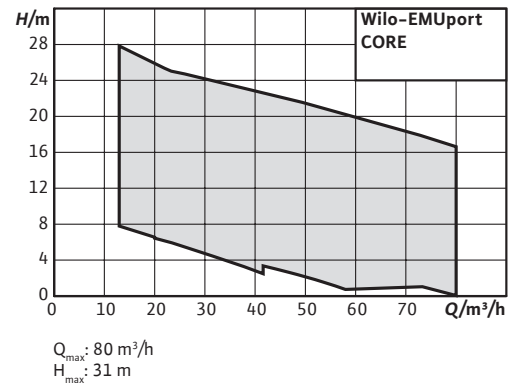

Special features/product advantages

- Maximum operational safety with separation of solids from the sewage: Large solids do not have to pass through the pump – no clogging
- Cost-effective thanks to retrofit system for simple renovation of old pumping stations
- Durable and corrosion-free due to the use of PE and PUR material
- Easy maintenance thanks to hygienic dry well installation and easy access from outside
- Future-proof even with increasing solid content in sewage
- Flexible installation in buildings or in chambers from 1,500mm diameter
- Energy savings due to efficient submersible sewage pumps with IE3 motors

Application

- Pumping of untreated sewage that cannot be returned to the sewer system using natural falls, and for the draining of objects that are below the backflow level (according to DIN EN 12056/DIN 1986-100)



Going #beyondpumps

Wilo-RexaBloc RE

Sewage pump in block design with standard motor for stationary dry well installation

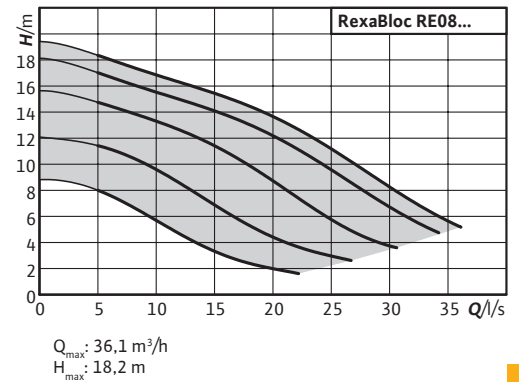
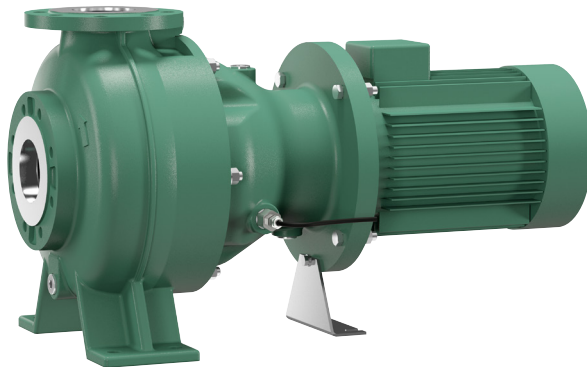

Special features/product advantages

- High operational reliability due to shut bearing bracket design with oil-filled sealing chamber and additional leakage chamber.
- Optionally with two mechanical seals for increased operational reliability.
- Equipped with IE3 motors as standard. Optionally available with IE4 premium motors.
- Simple maintenance due to „back pullout“ design. This means the motor and the impeller can be removed without needing to remove the hydraulics from the piping

Application

- Pumping of
- Sewage containing faeces
 - Pre-cleaned sewage without faeces and long-fibre components
 - Wastewater

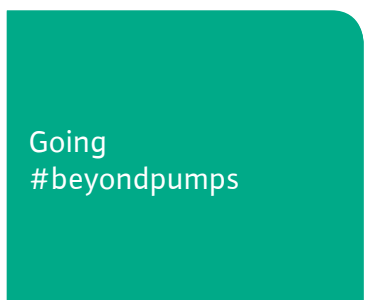

Wilo-RexaNorm RE

Sewage pump with standard motor, connected via coupling, fully mounted on baseplate, for stationary dry well installation

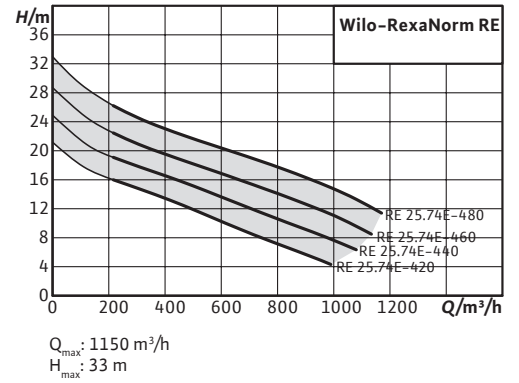
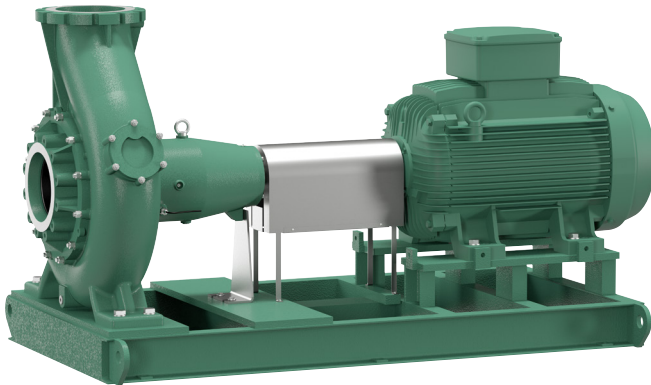

14



Special features/product advantages

- Easy impeller replacement due to “back pull-out” design and spacer coupling as standard. This makes it possible to uninstall the impeller without dismantling the hydraulics from the pipeline and the motor from the baseplate.
- Shut „Back pull out“ unit: Dismantling without draining the oil in the sealing chamber

Application

- Pumping of
- Untreated sewage with faeces and long-fibre components
 - Sewage containing faeces
 - Pre-cleaned sewage without faeces and long-fibre components
 - Process water
 - Wastewater



Going #beyondpumps

Wilo-EMU TR 14... – TR 28...

Compact directly driven submersible mixer

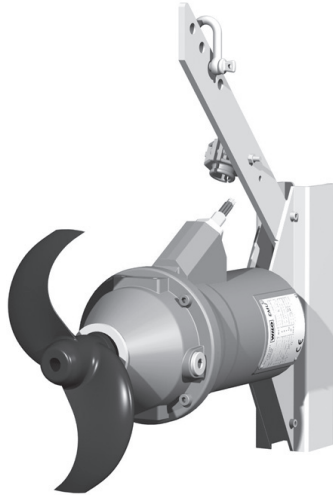

15



Special features/product advantages

- Works reliably
- Clogging-free operation with backward-curved incoming flow edge and self-cleaning helix hub
- Reduced costs
- Quick and simple to install as a ground, wall or pipe fixation. Even in the smallest of space requirements

Application

- Swirling of deposits and solids in stormwater retention tanks and pump sump
- Destruction of floating sludge layers

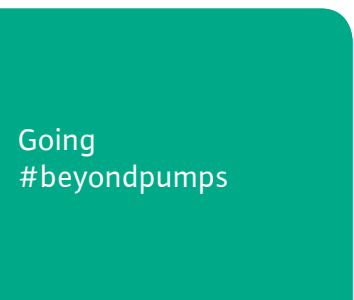

Wilo-EMU TR 22... – TR 40...

Compact directly driven submersible mixer

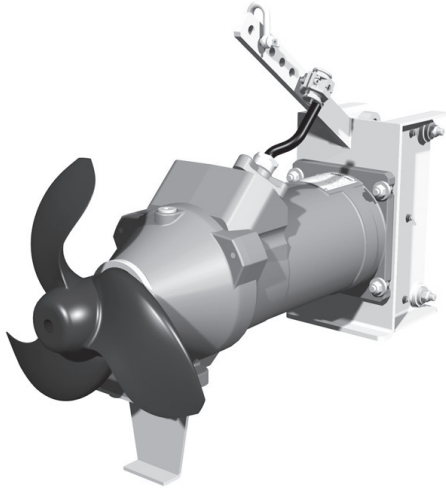

16



Special features/product advantages

- Works reliably
- Clogging-free operation with backward-curved incoming flow edge and self-cleaning helix hub
- Reduced costs
- Quick and simple to install as a ground, wall or pipe fixation. Even in the smallest of space requirements

Application

- Swirling of deposits and solids in stormwater retention tanks and pump sump
- Destruction of floating sludge layers

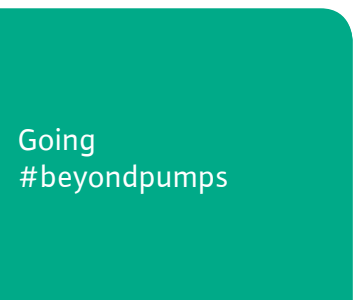

Wilo-EMU TR 50-2... – TR 120-1...

Submersible mixer with single-stage planetary gear



17



Special features/product advantages

- Secure your processes
- The planetary gear has large dimensions so that the mixing forces are absorbed efficiently
- Efficient energy usage
- The innovative blade geometry ensures the best possible specific thrust coefficient. At the same time, this reduces your energy and operating costs
- Reliable operation
- Clogging-free operation with backward-curved incoming flow edge

Application

- Generation of flow
- Suspension of solid matter
- Homogenization
- Prevention of floating sludge layers



Going
#beyondpumps

Wilo-EMU TR 212... – TR(E) 326...

Slow-running submersible mixer with two-stage planetary gear reduction



18



Special features/product advantages

- Efficient energy usage
- The innovative blade geometry and energy-efficient IE3 motors ensure the best possible specific thrust coefficient. At the same time, this reduces your energy and operating costs
- Consistently reliable
- The low-wearing GFK/PA6 propeller is durable and scores with its self-cleaning effect
- Smooth running thanks to the balanced propeller load, even in high thrust ranges and when incoming flow conditions are unfavourable

Application

- Energetically optimized mixing and circulation of activated sludges
- Generation of flow rates in circulation channels

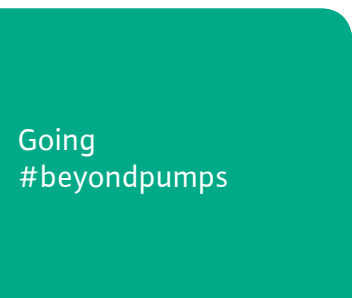

Wilo-EMU RZP 20, RZP 80-2

Recirculation pump, directly driven or with single-stage planetary gear

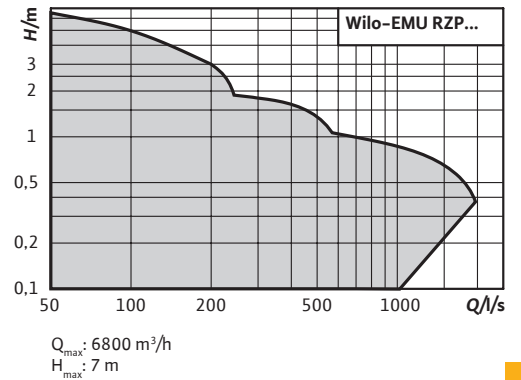
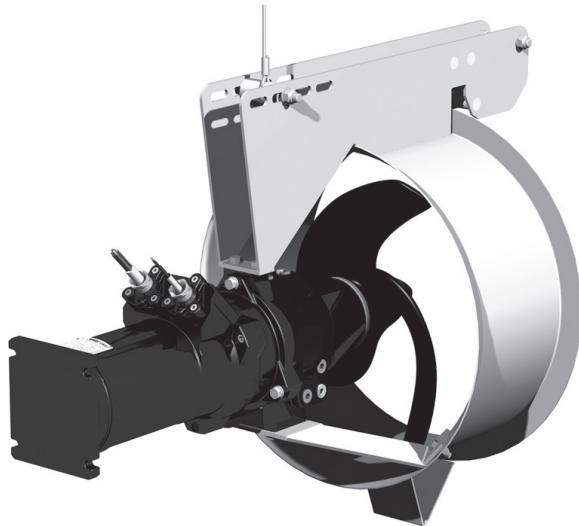

Special features/product advantages

- Can be installed vertically or in the pipe (inline)
- Low clogging due to self cleaning propeller in stainless steel or PUR

Application

- Pumping of
- High sewage flow rates via low delivery heads, e.g. between balancing, nitrification and denitrification basins
 - Process, raw, pure and cooling water, e.g. in paint finishing systems or for drinking water treatment

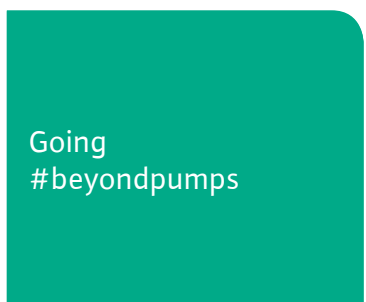

Wilo-EMU KPR

Axial pump submersible without cooling system for continuous duty in pipe chambers in the stationary wet well installation

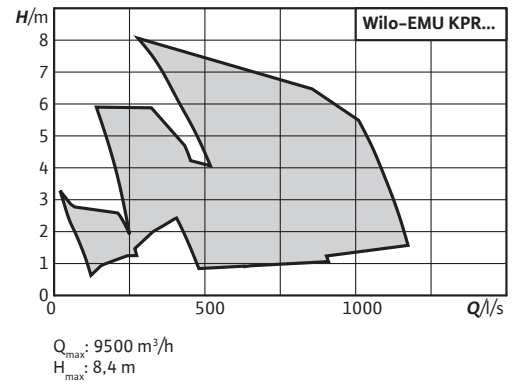

20



Special features/product advantages

- Can be directly installed in the discharge pipe
- Adjustable angle of the propeller blades
- Process reliability thanks to comprehensive monitoring devices
- Low vibration and long lifetimes thanks to high-quality components
- Customisable, precisely tailored to your requirements

Application

- Pumping of
- Pre-cleaned sewage without faeces and long-fibre components
 - Process water
 - Wastewater
 - Process water



Going #beyondpumps



Wilo-Select 4 online

The pump consultant

The new online application for pump dimensioning – flexible, convenient, efficient and powerful. Experience pump dimensioning in 4D with our new Wilo-Select 4 online: it makes your designing easier, faster and safer than ever before. Over the internet you have always flexible access to latest product data – where ever and whenever you want.

“Product recommendation in only 4 steps, that’s what I call Pioneering for You.”

Wilo-Select 4 online, the pump consultant:

- Easy handling
- Reliable product configuration with hydraulic calculations
- Comparison of amortisation times, operating costs and life cycle costs at a glance
- Optimum support for designing and customer consultation



Wilo Services.

Our full-service package for you as partners.

With Wilo as your partner, you can not only be sure of choosing high-quality product solutions but also of benefiting from a comprehensive, worry-free package of well thought out services. This means that we support you personally in every project phase, from design and configuration right through commissioning and maintenance. In our seminars we tell you about the very latest technologies and trends. And when it comes to attractive conditions for your projects, we also have just the right package to offer.

In short, Wilo is always by your side. In person and on the spot. With local services in over 60 countries and more than 1,200 Wilo engineers worldwide.

We make the design and selection process simple for you.

We do not want you to select any solution, but the one that exactly meets your requirements. As a result, we work through your requirements with you before the purchase and, based on this, we prepare the individual product solution that is most economical for you.

Pre-sales services for your tailor-made choice:

- Local support
- Design support
- Product selection
- Selection programmes
- Digital flow simulations
- Flow calculation
- Pipe calculation
- Installation drawings
- Documentation



“Services that provide comprehensive and reliable support.

That’s what we call Pioneering for You.”

For more information, go to
www.wilo.com/en/watermanagement



You cannot go wrong with Wilo.

When you have made your choice, we provide you with thorough advice on your investment. What is more, we do not just deliver your solution, we continue to support you – from certification right through to commissioning. For example, qualified plant engineers with years of experience will carry out an extensive test and training phase with our pumps.

Sales services that really work for you.

- Certification
- Acceptance testing at the plant
- Commissioning
- Start-up

→ Wilo-Financial Services.

We help you with the financial implementation of your projects, and gladly create a quotation specially tailored for your investment.

→ Try & Buy

Try & Buy lets you play safe with your investments. Choose a no-risk trial for up to six months to convince yourself of the quality of Wilo's products.

Try & Buy is only available in participating Wilo subsidiaries. Please contact your Wilo sales representative for local options of Try & Buy.



We are there for you. Even after the purchase.

Our tailor-made service solutions cover the entire lifecycle of your Wilo products – including what comes after your purchase. That is why we have professional service engineers available for you locally and globally so that we can supply spare parts quickly and reliably at any time, and why we provide targeted training courses among other things to enhance your expertise. And we continually strive to improve our services.

After-sales services with real added value for you!

- Customised, reliable maintenance concepts
- Rapid repair service
- Fast spare parts solutions
- Efficiency check
- Specific training courses

→ WiloCare

Our service offer for guaranteed operational reliability and cost certainty. Monthly reports keep you up to date on how your system is doing: system status, energy consumption, possible optimisations and pending maintenance intervals. Wilo can offer you individually tailored services in various packages at a fixed monthly price. These allow you to check how reliable your processes are at any time – both in terms of technology and costs.





Subject to change. In appliance of our
General Terms of Delivery and Service
(see www.wilo.com)

2189378/500/1611/EN/DDD

WILO SE
Werk Hof
Heimgartenstraße 1-3
D-95030 Hof
T +49 9281 974-550
F +49 9281 974-551
wilo@wilo.com
www.wilo.de

WILO SE
Nortkirchenstraße 100
44263 Dortmund
Germany
T +49 231 4102-0
F +49 231 4102-7363
wilo@wilo.com
www.wilo.com